



Wykamol Group

Knowsley Road Industrial Estate
 Haslingden
 Rossendale
 Lancashire BB4 4RX
 Tel: 01706 831223 Fax: 01706 214998
 e-mail: sales@lectros.com
 website: www.wykamol.com

(21.9)	Ln6
--------	-----

**Agrément
 Certificate
 No 05/4261**

Designated by Government
 to issue
 European Technical
 Approvals

WYKAMOL MEMBRANE SYSTEMS

Soutien étanche
 Wasserdichte Stütze

Product



• THIS CERTIFICATE RELATES TO WYKAMOL MEMBRANE SYSTEMS, MOULDED HDPE MEMBRANES AND FIXING / SEALING MATERIALS DESCRIBED IN THE ACCOMPANYING DETAIL SHEETS AND USED FOR DAMP-PROOFING IN NEW OR EXISTING BUILDINGS.

These Front Sheets must be read in conjunction with the relevant accompanying Detail Sheets, which provide information specific to membrane systems.

Regulations — Detail Sheet 1

1 The Building Regulations 2000 (as amended) (England and Wales)

 The Secretary of State has agreed with the British Board of Agrément the aspects of performance to be used by the BBA in assessing the compliance of waterproofing-tanking (walls) with the Building Regulations. In the opinion of the BBA, the use of Wykamol Membrane Systems in new constructions, if used in accordance with the provisions of this Certificate, will meet or contribute to meeting the relevant requirements. In the opinion of the BBA, the use of Wykamol Membrane Systems in an existing building is not subject to these Regulations, but action to satisfy Requirement C2 and Regulation 7 may be necessary for a 'Material change of use' as defined in Regulation 5(a).

Requirement: C2(a)(b)	Resistance to moisture
Comment:	The systems adequately resist the passage of moisture. See the tinted area of the <i>Resistance to water and water vapour</i> section of the accompanying Detail Sheets.
Requirement: Regulation 7	Materials and workmanship
Comment:	The systems are acceptable. See the tinted area of the <i>Durability</i> section of the accompanying Detail sheets.

Electronic Copy

2 The Building (Scotland) Regulations 2004



In the opinion of the BBA, the use of Wykamol Membrane Systems in new constructions, if used in accordance with the provisions of the Certificate, will satisfy or contribute to satisfying the various Regulations and related Mandatory Standards as listed below. In the opinion of the BBA, the use of Wykamol Membrane Systems in an existing building is not controlled by these Regulations, but action to satisfy the Regulations and related Mandatory Standards below may be necessary for a 'Conversion' as defined in Regulation 4 of these Regulations.

Regulation:	8	Fitness and durability of materials and workmanship
Regulation:	8(1)	Fitness and durability of materials and workmanship
Comment:		The systems can contribute to a construction satisfying this Regulation. See the tinted area of the <i>Durability</i> section and the <i>Installation</i> part of the accompanying Detail Sheets.
Regulation:	9	Building standards — construction
Standard:	3.3	Flooding and ground water
Standard:	3.4	Moisture from the ground
Standard:	3.6(a)	Surface water drainage
Standard:	3.10	Precipitation
Comment:		The systems adequately resist the passage of moisture and can contribute to satisfying these Standards with reference to clauses 3.3.1 ⁽¹⁾⁽²⁾ , 3.4.1 ⁽¹⁾⁽²⁾ , 3.4.2 ⁽¹⁾⁽²⁾ , 3.4.6 ⁽¹⁾⁽²⁾ , 3.6.1 ⁽¹⁾⁽²⁾ , 3.6.3 ⁽¹⁾⁽²⁾ and 3.10.1 ⁽¹⁾⁽²⁾ . See the tinted area of the <i>Resistance to water and water vapour</i> section of the accompanying Detail Sheets.
Regulation:	12	Building standards — conversions
Comment:		All comments given for these systems under Regulation 9, also apply to this Regulation with reference to clause 0.12.1 ⁽¹⁾⁽²⁾ and Schedule 6 ⁽¹⁾⁽²⁾ . (1) Technical Handbook (Domestic). (2) Technical Handbook (Non-Domestic).

3 The Building Regulations (Northern Ireland) 2000



In the opinion of the BBA, the use of Wykamol Membrane Systems in new constructions, if used in accordance with the provisions of this Certificate, will satisfy or contribute to satisfying the various Building Regulations as listed below. In the opinion of the BBA, the use of Wykamol Membrane Systems in an existing building is not controlled by these Regulations, but action to satisfy Regulations B2 and C4 may be necessary for a 'Material change of use' under Regulation A9.

Regulation:	B2	Fitness of materials and workmanship
Comment:		The systems are acceptable. See the tinted area of the <i>Durability</i> section of the accompanying Detail Sheets.
Regulation:	C4	Resistance to ground moisture and weather
Comment:		The systems adequately resist the passage of moisture. See the tinted area of the <i>Resistance to water and water vapour</i> section of the accompanying Detail Sheets.

4 Construction (Design and Management) Regulations 1994 (as amended) Construction (Design and Management) Regulations (Northern Ireland) 1995 (as amended)

Information in this Certificate may assist the client, planning supervisor, designer and contractors to address their obligations under these Regulations.

See sections: 1 *Description* (1.2) and 10 *Installation* (10.1) of the accompanying Detail Sheets.

Technical Specification

5 Manufacture and quality control

5.1 Wykamol Membrane Systems are formed in a continuous process in which high-density polyethylene (HDPE) or polypropylene (PP) is extruded into sheets and the domes impression formed.

5.2 Quality control is exercised over raw materials, during the production process and on the final product.

6 Delivery and site handling

6.1 The membranes are delivered to site in rolls secured with outer wrapping bearing the product and manufacturer's name and the BBA logo bearing the number of this Certificate.

6.2 Rolls should be stored on end, under cover and protected from sharp objects, sunlight and high temperatures.

Conditions of Certification

7 Conditions

7.1 This Certificate:

- (a) relates only to the product that is named, described, installed, used and maintained as set out in this Certificate;
- (b) is granted only to the company, firm or person identified on the front cover — no other company, firm or person may hold or claim any entitlement to this Certificate;
- (c) is valid only within the UK;
- (d) has to be read, considered and used as a whole document — it may be misleading and will be incomplete to be selective;
- (e) is copyright of the BBA;
- (f) is subject to English law.

7.2 References in this Certificate to any Act of Parliament, Regulation made thereunder, Directive or Regulation of the European Union, Statutory Instrument, Code of Practice, British Standard,

manufacturers' instructions or similar publication, are references to such publication in the form in which it was current at the date of this Certificate.

7.3 This Certificate will remain valid for an unlimited period provided that the product and the manufacture and / or fabrication including all related and relevant processes thereof:

- (a) are maintained at or above the levels which have been assessed and found to be satisfactory by the BBA;
- (b) continue to be checked as and when deemed appropriate by the BBA under arrangements that it will determine; and
- (c) are reviewed by the BBA as and when it considers appropriate.

7.4 In granting this Certificate, the BBA is not responsible for:

- (a) the presence or absence of any patent, intellectual property or similar rights subsisting in the product or any other product;
- (b) the right of the Certificate holder to market, supply, install or maintain the product; and
- (c) the actual works in which the product is installed, used and maintained, including the nature, design, methods and workmanship of such works.

7.5 Any recommendations relating to the use or installation of this product which are contained or referred to in this Certificate are the minimum standards required to be met when the product is used. They do not purport in any way to restate the requirements of the Health & Safety at Work etc Act 1974, or of any other statutory, common law or other duty which may exist at the date of this Certificate or in the future; nor is conformity with such recommendations to be taken as satisfying the requirements of the 1974 Act or of any present or future statutory, common law or other duty of care. In granting this Certificate, the BBA does not accept responsibility to any person or body for any loss or damage, including personal injury, arising as a direct or indirect result of the installation and use of this product.



In the opinion of the British Board of Agrément, Wykamol Membrane Systems are fit for their intended use provided they are installed, used and maintained as set out in this Certificate. Certificate No 05/4261 is accordingly awarded to the Wykamol Group.

On behalf of the British Board of Agrément

Date of issue: 31st March 2006

A handwritten signature in black ink, appearing to read 'G. A. Cooper', is written over a white background.

Chief Executive

Product

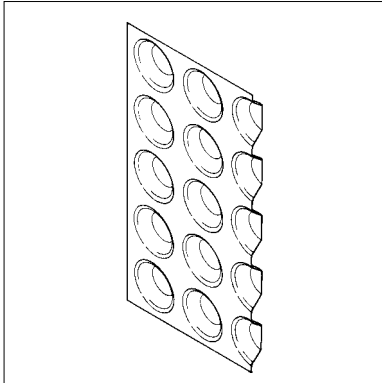

• THIS DETAIL SHEET RELATES TO WYKAMOL CM8, A MOULDED HDPE MEMBRANE AND FIXING / SEALING MATERIALS.

• The membrane is used on walls, floors and ceilings above or below ground, in new construction or in existing buildings over a contaminated or damp background, to support a dry lining or flooring.

• The membrane may also be used in conjunction with Wykamol CM20 and Wykamol CM Plaster in sealed systems

• The system should be installed by competent contractors

This Detail Sheet must be read in conjunction with the Front Sheets which give the system's position regarding the Building Regulations, general information relating to the product, and the Conditions of Certification.

Technical Specification

1 Description

1.1 Wykamol CM8 is a translucent HDPE membrane, moulded to form raised domes at 25 mm centres (see Figure 1).

1.2 Characteristics of the membrane are:

thickness (mm)	0.5
dome height (mm)	6.5
weight per unit area (kgm ²)	0.48
air gap volume (lm ²)	4.0

1.3 It is supplied in the dimensions given in Table 1.

Table 1 Wykamol CM8 dimensions and weights

Roll dimensions (m)	Weight (kg)
2.07 x 20 ⁽¹⁾	19.87
2.47 x 20 ⁽¹⁾	23.70

(1) Includes a 70 mm dome-free area for overlapping sheets

1.4 Ancillary items used with the membranes include:

- Wykamol Brick Plug — a plastic, pre-drilled plug for fixing membrane to brick and stone (see Figure 2)
- Wykamol Tape — butyl rubber tape for sealing joints in the membrane
- Wykamol Rope — butyl rubber beading for sealing joints in the membrane, sealing the membrane around pipes and openings and to form a gasket between the brick plug and membrane
- Wykamol Mastic — acrylic rubber sealant for sealing the membrane around pipes and openings
- Wykamol Corner Detail — butyl tape, 150 mm wide, backed with aluminium foil for sealing junctions between walls and floors, and for sealing joints at corners
- Wykamol Fibre Tape — butyl rubber tape, at least 100 mm wide, backed with non-woven polypropylene for sealing joints in the membrane.

Figure 1 Wykamol CM8

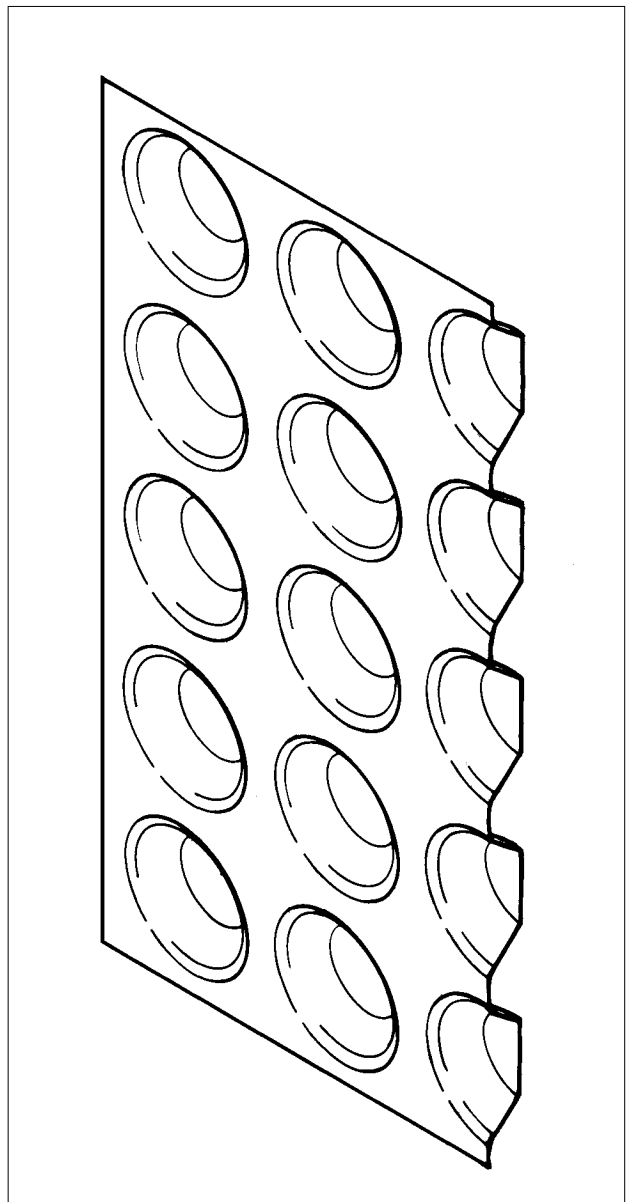
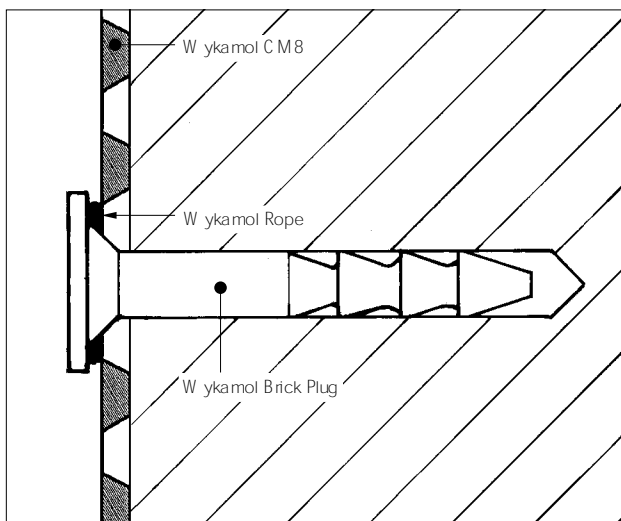

Figure 2 W ykamol Brick Plug fixing detail



Design Data

2 General

2.1 W ykamol C M8 is satisfactory as a support for a dry lining, screed or flooring, over internal faces of walls and floors of all types of existing construction, in the following situations

- damp walls and floors in underground situations subject to high groundwater levels and perennial moisture
- on vaulted ceilings of archways or cellars subject to dripping water
- with a remedial dpc system where the walls and floors have a high salt content, and/ or it is necessary to complete the installation immediately without allowing a period for initial drying
- over walls and floors which have a friable or painted surface, are contaminated with oil or mould, or have a high salt content
- as a waterproofing or 'tanking' in areas subject to vibration

2.2 Depending on the application required and the site conditions the membrane may be used as

- an underfloor damp-proof membrane
- a dry-lining for walls ventilated into the room via aeration slots at the top and bottom of the wall
- a completely sealed system covering floor, wall and ceiling used, where appropriate, in conjunction with other W ykamol membranes covered by this Certificate, with provision made for disposing of water build-up behind the membrane via a sump and pump.

2.3 The system is satisfactory for use in Type C (drained protection) structural concrete constructions in accordance with BS 8102 : 1990, Clause 3.2.4.

2.4 Under normal operating conditions the membrane is not affected by underfloor heating.

3 Resistance to water and water vapour

 3.1 The membrane is water resistant and has a high resistance to water vapour. Consequently the measures described in the *Installation* part of this Detail Sheet must be followed to ensure that the membrane acts as a drainage layer and that there is no excessive build-up of water behind the system.

3.2 All joints and fixings must be sealed with W ykamol sealing products and drainage channels and gullies or

sumps and pumps should be installed as necessary to disperse excess or standing water.

3.3 Floors should have a drainage outlet point. There should be a fall towards the outlet point or a drainage channel made around the perimeter of the floor, to ensure water can flow to the outlet.

3.4 Where insulation is laid over the membrane, a vapour control layer should be used unless a condensation risk assessment in accordance with BS 5250 : 2002 shows it not to be necessary. However, due to the high vapour resistance of the membrane, it is essential to ensure that the vapour control layer is continuous and joints are carefully and fully sealed.

3.5 Care should be taken to ensure that adequate room ventilation is provided to limit the risk of interstitial and surface condensation.

4 Resistance to salt transfer

The system provides an effective barrier to the transmission of salts or other contaminants from the substrate.

5 Resistance to puncture, impact and loading

5.1 The membrane has a high resistance to puncture and will not be damaged by normal foot traffic during installation or while laying concrete or screeding to BS 8204-1 : 2003.

5.2 The membrane can support the long-term imposed loadings defined in BS 6399-1 : 1996, Table 1, categories A, C1 and C2, and situations with similar loadings in category B, without undue deformation.

6 Wall-mounted fittings

Wall-mounted fittings (apart from lightweight items such as framed pictures) should be fixed where possible into battens whose position and number of support fixings into the loadbearing structure are predetermined. Only in exceptional circumstances should fittings be fixed through the membrane and lining board to the loadbearing structure behind, using proprietary fixings. Holes made in the membrane must be filled with a flexible sealant such as W ykamol Mastic, Rope or Tape.

7 Durability

 7.1 Under normal conditions of use the system will provide an effective barrier to the transmission of salts, liquid water and water vapour for the life of the structure in which it is incorporated.

7.2 Regular maintenance of all gullies, sumps and pumps must be conducted to ensure that a build-up of water does not occur behind the membrane.

Installation

8 Survey in damp conditions

8.1 Where conditions are damp, a full survey is necessary by a specialist surveyor to diagnose the cause and to establish if treatment is required.

8.2 If rising damp is found, a remedial treatment is conducted in accordance with the relevant Agreement Certificate, BS 6576 : 2005 and the BW PDA Code of Practice C0 P3 : 1997.

8.3 Appropriate remedial measures are taken to rectify major causes of damp conditions or water ingress and to repair structural defects.

9 Surface preparation

9.1 When used in new constructions the concrete base must be laid in accordance with BS 8204-1 : 2003. If

a board covering is to be laid directly on the membrane, the concrete base must have a surface regularity of at least SR 2⁽¹⁾, as described in BS 8204-1 : 2003.

(1) Maximum permissible departure of 5 mm from the underside of a 2 m straight edge, resting in contact with the floor.

9.2 Any unsound plaster, render or screed should be removed to expose the substrate which is then cleaned with a stiff brush to remove loose material, laitance, salt residue, mould or adhesive. If mould is present the substrate should be treated with a fungicidal wash. The Certificate holder can advise on suitable materials and procedures to be used.

9.3 Uneven substrates should be dubbed out with a cement and (1:4) render or screed, to the tolerance described in section 9.1. They should be allowed to set before the membrane is fixed.

10 Walls and ceilings

General

10.1 Power cables, points and light switches should preferably be remounted in front of the membrane.

10.2 The membrane should always be used with the flanged edge positioned in front of, and overlapping, the previously installed membrane width. Joints with the flanged edge are sealed using W ykamol Tape, while stud-to-stud joints (without the flanged edge) are sealed by overlapping the membrane by a minimum of 200 mm and using W ykamol Rope.

10.3 Fixings are made through the domes into holes drilled through the membrane. W ykamol Brick Plugs to which W ykamol Rope has been applied around the rim are inserted into the holes and tapped flush with the membrane. The W ykamol Rope forms a sealing gasket between the plug and membrane.

10.4 Spacing between fixings will depend on the application and the nature of the substrate, but should be kept to a maximum of 600 mm.

10.5 Preservative-treated timber battens of minimum dimensions 25 mm by 38 mm are fixed into the plug's fixing hole using suitable screws with a maximum screwing-in depth of 25 mm plus the batten depth. If required, W ykamol Mastic is injected into the fixing holes to reduce the risk of water penetration.

Ceilings

10.6 Ceilings to be covered should always have a fall, as per vaulted cellar constructions, to ensure water does not build up against the membrane or a joint. In addition to the requirements given in section 10.8, on ceilings the vertical drop between the ends of the two membrane sheets for horizontal overlaps should be a minimum of 100 mm.

10.7 The membrane should be adequately supported, to avoid the possibility of ponding.

10.8 At the end walls of vaulted constructions the membrane must be turned down onto the end wall by a minimum 300 mm (ie 12 domes). The membrane is mitred as necessary to fit the curve of the ceiling, and the joint sealed with W ykamol Tape or Rope. The wall membrane should be cut to fit the curve of the ceiling, fixed in front of the ceiling membrane, and the gap sealed with W ykamol Tape, Rope or Mastic.

Walls

10.9 Installation of the membrane is commenced at the top of the construction. The membrane may require initial fixing on a ceiling or along the upper edge of a wall, prior to final fixings along batten runs. For joints where the flanged edge is not used, the two membrane sheets

are overlapped by a minimum of 200 mm, and for horizontal joints the lower sheet is always positioned in front of the upper sheet.

10.10 The membrane is installed over windows and then cut away to expose them. For doors and other obstructions, the membrane is installed up to the perimeter. In both cases the gaps are sealed with W ykamol Fibre Tape or Corner Detail.

10.11 In cases where a 'sealed' system is not being installed, the build-up of water vapour behind the membrane is controlled by venting into the room. To facilitate this, the membrane is installed with a 10 mm gap at the top, and a 20 mm gap at the bottom of the wall. Spacers measuring 3 mm by 200 mm are then fixed at 600 mm centres behind the skirting board and ceiling coving to ensure a ventilation gap (see Figure 3). Alternatively, a proprietary ventilated skirting board or ceiling coving may be used.

Figure 3 Wall detail with dry lining (ventilated system)

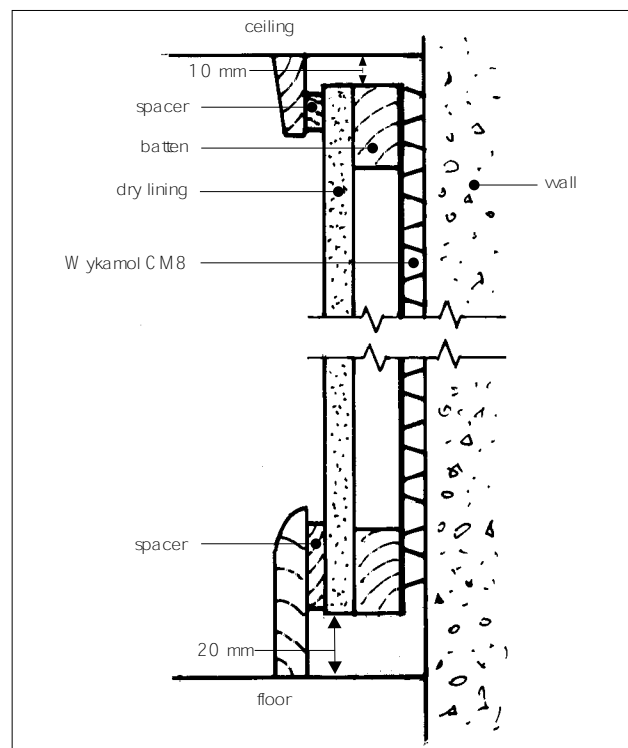

11 Floors

11.1 The membrane is rolled out 'domes down' over the floor, and consecutive membrane widths are laid so that the flanged edge overlaps the previous sheet by two domes. Joints are sealed using W ykamol Tape. Other joints are oversealed using W ykamol Fibre Tape.

11.2 The membrane is cut within 5 mm to 10 mm of any pipes and services in the floor, and the gap filled with W ykamol Rope. A patch of membrane is overlaid and sealed to the service with W ykamol Rope, and its circumference sealed with W ykamol Corner Detail or Fibre Tape.

11.3 Fixings must not be applied through the floor membrane.

11.4 Where appropriate, at wall/ floor junctions and corners of the installation, the membrane should be cut flush and the gap between the wall and floor membranes sealed with W ykamol Corner Detail. Alternatively, where a wall membrane is not being installed the floor membrane may be turned up by 100 mm at the wall and cut flush with the top of the finished floor.

11.5 At corners, where membranes are not installed continuously from one surface to the next, they should be finished at the corner on each surface, and sealed together using W ykamol Corner Detail.

12 Dry lining

12.1 Gypsum plasterboard to BS 1230-1 : 1985, or similar dry lining boards covered by a current Agreement Certificate, are fixed to the battens with galvanized screws or nails positioned a minimum of 12 mm from the edge of the board. Care should be taken to ensure that penetration of the plasterboard screws or nails is less than batten depth to avoid puncturing the membrane.

12.2 Alternatively, linings can be free-standing framework, blockwork or similar. Where necessary these should be tied back by fixing into the W ykamol Brick Plug's fixing hole. W ykamol Mastic may be injected into the fixing hole to reduce the risk of water penetration.

13 Floor membrane coverings

13.1 If required, expanded polystyrene insulation boards minimum density 30 kgm³, are laid over the membrane.

13.2 Suitable tongue-and-groove flooring board panels should be selected in accordance with BS EN 12871 : 2001, and loose-laid over the membrane to within 10 mm of the walls. The panels are staggered and the joints sealed with either a thermoplastic wood adhesive to BS EN 204 : 2001, or a PVA adhesive to BS 4071 : 1966.

13.3 Alternatively, the membrane is covered by concrete or screed 50 mm thick in accordance with BS 8204-1 : 2003. Care should be taken to ensure the membrane is not displaced when placing the concrete or screed. The concrete screed should be reinforced to inhibit shrinkage cracks.

13.4 Proprietary screeds may also be considered which can generally be laid at thicknesses less than 50 mm, but use of these products with the membrane has not been assessed by the BBA.

14 Finishing

After the system has been installed and the walls dry-lined, permanent decorations such as vinyl papers or oil paints may be applied. Temporary permeable decorations (necessary with traditional, cement-based waterproofers) are not necessary for use with this system.

Technical Investigations

The following is a summary of the technical investigations carried out on W ykamol CM8.

15 Tests

15.1 Tests were carried out to determine:

- thickness
- resistance to short-term compression
- resistance to long-term loading
- nail-tear resistance
- effectiveness of sealing rope/ membrane bond.

15.2 Independent test reports were examined and assessed, relating to:

- melt flow index
- tensile strength and elongation at break

16 Investigations

16.1 The manufacturing process was examined, and details obtained of the raw material specifications and quality control procedures.

16.2 An assessment was made of the scope of use and durability of the system in relation to the generic properties of the membrane.

Bibliography

BS 1230-1 : 1985 *Gypsum plasterboard — Specification for plasterboard excluding materials submitted to secondary operations*

BS 4071 : 1966 *Specification for polyvinyl acetate (PVA) emulsion adhesives for wood*

BS 5250 : 2002 *Code of practice for control of condensation in buildings*

BS 6399-1 : 1996 *Loading for buildings — Code of practice for dead and imposed loads*

BS 6576 : 2005 *Code of practice for installation of chemical damp-proof courses*

BS 8102 : 1990 *Code of practice for protection of structures against water from the ground*

BS 8204-1 : 2003 *Screeds, bases and in-situ floorings — Concrete bases and cement-sand levelling screeds to receive floorings — Code of practice*

BS EN 204 : 2001 *Classification of thermoplastic wood adhesives for non-structural applications*

BS EN 12871 : 2001 *Wood-based panels — Performance specifications and requirements for load bearing boards for use in floors, walls and roofs*

BW PDA Code of Practice C O P3 : 1997 *Code of Practice for Installation of Chemical Damp-proof Courses*



On behalf of the British Board of Agreement

Date of issue: 31st March 2006

A handwritten signature in black ink, appearing to read 'G. A. Cooper'.

Chief Executive

Product

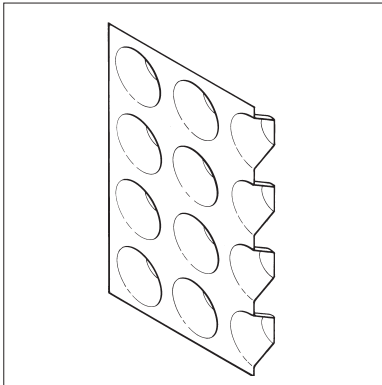

• THIS DETAIL SHEET RELATES TO WYKAMOL CM20, A MOULDED HDPE MEMBRANE AND FIXING/SEALING MATERIALS.

- The membrane is used on walls and floors above and below ground that require a large air gap for a high drainage volume to support dry lining or flooring.
- The membrane may also be used in conjunction with Wykamol CM8 and Wykamol CM Plaster in sealed systems.
- The system should be installed by competent contractors.

This Detail Sheet must be read in conjunction with the Front Sheets, which give the system's position regarding the Building Regulations, general information relating to the product, and the Conditions of Certification.

Technical Specification

1 Description

1.1 Wykamol CM20 is a black, high-density polyethylene (HDPE) membrane, moulded to form raised domes at 50 mm centres (see Figure 1).

1.2 Wykamol CM20 is available in roll form, and has characteristics of:

thickness (mm)	1.0
dome height (mm)	20.0
weight per unit area (kgm ⁻²)	0.95
roll size (m)	2.07 x 20 (with flange) 2.0 x 20 (without flange)
weight of roll (kg)	38 approx
air gap volume (lm ⁻²)	14

1.3 Ancillary items used with the membranes are:

- Wykamol Brick Plug — plastic, pre-drilled plug for fixing membrane to brick and stone (see Figure 2)
- Wykamol Tape — butyl rubber tape for sealing joints in the membrane
- Wykamol Rope — butyl rubber beading for sealing joints in the membrane, sealing the membrane around pipes and openings and to form a gasket between the brick plug and membrane
- Wykamol Mastic — acrylic sealant for sealing the membrane around pipes and membrane
- Wykamol Corner Detail — butyl tape, 150 mm wide, backed with aluminium foil for sealing junctions between walls and floors, and for sealing joints at corners
- Wykamol Fibre Tape — butyl rubber tape, at least 100 mm wide, backed with non-woven polypropylene for sealing joints in the membrane.

Figure 1 Wykamol CM20

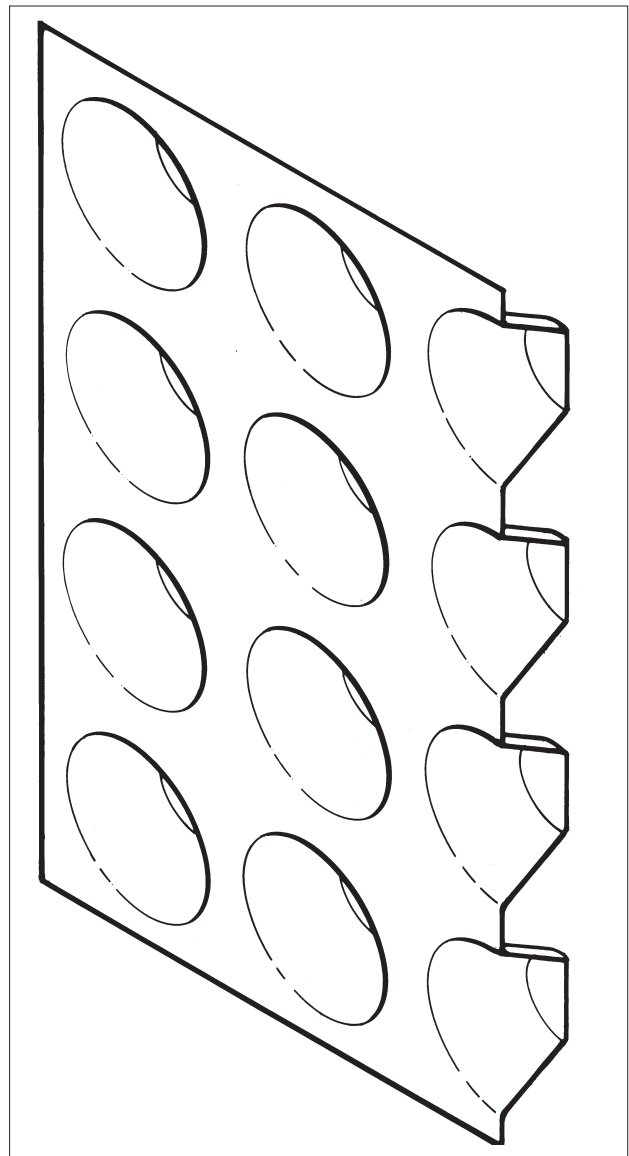
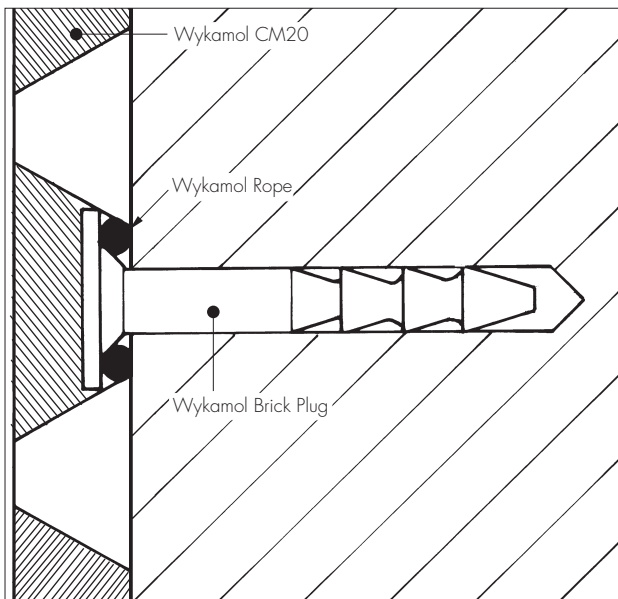

Figure 2 Wykamol Brick Plug fixing detail



Design Data

2 General

2.1 Wykamol CM20 is satisfactory as a support for a dry lining, screed or flooring, over internal faces of walls and floors of all types of existing construction, in the following situations:

- damp walls and floors in underground situations subject to high groundwater levels, and perennial moisture
- with a remedial dpc system where the walls and floors have a high salt content, and/or it is necessary to complete the installation immediately without allowing a period for initial drying
- over walls and floors which have a friable or painted surface, are contaminated with oil or mould, or have a high salt content
- as a waterproofing or 'tanking' in areas subject to vibration.

2.2 Depending on the application required and the site conditions, the membrane may be used as:

- an underfloor damp-proof membrane
- a dry-lining for walls, ventilated into the room via aeration slots at the top and bottom of the wall
- a completely sealed system covering floor, wall and ceiling used, where appropriate, in conjunction with other Wykamol membranes covered by this Certificate, with provision made for disposing of water build-up behind the membrane via a sump and pump.

2.3 The system is satisfactory for use in Type C (drained protection) structural concrete constructions in accordance with BS 8102 : 1990, Clause 3.2.4.

2.4 Under normal operating conditions the membrane is not affected by underfloor heating.

3 Resistance to water and water vapour

3.1 The membrane is water resistant and has a high resistance to water vapour. Consequently the measures described in the *Installation* part of this Detail Sheet must be followed to ensure that the membrane acts as a drainage layer and that there is no excessive build-up of water behind the system.

3.2 All joints and fixings must be sealed with Wykamol sealing products, and drainage channels and gullies, or sumps and pumps should be installed as necessary to disperse excess or standing water.

3.3 Floors should have a drainage outlet point. There should be a fall towards the outlet point or a drainage channel made around the perimeter of the floor, to ensure water can flow to the outlet.

3.4 Where insulation is laid over the membrane, a vapour control layer should be used unless a condensation risk assessment in accordance with BS 5250 : 2002 shows it not to be necessary. However, due to the high vapour resistance of the membrane, it is essential to ensure that the vapour control layer is continuous and joints are carefully and fully sealed.

3.5 Care should be taken to ensure that adequate room ventilation is provided to limit the risk of interstitial and surface condensation.

4 Resistance to salt transfer

The system provides an effective barrier to the transmission of salts or other contaminants from the substrate.

5 Resistance to puncture, impact and loading

5.1 The membrane has a high resistance to puncture and will not be damaged by normal foot traffic during installation or while laying concrete or screeding to BS 8204-1 : 2003.

5.2 The membrane can support the long-term imposed loadings defined in BS 6399-1 : 1996, Table 1, categories A, C1 and C2, and situations with similar loadings in category B, without undue deformation.

6 Wall-mounted fittings

Wall-mounted fittings (apart from lightweight items such as framed pictures) should be fixed where possible into battens, whose position and number of support fixings into the loadbearing structure are predetermined. Only in exceptional circumstances should fittings be fixed through the membrane and lining board to the loadbearing structure behind, using proprietary fixings. Holes made in the membrane must be filled with a flexible sealant, such as Wykamol Mastic, Rope or Tape.

7 Durability

7.1 Under normal conditions of use the system will provide an effective barrier to the transmission of salts, liquid water and water vapour for the life of the structure in which it is incorporated.

7.2 Regular maintenance of all gullies, sumps and pumps must be conducted to ensure that a build-up of water does not occur behind the membrane.

Installation

8 Survey in damp conditions

8.1 Where conditions are damp, a full survey is necessary by a specialist surveyor to diagnose the cause and to establish if treatment is required.

8.2 If rising damp is found, a remedial treatment is conducted in accordance with the relevant Agrément Certificate, BS 6576 : 2005 and the BWPDA Code of Practice COP3 : 1997.

8.3 Appropriate remedial measures are taken to rectify major causes of damp conditions or water ingress, and to repair structural defects.

9 Surface preparation

9.1 When used in new constructions the concrete base must be laid in accordance with BS 8204-1 : 2003. If a board covering is to be laid directly on the membrane, the concrete base must have a surface regularity of at least SR 2⁽¹⁾, described in BS 8204-1 : 2003.

(1) Maximum permissible departure of 5 mm from the underside of a 2 m straight edge, resting in contact with the floor.

9.2 Any unsound plaster, render or screed should be removed to expose the substrate which is then cleaned with a stiff brush to remove loose material, laitance, salt residue, mould or adhesive. If mould is present the substrate should be treated with a fungicidal wash. The Certificate holder can advise on suitable materials and procedures to be used.

9.3 Uneven substrates should be dubbed out with a cement-sand (1:4) render or screed, to the tolerance described in section 9.1. They should be allowed to set before the membrane is fixed.

10 Walls

10.1 Power cables, points and light switches should preferably be remounted in front of the membrane.

10.2 Installation of the membrane is commenced at the top of the construction. Sheets are overlapped by 100 mm, ie two domes, or by the flanged edge. For horizontal joints, the lower sheet is always positioned in front of the upper sheet. Overlaps should be sealed using a run of Wykamol Rope placed along the flat area of the membrane between the two rows of domes or by the flanged edge using Wykamol Tape.

10.3 Alternatively, for vertical joints only, the sheets can be fixed flush and the joints overlapped with Wykamol Corner Detail.

10.4 The membrane is installed over windows and then cut away to expose them. For doors and other obstructions, the membrane is installed up to the perimeter. In both cases the gaps are sealed with Wykamol Corner Detail.

10.5 Fixings are made through the domes into holes drilled through the membrane. Wykamol Brick Plugs, to which Wykamol Rope has been applied around the rim, are inserted into the holes and tapped flush with the membrane. The Wykamol Rope forms a sealing gasket between the plug and membrane.

10.6 Spacing between fixings will depend on the application and the nature of the substrate, but, where it is intended to install plasterboard lining on timber battens, the spacing should be kept to a maximum of 600 mm.

10.7 Where timber battens are used they should be preservative treated, of minimum dimensions 25 mm by 38 mm, fixed into the plug's fixing hole using suitable screws with a maximum screwing-in depth of 40 mm plus the batten depth. If required, Wykamol Mastic is injected into the fixing holes to reduce the risk of water penetration.

10.8 In cases where a 'sealed' system is not being installed, the build-up of water vapour behind the membrane is controlled by venting into the room. To facilitate this, the membrane is installed with a 10 mm gap at the top, and a 20 mm gap at the bottom of the wall. Spacers measuring 3 mm by 200 mm are then fixed at 600 mm centres behind the skirting board and ceiling coving to ensure a ventilation gap (see Figure 3).

Alternatively, a proprietary ventilated skirting board or ceiling coving may be used.

Figure 3 Wall detail with dry lining (ventilated system)

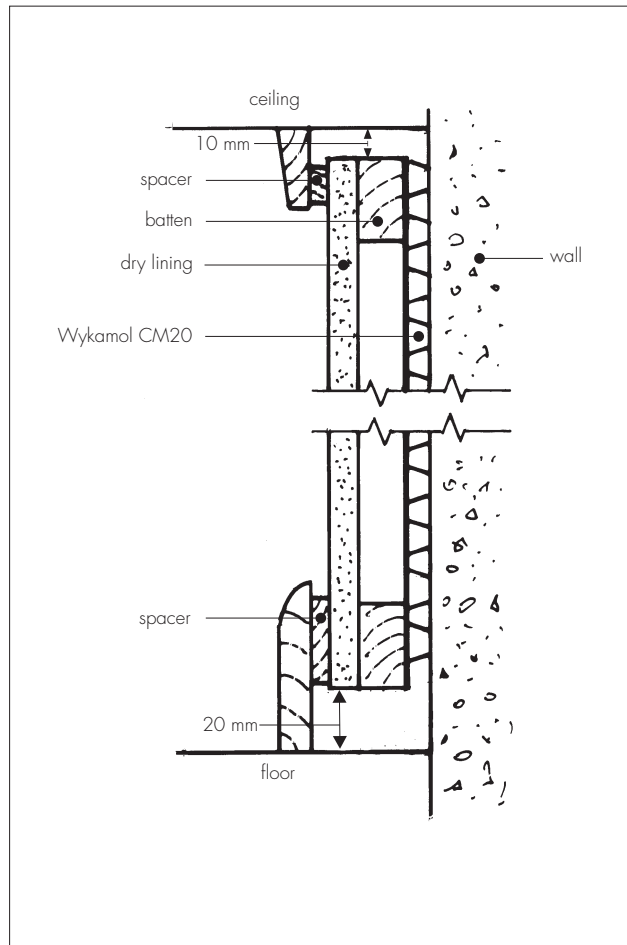

11 Floors

11.1 The membrane is laid out 'domes down' over the floor, and consecutive membrane widths are laid so an overlap of two interlocking domes is achieved. The overlapped joints should be sealed using Wykamol Rope in the flat section between domes, or where necessary sheets are laid flush and overlapped with Wykamol Corner Detail. If sheets with a flanged edge are used, these are rolled out ensuring the flanged edge on consecutive widths overlap the previous sheet. Joints are sealed using Wykamol Tape.

11.2 The membrane is cut within 5 mm to 10 mm of any pipes and services in the floor, and the gap filled with Wykamol Rope. A patch of membrane or Wykamol Corner Detail is overlaid and sealed to the service.

11.3 Fixings must not be applied through the floor membrane.

11.4 Where appropriate at wall/floor junctions and corners of the installation the membrane should be cut flush and the gap between the wall and floor membranes overlaid with Wykamol Corner Detail.

11.5 Alternatively, where a wall membrane is not being installed the floor membrane may be turned up by 100 mm at the walls. At corners, a cut is made and the membrane folded to form an edge-to-edge joint, then overlaid with Wykamol Corner Detail.

12 Dry lining

12.1 Where timber battens have been fixed to the wall, gypsum plasterboard to BS 1230-1 : 1985, or similar dry lining boards covered by a current Agrément Certificate, are fixed to the battens with galvanized screws or nails, positioned a minimum of 12 mm from the edge of the board. Care should be taken to ensure that penetration of the plasterboard screws or nails is less than batten depth to avoid puncturing the membrane.

12.2 Alternatively, linings can be free-standing framework, blockwork or similar. Where necessary these should be tied back by fixing into the Wykamol Brick Plug's fixing hole. Wykamol Mastic may be injected into the fixing hole to reduce the risk of water penetration.

13 Floor membrane coverings

13.1 If required, expanded polystyrene insulation boards, minimum density 30 kgm⁻³, are laid over the membrane.

13.2 The studs may, if required, be filled with dried sand, and then suitable tongue-and-groove panels should be selected in accordance with BS EN 12871 : 2001 and loose-laid over the membrane to within 10 mm of the walls. The panels are staggered and the joints sealed with either a thermoplastic wood adhesive to BS EN 204 : 2001, or a PVA adhesive to BS 4071 : 1966.

13.3 Alternatively, the membrane is covered by reinforced concrete or screed at least 65 mm thick, in accordance with BS 8204-1 : 2003. Care should be taken to ensure the membrane is not displaced when placing the concrete or screed over the membrane.

Technical Investigations

The following is a summary of the technical investigations carried out on Wykamol CM20.

14 Tests

Tests were carried out to determine:

- thickness
- resistance to short-term compression
- resistance to long-term loading
- nail tear resistance
- puncture resistance.

15 Investigations

15.1 The manufacturing process was examined, and details obtained of the raw material specifications and quality control procedures.

15.2 An assessment was made of the scope of use and durability of the system in relation to the generic properties of the membrane.

Bibliography

BS 4071 : 1966 *Specification for polyvinyl acetate (PVA) emulsion adhesives for wood*

BS 5250 : 2002 *Code of practice for control of condensation in buildings*

BS 6399-1 : 1996 *Loading for buildings — Code of practice for dead and imposed loads*

BS 6576 : 2005 *Code of practice for installation of chemical damp-proof courses*

BS 8102 : 1990 *Code of practice for protection of structures against water from the ground*

BS 8204-1 : 2003 *Screeds, bases and in-situ floorings — Concrete bases and cement sand levelling screeds to receive floorings — Code of practice*

BS EN 204 : 2001 *Classification of thermoplastic wood adhesives for non-structural applications*

BS EN 12871 : 2001 *Wood-based panels — Performance specifications and requirements for load bearing boards for use in floors, walls and roofs*

BWPDA Code of Practice COP3 : 1997 *Code of Practice for Installation of Chemical Damp-proof Courses*



On behalf of the British Board of Agrément

A handwritten signature in black ink, appearing to read 'G. A. Cooper'.

Date of issue: 31st March 2006

Chief Executive

British Board of Agrément

P O Box No 195, Bucknalls Lane
Garston, Watford, Herts WD25 9BA

Fax: 01923 665301

©2006

e-mail: mail@bba.star.co.uk
website: www.bbacerts.co.uk



For technical or additional information, contact the Certificate holder (see front page).
For information about the Agrément Certificate, including validity and scope, tel: Hotline 01923 665400, or check the BBA website.

WYKAMOL CM PLASTER

Product

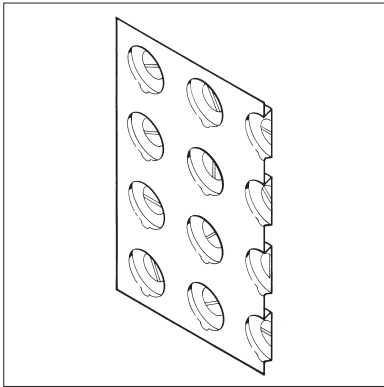

• THIS DETAIL SHEET RELATES TO WYKAMOL CM PLASTER, A MOULDED HDPE MEMBRANE, INCORPORATING UNDERCUT STUDS IN A DOVETAIL SHAPE WHICH FORM A KEY FOR PLASTER AND RENDER COATS AND FIXING/SEALING MATERIALS.

- The membrane is used on internal walls and vaulted ceilings, above or below ground in new or existing buildings over a contaminated or damp background to support a plaster or render coat or dry lining on plaster dabs.
- The membrane may also be used in conjunction with Wykamol CM8 and Wykamol CM20 membranes in sealed systems.
- The system should be installed by competent contractors.

This Detail Sheet must be read in conjunction with the Front Sheets, which give the system's position regarding the Building Regulations, general information relating to the product, and the Conditions of Certification.

Technical Specification

1 Description

1.1 Wykamol CM Plaster is a clear, high-density polyethylene (HDPE) membrane, moulded to form undercut studs, which act as a key to subsequently applied plaster or render (see Figure 1).

1.2 Characteristics of the membrane are:

thickness (mm)	0.5
stud height (mm)	5
weight per unit area (kgm^{-2})	0.48
roll sizes (m)	2.0 x 20
weight of roll (kg)	19 approx
air gap volume (lm^{-2})	3.2

1.3 Ancillary materials used with the membrane are:

- Wykamol Plaster Plug — a plastic, pre-drilled plug for fixing membrane to brick or stone (see Figure 2)
- Wykamol Rope — butyl rubber beading for sealing the membrane around pipes and openings, and to form a gasket between the plug and the membrane
- Wykamol Mastic — acrylic sealant for sealing the membrane around pipes and openings and at joints
- Wykamol Fibre Tape — butyl rubber tape, at least 100 mm wide, backed with non-woven polypropylene for sealing joints in the membrane
- Wykamol Corner Detail — butyl tape, 150 mm wide, backed with aluminium foil for sealing junctions between floors and walls, and for sealing joints at corners.

Figure 1 Wykamol CM Plaster

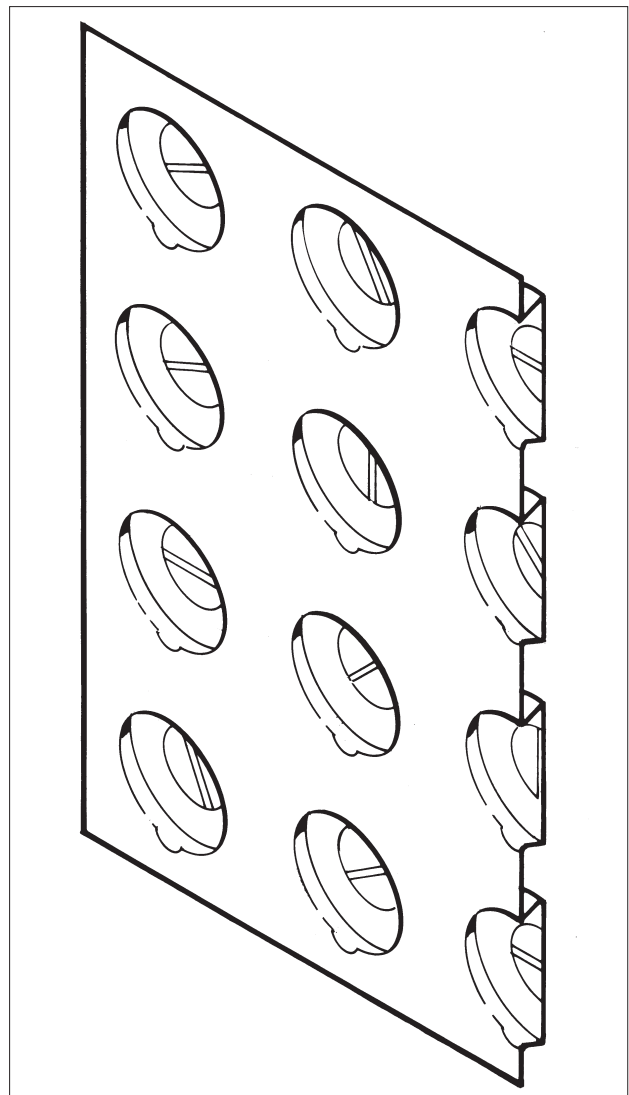
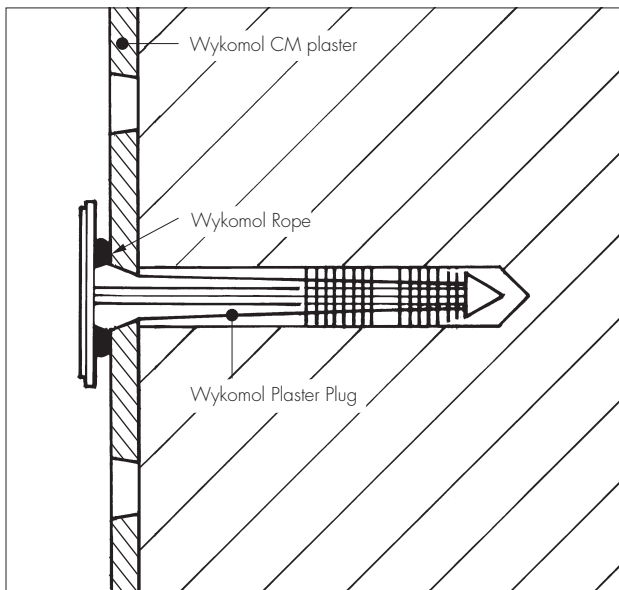

Figure 2 Wykamol Plaster Plug fixing detail



Design Data

2 General

2.1 Wykamol CM Plaster is satisfactory for use as a support for replastering/rendering, or for a dry lining fixing by plaster dabs over internal walls of all types of construction, in the following situations:

- damp walls in underground situations subject to high groundwater levels, and perennial moisture
- on vaulted ceilings of archways or cellars subject to dripping water
- in conjunction with a remedial dpc system where the walls have a high salt content and/or it is necessary to complete the installation immediately without allowing a period for initial drying
- over a wall which has a friable or painted surface, is contaminated with oil or mould, or has a high salt content
- as a waterproofing or 'tanking' in areas subject to vibration.

2.2 Depending on the application required and the site conditions, the membrane may be used as:

- a dry-lining for walls, ventilated into the room via aeration slots at the top and bottom of the wall
- a completely sealed system covering floor, wall and ceiling used, where appropriate, in conjunction with other Wykamol membranes covered by this Certificate, with provision made for disposing of water build-up behind the membrane via a sump and pump.

2.3 The system is satisfactory for use in Type C (drained protection) structural concrete constructions in accordance with BS 8102 : 1990, Clause 3.2.4.

3 Resistance to water and water vapour

3.1 The membrane is water resistant and has a high resistance to the transmission of water vapour. Consequently, the measures described in the *Installation* part of this Detail Sheet must be followed to ensure that, where the surface is damp, there is a flow

of air across it or that the membrane acts as a drainage layer and that there is no excessive build up of water behind the system.

3.2 All joints and fixings must be sealed with Wykamol sealing products, and drainage channels and gullies, or sumps and pumps should be installed as necessary to disperse excess or standing water.

3.3 Floors should have a drainage outlet point. There should be a fall towards the outlet point or a drainage channel made around the perimeter of the floor, to ensure water can flow to the outlet.

4 Resistance to salt transfer

The system provides an effective barrier to the transmission of salts or other contaminants from the substrate.

5 Impact resistance

The membrane, plastered, rendered or dry-lined, has a satisfactory resistance to soft and hard body impacts.

6 Wall-mounted fittings

Wall-mounted fittings (apart from lightweight items such as framed pictures) should be fixed (using recommended proprietary fixings) through the membrane and lining board, plaster or render to the loadbearing structure behind. Holes made in the membrane should be filled with a flexible sealant before inserting the fixing.

7 Durability

7.1 Under normal conditions of use, the system will provide an effective barrier to the transmission of salts, liquid water and water vapour for the life of the structure in which it is incorporated.

7.2 Regular maintenance of all gullies, sumps and pumps must be conducted to ensure that a build-up of water does not occur behind the membrane.

Installation

8 Survey in damp conditions

8.1 Where conditions are damp, a full survey is necessary by a specialist surveyor to diagnose the cause and to establish if treatment is required.

8.2 If rising damp is found, a remedial treatment is conducted in accordance with the relevant Agrément Certificate, BS 6576 : 2005 and the BWPDA Code of Practice COP3 : 1997.

8.3 Appropriate remedial measures are taken to rectify other causes of damp conditions or water ingress and to repair structural defects.

9 Surface preparation

9.1 Any unsound plaster or render should be removed to expose the substrate which is then cleaned with a stiff brush to remove any loose material, laitance, salt residue, mould or adhesive. If mould is present the substrate should be treated with a fungicidal wash. The Certificate holder can advise on suitable materials and procedures to be used.

9.2 Uneven substrates should be dubbed out with a cement-sand (1:4) render to achieve a flat finish, and allowed to set before fixing the membrane.

10 Walls and ceilings

General

10.1 Power cables, points and light switches preferably should be remounted in front of the membrane.

10.2 The membrane should always be used with the lower sheet placed in front of the higher sheet with a minimum overlap of two studs. All vertical and horizontal laps are made secure by the use of Wykamol Plaster Plugs fixed as close as possible to the edge of the membrane. The overlap is then wiped clean of dust and sealed with 100 mm wide Wykamol Fibre Tape applying equal overlap areas to each sheet of membrane.

10.3 Fixings are made through the spacing between four studs (not through the studs themselves) into holes drilled through the membrane into the substrate. Wykamol Plaster Plugs to which Wykamol Rope has been applied around the rim, are inserted into the holes and tapped flush with the membrane.

10.4 On difficult substrates the fact that the membrane is clear will allow the contractor to view the substrate through the membrane and choose the optimum site for each fixing.

10.5 Fixings are made at maximum spacings of 300 mm.

Ceilings

10.6 Ceilings to be covered should always have a fall, as per vaulted cellar constructions, to ensure water does not build up against the membrane or a joint. In addition to the requirements given in section 10.8, on ceilings the vertical drop between the ends of the two membrane sheets for horizontal overlaps should be a minimum of two studs.

10.7 The membrane should be adequately supported, to avoid the possibility of ponding.

10.8 At the end walls of vaulted constructions the membrane must be turned down onto the end wall by a minimum 300 mm (ie nine domes). The membrane is mitred as necessary to fit the curve of the ceiling, and the joint sealed with Wykamol Fibre Tape. The wall membrane should be cut to fit the curve of the ceiling, fixed in front of the ceiling membrane, and the gap sealed with Wykamol Tape, Rope or Mastic.

Walls

10.9 Installation of the membrane is commenced at the top of the construction. Joints are made by overlapping the membrane by a minimum of two studs.

10.10 The membrane is installed over windows and then cut away to expose them. For doors and other obstructions, the membrane is installed up to the perimeter. In both cases the gaps are sealed with Wykamol Fibre Tape or Corner Detail.

10.11 For above-ground applications, where the system is not sealed, standard metal edge lathing is fixed at the top and bottom of the membrane to maintain a 10 mm gap at wall/ceiling and a 20 mm gap at wall/floor junctions (see Figure 3).

10.12 Spacers measuring 3 mm by 200 mm are fixed at 600 mm centres behind the skirting board and ceiling coving to ensure a ventilation gap (see Figure 3). Alternatively, a proprietary ventilated skirting board or ceiling coving may be used.

Figure 3 Wall detail with plaster finish (ventilated system)

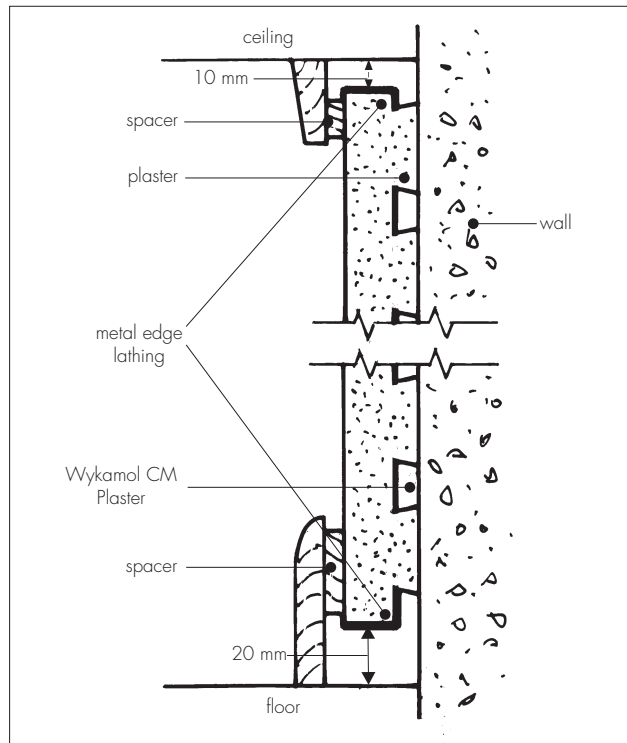

11 Plastering

11.1 Most common lightweight plasters, renovating plasters and one coat plasters can be applied to Wykamol CM Plaster using the procedures defined in BS 5492 : 1990, BS 8000-10 : 1995, BS EN 13914-2 : 2005 and/or the appropriate Agrément Certificate. When using sand/cement render, a mix of one part cement to six parts sand should be used, incorporating a suitable plasticiser. Where appropriate seek a recommendation from the Certificate holder.

11.2 The plaster should be a minimum total depth of 15 mm.

12 Dry lining

12.1 A gypsum-based adhesive is mixed and applied to the membrane in accordance with BS 8212 : 1995. The total area of contact between the adhesive and board surface should not be less than 20% of the board area.

12.2 Gypsum plasterboard to BS 1230-1 : 1985, or similar dry lining boards covered by a current Agrément Certificate, are pressed onto the plaster dabs and jointed in the usual manner. Temporary spacers approximately 20 mm to 25 mm high are positioned under the dry lining to support it during the curing period.

13 Finishing

13.1 The walls can be finished with a conventional skim coat plaster .

13.2 Where the membrane is installed internally and plastered, permanent decoration, such as vinyl papers or oil paint, may be applied. Temporary permeable decoration (necessary when a remedial dpc installation is replastered conventionally) is not necessary.

13.3 Once the plastered, dry-lined or rendered surface has dried, the surface can be painted or wallpapered using traditional methods and materials.

Technical Investigations

The following is a summary of the technical investigations carried out on Wykamol CM Plaster.

14 Tests

Tests were carried out to determine:

- nail tear resistance
- thickness
- impact resistance of plastered, rendered and dry-lined membrane.

15 Investigations

15.1 The manufacturing process was examined, including the methods adopted for quality control, and details were obtained of the quality and composition of the materials used.

15.2 Trial installations were conducted to assess the practicability of installation of the system and the methods used for plastering, rendering and dry lining.

15.3 An assessment was made of the scope of use and durability of the system in relation to the generic properties of the membrane.

Bibliography

BS 1230-1 : 1985 *Gypsum plasterboard — Specification for plasterboard excluding materials submitted to secondary operations*

BS 5492 : 1990 *Code of practice for internal plastering*

BS 6576 : 2005 *Code of practice for installation of chemical damp-proof courses*

BS 8000-10 : 1995 *Workmanship on building sites — Code of practice for plastering and rendering*

BS 8102 : 1990 *Code of practice for protection of structures against water from the ground*

BS 8212 : 1995 *Code of practice for dry lining and partitioning using gypsum plasterboard*

BS EN 13914-2 : 2005 *Design, preparation and application of external rendering and internal plastering — Design considerations and essential principles for internal plastering*

BWPDA Code of Practice COP3 : 1997 *Code of Practice for Installation of Chemical Damp-proof Courses*



On behalf of the British Board of Agrément

Date of issue: 31st March 2006

Chief Executive

British Board of Agrément

P O Box No 195, Bucknalls Lane
Garston, Watford, Herts WD25 9BA

Fax: 01923 665301

©2006

e-mail: mail@bba.star.co.uk
website: www.bbacerfs.co.uk



For technical or additional information, contact the Certificate holder (see front page).
For information about the Agrément Certificate, including validity and scope, tel: Hotline 01923 665400, or check the BBA website.