



## Marley Extrusions Ltd

Lenham  
Maidstone  
Kent ME17 2DE  
Tel: 01622 858888 Fax: 01622 858725

**Agrément  
Certificate  
No 88/1977**  
Second issue\*

Designated by Government  
to issue  
European Technical  
Approvals

## MARLEY UNDERGROUND DRAINAGE SYSTEM

Eléments de drainage souterrains  
Dränungssystem

### Product

• THIS CERTIFICATE REPLACES AND EXTENDS CERTIFICATE No 83/1065 AND RELATES TO THE MARLEY 110 mm AND 160 mm UNDERGROUND DRAINAGE SYSTEM, THE COMPONENTS OF WHICH ARE REFERRED TO IN THE ACCOMPANYING DETAIL SHEETS.

- The system is for use in domestic drains and public and private sewers.
- Components of the system can be used individually or in combination as described in the Detail Sheets.
- This Certificate does not cover the use of any of the products for untreated trade effluents where its suitability will depend on individual circumstances and where the manufacturer's advice must be followed.

These Front Sheets must be read in conjunction with the accompanying Detail Sheets, which provide information to specific systems.

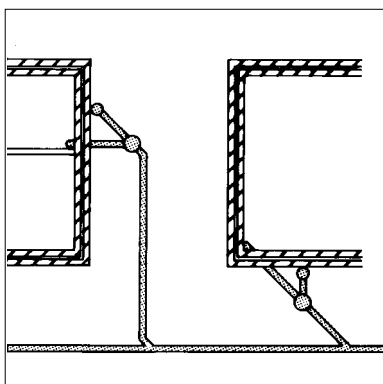

## Building Regulations — Detail Sheet 1

### 1 The Building Regulations 1991 (as amended 1994) (England and Wales)

 The Secretary of State has agreed with the British Board of Agrément the aspects of performance to be used by the BBA in assessing the compliance of drainage systems with the Building Regulations. In the opinion of the BBA, the Marley Underground Drainage System, if used in accordance with the provisions of this Certificate, will meet the relevant requirements.

Requirement:	H1(1)	Sanitary pipework and drainage
Comment:		See the marked up sections of the Design Data parts of the accompanying Detail Sheets.
Requirement:	H3	Rainwater drainage
Comment:		See the marked up sections of the Design Data parts of the accompanying Detail Sheets.
Requirement:	Regulations 7	Materials and workmanship
Comment:		The system is acceptable.

### 2 The Building Standards (Scotland) Regulations 1990 (as amended)

 In the opinion of the BBA, the Marley Underground Drainage System, if used in accordance with the provisions of this Certificate will satisfy the various Regulations as listed below.

Regulation:	10	Fitness of materials
Standard:	B2	Selection and use of materials, fittings, components and other manufactured products.
Comment:		The system is acceptable.
Regulation:	24	Drainage and sanitary facilities
Standard:	M2.1	Drainage system
Comment:		The system will meet the relevant requirements of this regulation. See the marked up sections of the Design Data parts in the accompanying Detail Sheets.

### 3 The Building Regulations (Northern Ireland) 1994 (as amended 1995)

 In the opinion of the BBA, the Marley Underground Drainage System, if used in accordance with the provisions of this Certificate will satisfy the various Building Regulations as listed below.

Regulation:	B2	Fitness of materials and workmanship
Comment:		The system is acceptable.
Regulation:	N2	Drainage systems
Regulation:	N5	Underground foul drainage
Regulation:	N7	Rainwater drainage
Comment:		The system will meet the relevant requirements of these Regulations. See the marked up sections of the Design Data parts in the accompanying Detail Sheets.

## Additional Information

The management systems of Marley Extrusions Ltd have been assessed and registered as meeting the requirements of EN ISO 9002 : 1994 by the British Standards Institution Quality Assurance (Certificate No FM 30637).

## Bibliography

BS EN ISO 9002 : 1994 *Quality systems — Model for quality assurance in production, installation servicing*

## Conditions of Certification

### 4 Conditions

4.1 Where reference is made in this Certificate to any Act of Parliament, Regulation made thereunder, Statutory Instrument, Code of Practice, British Standard, manufacturer's instruction or similar publication, it shall be construed as reference to such publication in the form in which it is in force at the date of this Certificate.

4.2 The quality of materials and the method of manufacture have been examined and found satisfactory by the BBA and must be maintained to this standard during the period of validity of this Certificate. This Certificate will remain valid for an unlimited period provided:

(a) the specification of the product is unchanged; and

(b) the manufacturer continues to have the product checked by the BBA.

4.3 This Certificate will apply only to the product that is installed, used and maintained as set out in this Certificate.

4.4 In granting this Certificate, the BBA makes no representation as to:

(a) the presence or absence of patent or similar rights subsisting in the product; and

(b) the legal right of the Certificate holder to market, install or maintain the product; and

(c) the nature of individual installations of the product, including methods and workmanship.

4.5 It should be noted that any recommendations relating to the safe use of this product which are contained or referred to in this Certificate are the minimum standards required to be met when the product is used. They do not purport in any way to restate the requirements of the Health & Safety at Work etc Act 1974, or of any other statutory or Common Law duties of care, or of any duty of care which exist at the date of this Certificate or in the future; nor is conformity with such recommendations to be taken as satisfying the requirements of the 1974 Act or of any present or future statutory or Common Law duties of care. In granting this Certificate, the BBA does not accept responsibility to any person or body for any loss or damage, including personal injury, arising as a direct or indirect result of the use of this product.



In the opinion of the British Board of Agrément, Marley Underground Drainage System is fit for its intended use provided it is installed, used and maintained as set out in this Certificate. Certificate No 88/1977 is accordingly awarded to Marley Extrusions Ltd.

On behalf of the British Board of Agrément

A handwritten signature in black ink, appearing to read 'P. C. Newson'.

Date of Second issue: 15th November 1996

Director

*\*Original Certificate issued 20th January 1988. This amended version includes revised Detail Sheet format, references to the revised Building Regulations and revised Conditions of Certification.*



**Marley Extrusions Ltd**

**Certificate No 88/1977**

**DETAIL SHEET 2**

*Fourth issue\**

**MARLEY UNDERGROUND DRAINAGE SYSTEM**

## BSI Kitemarked Components

• THIS DETAIL SHEET LISTS THE COMPONENTS IN THE MARLEY UNDERGROUND DRAINAGE SYSTEM CURRENTLY COVERED BY THE BSI KITEMARK CERTIFICATION SCHEME.



BSI Kitemark Licence No 5495  
issued to

Marley Extrusions Ltd, Lenham,  
Maidstone, Kent ME17 2DE.

**BS 4660 : 1989 Specification for unplasticized polyvinyl chloride (PVC-U) pipes and plastics fittings of nominal sizes 110 and 160 for below ground gravity drainage and sewerage.**

**BS EN 1401 Plastics piping systems for non-pressure underground drainage and sewerage. Unplasticized poly(vinylchloride) (PVC-U)**

**BS EN 1401-1 : 1998 Specifications for pipes, fittings and the system**

Kitemark certified pipe and fittings to BS 4660 : 1989 <sup>(1)</sup> BS EN 1401-1 : 1998	Manufacturer's catalogue No Nominal size	
	110 mm	160 mm
Pipe 3 m length	UL 403	
Pipe 6 m length	UL 406	UL 606
Pipe with ring seal socket 3 m length <sup>(2)</sup>	UP 403	UP 603
Pipe with ring seal socket 6 m length <sup>(2)</sup>	UP 406	UP 606
Coupling — double ring seal, straight	UE 406	
Coupling — double ring seal, straight slip	UE 405	
Loose pipe socket cement/ring seal	UE 400	UE 600
Double solvent socket	UES 401	
Triple socket	UE 402	
Adjustable bends socket/spigot	UB 47	UB 67
87½° socket/spigot short radius bend	UB 41	UB 61
87½° double socket long radius bend	UBL 488	
87½° long radius bend with 900 mm tail	UBL 49	
45° socket/spigot short radius bend	UB 45	UB 65
11¼° socket/spigot short radius bend	UB 46	
15° socket/spigot short radius bend		UB 68
22½° socket/spigot short radius bend	UB 48	
30° socket/spigot short radius bend		UB 69
45° double socket short radius bend	UB 455	
11¼° double socket short radius bend	UB 466	
22½° double socket short radius bend	UB 488	
87½° double socket short radius bend	UB 411	
Inspection pipe	UF 42	
45° equal socket/spigot branch	UY 46	UY 63
45° branch left hand access	UY 471	UY 631
45° branch right hand access	UY 472	UY 632
45° unequal branch socket/spigot 160 mm x 110 mm		UY 66
87½° equal branch	UY 400	
87½° equal branch	UY 401	
45° equal branch	UY 466	
45° branch 160 mm x 110 mm left hand access		UY 661
45° branch 160 mm x 110 mm right hand access		UY 662
45° double branch 110 mm x 110 mm	UY 404	
Pressure plug and access cap	UE 42	

continued

continued

# Electronic Copy

Kitemark certified pipe and fittings to BS 4660 : 1989 <sup>(1)</sup> BS EN 1401-1 : 1998	Manufacturer's catalogue No	
	Nominal size	
	110 mm	160 mm
Level invert reducer 110 mm spigot to 82.4 mm socket	URM 304	
Level invert reducer 160 mm spigot to 110 mm socket		URM 604
Straight coupling		UME 15C
Slip coupling		UME 16C
87° access bend (short radius)	UB 42	
45° long radius channel fitting bends		UCB 64L
87½° long radius channel fitting bends	UCB 48L	
90° long radius channel fitting bends		UCB 68L
Straight channel	UCC 4	UCC 6
Channel slippers left hand	USB 41	UCB 671
Channel slippers right hand	USB 42	UCB 672
Gully Q trap base	UG 44	
Trap gully	UG 42	
Bottle gully	UG 50	
45° rodding point terminal	URP 1	
Adaptor PVC-U spigot to Salt glaze/pitch fibre	UA 41	
Adaptor PVC-U spigot to vitrified clay	UA 49	

(1) Details of Kitemark certification schemes can be obtained from BSI Quality Assurance, P O Box 375, Milton Keynes MK14 6LL, Tel: Milton Keynes 01908 220908; Fax: 01908 220671.

(2) Pipes may be supplied with integral sockets or sockets fitted using solvent cement. Non-preferred lengths may be supplied.



On behalf of the British Board of Agrément

A handwritten signature in black ink, appearing to read 'P. C. Hewitt'.

Date of Fourth issue: 10th August 2001

Chief Executive

\*Original Detail Sheet 2 was issued on 20th January 1988. This amended version includes references to the revised BS 4660 : 1989 and BS EN 1401-1 : 1998.



Marley Extrusions Ltd

Certificate No 88/1977

**MARLEY UNDERGROUND DRAINAGE SYSTEM -INSTALLATION**

**DETAIL SHEET 3**  
Second issue\*

## Product

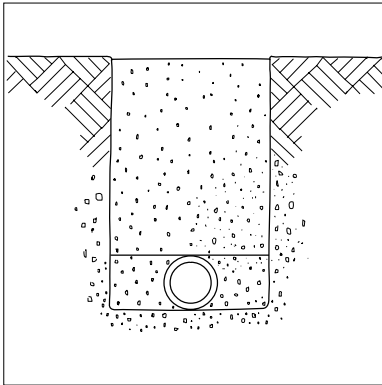

• THIS DETAIL SHEET RELATES TO THE INSTALLATION OF KITEMARKED MARLEY EXTRUSIONS 110 mm AND 160 mm DIAMETER PVC-U DRAINPIPES AND FITTINGS TO BS 4660 : 1989 (SEE DETAIL SHEET 2) AND PRODUCTS CERTIFICATED BY THE BBA AS DESCRIBED IN THIS CERTIFICATE.

*This Detail Sheet must be read in conjunction with the Front Sheets, which give the product's position regarding the Building Regulations and the Conditions of Certification, respectively.*

## Installation

### 1 General

Installation should be carried out in accordance with BS 5955 : Part 6 : 1980 BS 8301 : 1985 and this Detail Sheet.

### 2 Laying pipes

On trench bottom in granular material (see Figure 1).

Figure 1 Pipes laid on trench bottom

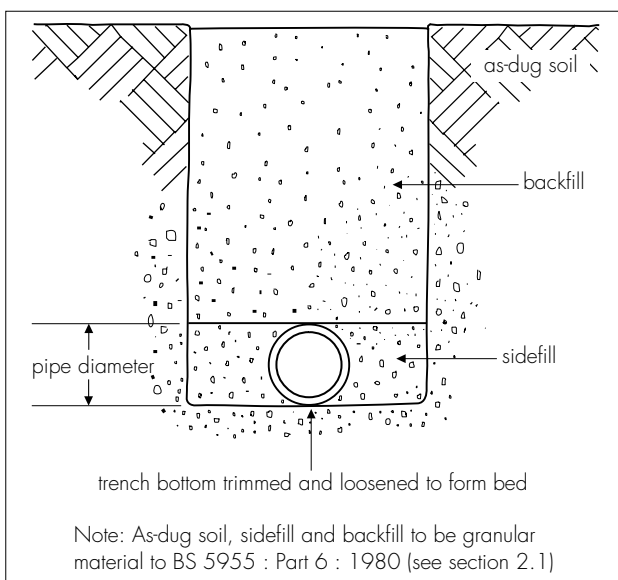

2.1 Where the as-dug material is suitable\* for use as bedding, the bottom of the trench may be trimmed to form the pipe bed.

\*Suitable material is defined as granular material in accordance with the recommendations of BS 5955 : Part 6 : 1980, Appendix A, having a nominal particle size not exceeding 10 mm or 14 mm for 110 mm and 160 mm diameter pipes respectively.

2.2 Small depressions should be made to accommodate the pipe sockets or couplings. After the pipe has been laid these should be filled carefully to ensure that no voids remain under, or around, the socket.

2.3 When the formation is prepared, the pipes should be laid upon it true to line and level within the specified tolerances. Each pipe should be checked and any necessary adjustments to level made by raising or lowering the formation, ensuring that the pipes finally rest evenly on the adjusted formation throughout the length of the barrels. Adjustment should never be made by local packing.

2.4 Where the formation is low and does not provide continuous support, it should be brought up to the correct level by placing and compacting suitable material.

**On granular beds** (see Figures 2 and 3)

2.5 When the as-dug material is not suitable as a bedding, a layer of suitable granular material (see section 2.1) must be spread evenly on the trimmed trench bottom before the pipes are installed. The trench should be excavated to allow for the thickness of granular bedding under the barrels.

2.6 The trench formation should be prepared, the bedding placed and the pipes laid in accordance with BS 5955 : Part 6 : 1980 and BS 8301 : 1985.

2.7 Where the as-dug material can be hand trimmed by shovel and is not puddled when walked upon, a 50 mm depth of bedding material may be used. In this case the material must be nominal 10 mm single-sized aggregate with no sharp edges, ie pea gravel (see Figure 2).

2.8 When the pipes are to be laid on rock, compacted sand or gravel, requiring mechanical

means of trimming, or in very soft or wet ground, the bedding should be a minimum of 100 mm in accordance with BS 5955 : Part 6 : 1980 (see Figure 3).

### 3 Sidefill

In all cases the sidefill must be of the same specification as the bedding material and extend to the level of the crown of the pipe and be placed and compacted in accordance with BS 5955 : Part 6 : 1980.

### 4 Backfill

Backfill above the level of the crown of the pipe must be in accordance with BS 5955 : Part 6 : 1980 (see Figures 1, 2 and 3).

Figure 2 Pipes laid on 50 mm minimum pea gravel bedding

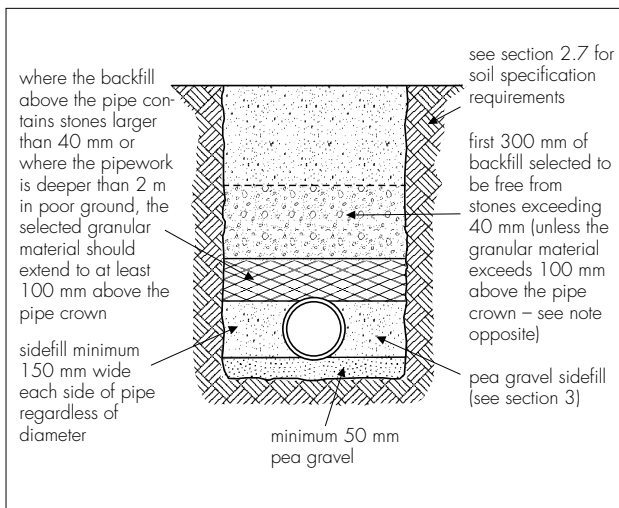
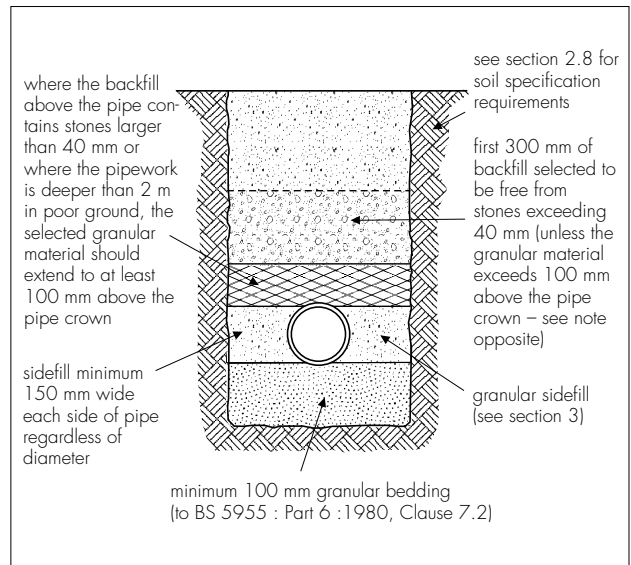

Figure 3 Pipes laid on 100 mm minimum granular bedding



## Bibliography

BS 4660 : 1989 Specification for unplasticized polyvinyl chloride (PVC-U) pipes and plastics fittings of nominal sizes 110 and 160 for below ground gravity drainage and sewerage

BS 5955 *Plastics pipework (thermoplastics materials)*  
Part 6 : 1980 Code of practice for the installation of unplasticized PVC pipework for gravity drains and sewers

BS 8301 : 1985 Code of practice for building drainage



On behalf of the British Board of Agrément

*P. C. Newson*

Date of Second issue: 15th November 1996

Director

\*Original Detail Sheet 3 was issued on 20th January 1988. This amended version includes references to the updated British Standards and the addition of the Bibliography.



**Marley Extrusions Ltd**

**Certificate No 88/1977**

**DETAIL SHEET 5**

*Third issue\**

## MARLEY SEALED ACCESS FITTINGS

### Product

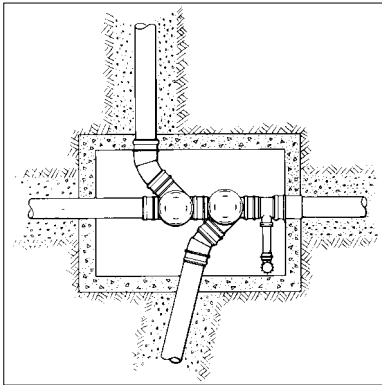

• THIS DETAIL SHEET RELATES TO THE USE OF MARLEY SEALED ACCESS FITTINGS IN TRADITIONALLY CONSTRUCTED MANHOLES AND SHALLOW INSPECTION CHAMBERS.

• Marley sealed access fittings in traditional manholes or shallow inspection chambers are for use in providing access to PVC-U drainage systems complying with BS 4660 : 1989, used in domestic underground drains, public and private sewers.

*This Detail Sheet must be read in conjunction with the Front Sheets, which give the product's position regarding the Building Regulations and the Conditions of Certification, respectively.*

### Technical Specification

#### 1 Description

1.1 The sealed access fittings listed in Table 1 are available in 110 mm and 160 mm pipe diameters, each incorporating ring seal sockets and spigot outlets. The access fittings incorporate a profiled insert held in position by an injection moulded threaded cap, and are made watertight with a ring seal to BS 2494 : 1990. When the insert is removed, the fitting allows a 150 mm diameter access point to the drain. Dimensions are detailed in Marley Extrusions Ltd's product brochure, *Marley Extrusions, Technical Information, Underground Drainage Systems*.

*Table 1 Sealed inspection fittings*

Product	Manufacturer's Catalogue No		
	110 mm	160 mm	160 mm x 110 mm
110 mm x 32 mm boss branch	UW 415		
Straight access pipe	UF 42		
Left hand access branch	UY 471	UY 631	UY 661
Right hand access branch	UY 472	UY 632	UY 662
Double access branch	UY 404		

1.2 Associated components and fittings are listed in Table 2.

*Table 2 Associated components/fittings*

	Manufacturer's Catalogue No
32 mm pipe muPVC	WPP33G
32 mm 91 1/2° bend polypropylene	WBP33G
32 mm access cap muPVC	WPA31G
32 mm clip PVC-U	WVC3G
250 mm riser/1 m long	UAR 1
324 mm square cover frame	UAC 03
300 mm square concrete lid	UEC 12

1.3 The injection moulded PVC-U fittings comply with the quality and colour requirements of BS 4660 : 1989. Continuous quality control is exercised during manufacture including stress relief, tensile strength and dimensional accuracy.

1.4 The 110 mm diameter ring seals are Type D to BS 2494 : 1990.

1.5 The 110 mm by 32 mm boss branch (UW 415) incorporates a socket suitable for receiving a 32 mm pipe. A stand pipe assembly must be constructed to enable surface water to be drained from the manhole (see Figure 1).

1.6 The shallow inspection chamber incorporates:

(a) a 110 mm sealed inspection fitting (references UF 42, UY 471 or UY 472, see Table 1).

(b) chamber body — 250 mm diameter PVC-U pipe to BS 5481 : 1977(1989) chamfered at both ends to fit the base section, the cover and the frame assembly. The risers are supplied in 375 mm lengths and have a minimum wall thickness of 4.9 mm.

(c) cover assembly — comprising an injection moulded PVC-U cover frame with a 250 mm solvent weld socket (UAC 03), and a concrete lid, (UEC 12) 300 by 300 by 50 mm, with a plastic insert to assist removal.

1.7 All fittings bear the manufacturer's identification mark, the nominal size and carry labels bearing the BBA identification mark incorporating the number of this Certificate. Where appropriate, components are marked with their respective BS Kitemark (see Detail Sheet 2 of this Certificate).

Figure 1 Manholes

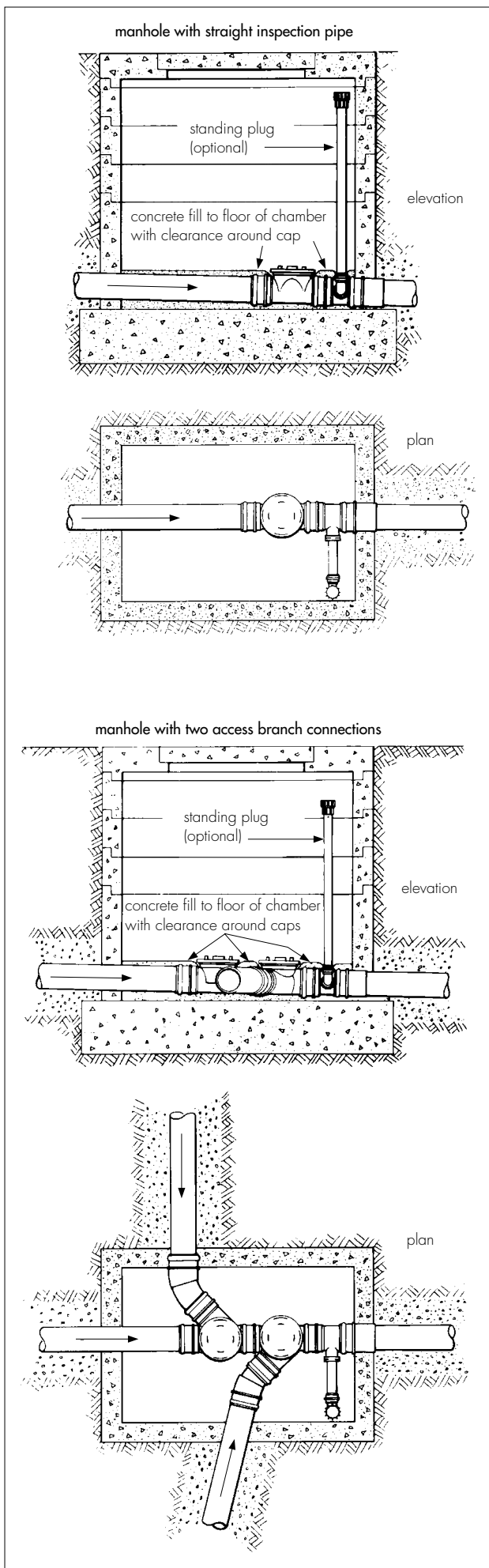

## 2 Delivery and site handling

2.1 The components are delivered to site in boxes or plastic bags containing similar items. The packaging should be retained during storage to minimise the risk of loss or damage.

2.2 If long-term storage in the open is envisaged, the fittings should be shaded from direct sunlight.

## Design Data

### 3 General

3.1 The Marley sealed access fittings are suitable for use in domestic drains designed in accordance with BS 8301 : 1985 for the conveyance, by combined or separate systems, of surface water and domestic sewage as is permitted to be discharged into public sewers by the Water Industry Act 1991 and surface water and sewage as is permitted and defined by the Sewerage (Scotland) Act 1968, and the Water and Sewerage Services (Northern Ireland) Order 1973.

3.2 Fittings used in manholes and shallow inspection chambers provide a satisfactory means of access to the drainage system for the purposes of rodding, removal of debris, inspection and testing.

3.3 The fittings are suitable for use in place of traditional channels in manholes. In all other respects the manholes must be constructed in accordance with BS 8301 : 1985.

3.4 The standing plug is an optional extra and provides a method of draining surface water that may infiltrate the manhole. However, if left out, there is no detrimental effect on the performance of the drain.

### 4 Strength

The components have adequate strength to resist loads associated with installation and subsequent use.

### 5 Performance of joints

5.1 Joints between the sealed inspection fittings and the drainage system complying with BS 4660 : 1989 will remain watertight under conditions of deformation and pipeline deflection in excess of those expected to occur with normal good drainage practice.

5.2 The dimensions of sockets and sealing rings are such as to give satisfactory joints. The performance of the joints will not be affected by thermal movement when the system is correctly installed and limited to the conditions of use set out in this Detail Sheet.

### 6 Watertightness

The access fittings, when correctly fitted, will not allow seepage of water into or from surrounding soil. The covers are watertight at an internal pressure of 0.35 bar.

## 7 Flow characteristics



The sealed inspection fittings will have the flow and self-cleaning properties normally associated with PVC-U pipes and fittings to BS 4660 : 1989.

## 8 Resistance to chemicals



The products will be unaffected by those types and quantities of chemicals associated with domestic effluent.

## 9 Resistance to elevated temperatures



The products will have adequate resistance to the temperatures likely to be found in domestic sewage.

## 10 Rodding and testing



10.1 Sealed access fittings in traditional manholes allow cleaning of the drains to be carried out using conventional flexible drain rods. Use of a rodding head incorporating a guide roller will facilitate rodding.

10.2 When using a mechanical rodding system with PVC-U pipes and fittings, toothed root cutters must not be used as these may cause damage to the drain.

10.3 The drain can be sealed for test purposes using either screw-expanding or inflatable drain stoppers.

## 11 Practicability of installation

The products can be installed easily under normal site conditions.

## 12 Durability



In the opinion of the BBA, when used in the context of this Detail Sheet, the materials from which the components are manufactured will not significantly deteriorate, and the system will have a life in excess of 50 years.

## Installation

### 13 Sealed access fittings in manholes.

13.1 The design and spacing of the manholes must be in accordance with BS 8301 : 1985.

13.2 Sealed access fittings may be installed within traditionally constructed manholes using single or combinations of the access fittings listed in Table 1 (see Figure 1).

13.3 If the standing plug is required, a 110 mm by 36 mm boss branch must be installed within the manhole to accept the 36 mm standpipe.

13.4 A concrete manhole base must be constructed in accordance with BS 8301 : 1985.

13.5 The sealed access fitting or fittings are then positioned and the drain connections made.

13.6 Concrete is then placed below the fitting and the manhole haunched (see Figure 1).

13.7 The manhole is then built to the required level and the standing plug assembly constructed (if required).

### 14 Sealed access fittings in shallow inspection chambers

14.1 The design and spacing of the shallow inspection chambers must be in accordance with BS 8301 : 1985.

14.2 The bedding and sidefill required up to the crown of the pipes connected to the access fitting must be in accordance with Detail Sheet 3 of this Certificate.

14.3 Joints between an access fitting and drain runs are made in the normal manner for push-fit joints in PVC-U pipe systems. The pipe spigot must be chamfered, deburred, cleaned and lubricated using the recommended lubricant. The pipe is then pushed into the socket on the access fitting, allowing a clearance for subsequent expansion.

14.4 The 250 mm diameter riser that forms the chamber body must not transfer load to the access fitting.

14.5 When using the cover and frame assembly, the top end of the pipe must be chamfered, if necessary, cleaned and lubricated before the cover assembly is pressed into position.

14.6 The chamber must be surrounded with granular material as shown in Figure 2.

14.7 Shallow inspection chambers are not suitable for locations with high water tables.

14.8 The access fittings must not be used in chambers where the drain invert level is greater than 600 mm below ground level.

14.9 The products are for use in locations inaccessible to motor vehicles.

14.10 Precautions should be taken to protect the product from damage during construction.

Figure 2 Typical shallow access chamber installation

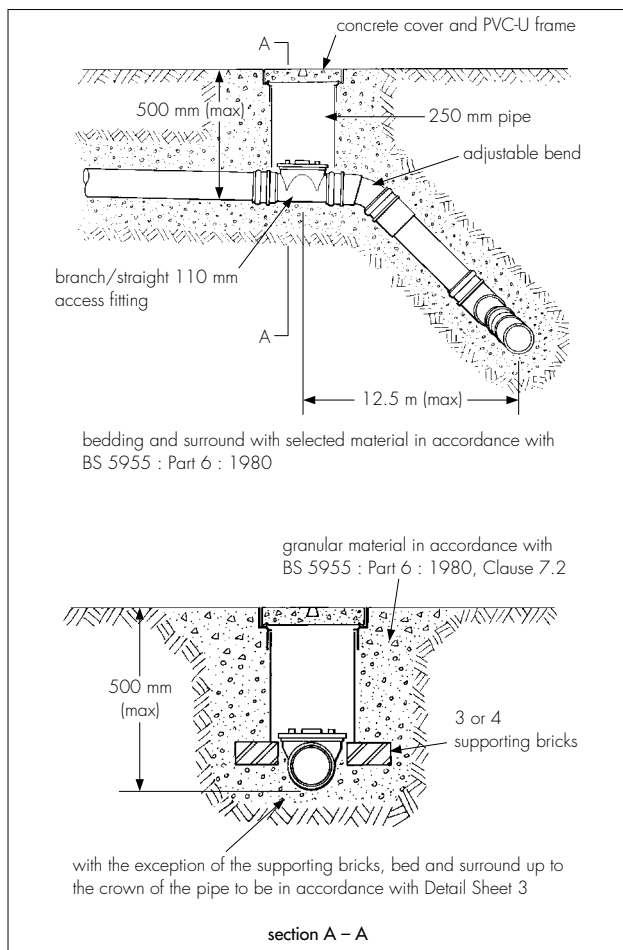

## Technical Investigations

The following is a summary of the technical investigations carried out on the Marley Sealed Access Fittings.

### 15 Tests

Tests were carried out to determine:

dimensional accuracy

Vicat softening point

impact resistance

practicability of installation

ease of rodding

resistance to an hydrostatic pressure of 0.35 bar.

### 16 Other investigations

16.1 An evaluation of existing data was made to assess the following:

resistance to chemicals

effect of temperature cycling

watertightness

suitability of materials

durability

16.2 The manufacturing process was examined including the methods adapted for quality control and details were obtained of the quality and composition of materials used.

16.3 An assessment was made of the flow characteristics.

## Bibliography

BS 2494 : 1990 *Specification for elastomeric seals for joints in pipework and pipelines*

BS 4660 : 1989 *Specification for unplasticized polyvinyl chloride (PVC-U) pipes and plastics fittings of nominal sizes 110 and 160 for below ground gravity drainage and sewerage*

BS 5481 : 1977(1989) *Specification for unplasticized PVC pipe and fittings for gravity sewers*

BS 5955 *Plastics pipework (thermoplastics materials) Part 6 : 1980 Code of practice for the installation of unplasticized PVC pipework for gravity drains and sewers*

BS 8301 : 1985 *Code of practice for building drainage*



On behalf of the British Board of Agrément

Date of Third issue: 15th November 1996

Director

\*Original Detail Sheet 5 was issued on 20th January 1988. This amended version includes references to the manufacturer's revised code numbers, revised British Standards and the addition of the Bibliography.



Marley Extrusions Ltd

Certificate No 88/1977

**DETAIL SHEET 6**

Second issue\*

## MARLEY RODDING ACCESS FITTINGS

### Product

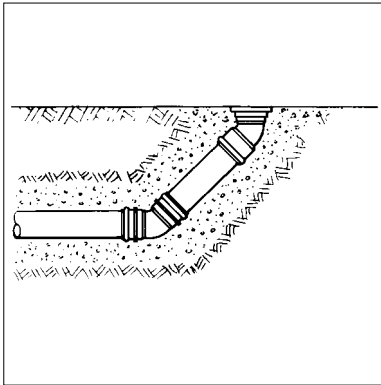

• THIS DETAIL SHEET REPLACES PART OF CERTIFICATE No 83/1065 AND RELATES TO THE MARLEY RODDING ACCESS FITTINGS.

• The Marley rodding access fittings are for use in providing access to PVC-U drainage systems complying with BS 4660 : 1989, used in domestic underground drains, public and private sewers.

This Detail Sheet must be read in conjunction with the Front Sheets, which give the product's position regarding the Building Regulations and the Conditions of Certification, respectively.

### Technical Specification

#### 1 Description

1.1 The rodding point consists of the components listed in Table 1.

Table 1 Rodding access fittings

Product	Manufacturer's catalogue No 110 mm
Adjustable bend 21° –90° (ring seal socket*)	UB 47
45° bend	UB 45
45° branch	UY 46
Pressure plug and access cap	UE 42
PVC-U cover frame	UAC 03
Concrete lid	UEC 12
Sealed rodding point terminal	URP 1

\* The adjustable bend is a two-piece fitting; the body may be cut in increments of 5° to produce a bend at angles between the limits shown.

1.2 The injection moulded PVC-U fittings comply with the quality and colour requirements of BS 4660 : 1989. Continuous quality control is exercised during manufacture including checks on stress relief, tensile strength and dimensional accuracy.

1.3 The 110 mm diameter ring seals are to BS 2494 : 1990.

1.4 The cover assembly comprises a concrete lid (UEC 12) 300 mm by 300 mm by 50 mm incorporating a plastic insert to assist removal, and is for use with an injection moulded PVC-U frame with a 250 mm solvent weld socket (UAC 03).

1.5 The fittings bear the manufacturer's identification mark and nominal size and carry the BBA identification mark incorporating the number of this Certificate. Where appropriate, components are marked with their respective BS Kitemark (see Detail Sheet 2 of this Certificate).

#### 2 Delivery and site handling

2.1 The components are delivered to site in boxes or plastic bags containing similar items. The packaging should be retained during storage to minimise the risk of loss or damage.

2.2 If long-term storage in the open is envisaged, the fittings should be shaded from direct sunlight.

### Design Data

#### 3 General

3.1 The Marley rodding access fittings are suitable for use in domestic drains designed in accordance with BS 8301 : 1985 for the conveyance, by combined or separate systems, of surface water and domestic sewage as is permitted to be discharged into public sewers by the Water Industry Act 1991 and surface water and sewage as is permitted and defined by the Sewerage (Scotland) Act 1968, and the Water and Sewerage Services (Northern Ireland) Order 1973.

3.2 The rodding access fittings are for use on a branch drain for rodding and testing only.

3.3 Rodding points must not be used on drains with invert at depths greater than 2 m.

3.4 Since it is not intended that debris be extracted from the drain through a rodding access fitting, an access point must be provided downstream.

#### 4 Strength

4.1 The components have adequate strength to resist loads associated with installation and subsequent use.

4.2 When installed over a screwed access fitting, the concrete cover and frame must be placed in a manner such that no direct load is transmitted onto

the access fitting. Rodding points must not be sited where vehicular traffic is likely to pass over the cover.

### 5 Performance of joints



5.1 Joints between the rodding access fittings and drainage systems complying with BS 4660 : 1989 will remain watertight under conditions of deformation and pipeline deflection in excess of those expected to occur with normal good drainage practice.

5.2 The dimensions of sockets and sealing rings are such as to give satisfactory joints. The performance of the joints will not be affected by thermal movement when the system is correctly installed and limited to the conditions of use set out in this Detail Sheet.

### 6 Watertightness



The products, when correctly installed, will not allow seepage of water into or from surrounding soil.

### 7 Flow characteristics



The access fittings have adequate flow characteristics. The rodding point and the means of connection to the drain will not affect the flow characteristics of the drain.

### 8 Resistance to chemicals



The access fittings will be unaffected by those types and quantities of chemicals associated with domestic effluent.

### 9 Resistance to elevated temperatures



The access fittings have adequate resistance to the temperatures likely to be found in domestic effluent.

### 10 Rodding and testing



10.1 The rodding access fittings allow cleaning of the drains to be carried out using conventional flexible drain rods. Use of a rodding head incorporating a guide roller will facilitate the rodding of sealed access fittings but the guide roller does not need to be used in rodding access fittings.

10.2 When using a mechanical rodding system with PVC-U pipes and fittings, toothed root cutters must not be used as these may cause damage to the drain.

10.3 The drain can be sealed for test purposes using either screw-expanding or inflatable drain stoppers.

### 11 Practicability of installation

The products can be installed easily under normal site conditions.



In the opinion of the BBA, when used in the context of this Detail Sheet, the materials from which the components are manufactured will not significantly deteriorate, and the system will have a life in excess of 50 years.

## Installation

### 13 Procedure

13.1 Installation of Marley rodding access fittings must be in accordance with BS 5955 : Part 6 : 1980, BS 8301 : 1985 and the manufacturer's product brochure *Marley Extrusions, Technical Information, Underground Drainage Systems*.

13.2 Precautions must be taken during and after installation to protect the fittings from damage due to site traffic.

13.3 When constructing rodding access points (see Figures 1 to 5) the pipes and fittings are to be laid on and surrounded with selected material in accordance with BS 5955 : Part 6 : 1980.

13.4 It is recommended that the area surrounding the access cover is paved with slabs or concrete to prevent the cover becoming concealed by grass.

Figure 1 Vertical rodding point

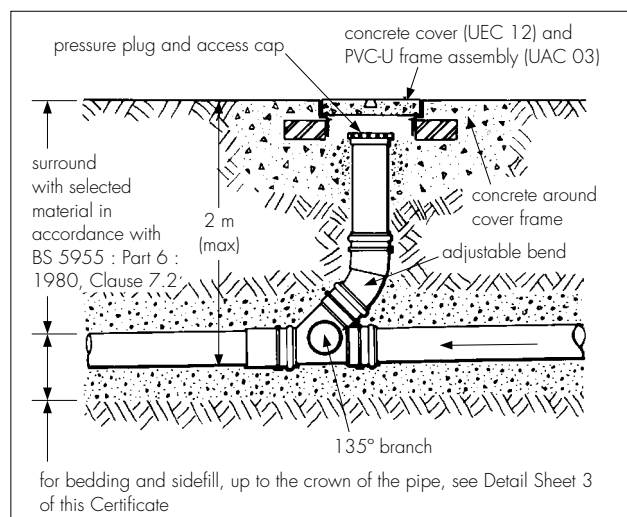

Figure 2 Intermediate rodding point

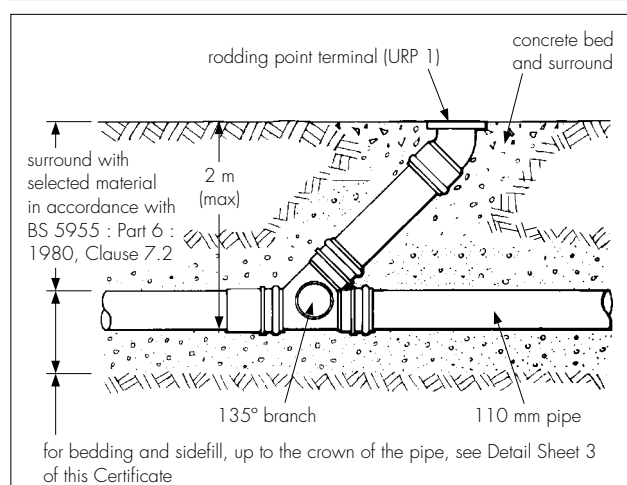

Figure 3 45° rodding point

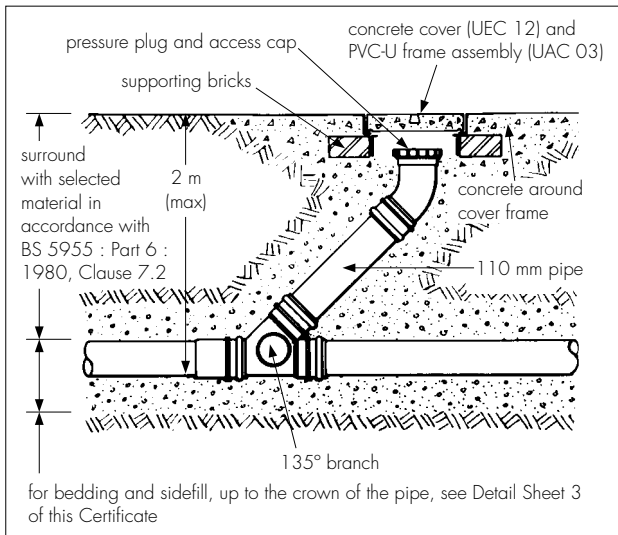

Figure 4 Head of drain rodding point

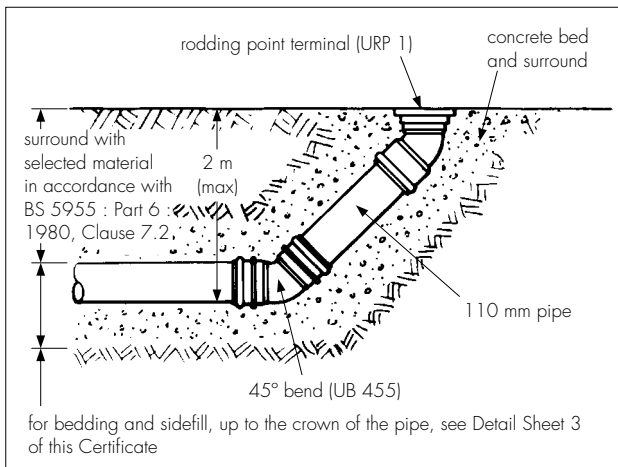
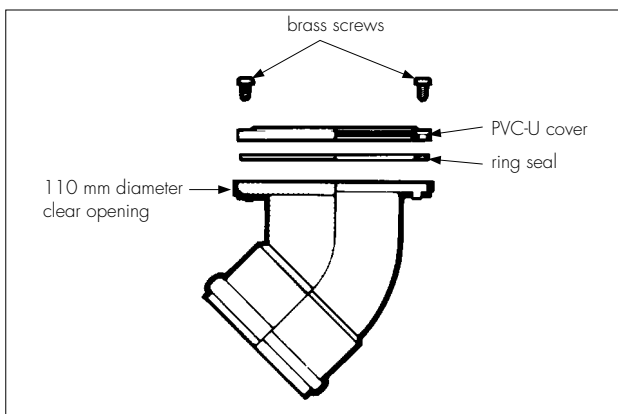

Figure 5 Rodding point terminal (URP 1)



## Technical Investigations

The following is a summary of the technical investigations carried out on the Marley Rodding Access Fittings.

### 14 Tests

Tests were carried out to determine:

- dimensional accuracy
- effect of thermal cycling to BS 4660 : 1989
- Vicat softening point
- impact resistance
- practicability of installation
- watertightness
- airtightness
- ease of rodding.

### 15 Other investigations

15.1 An evaluation of existing data was made to assess:

- resistance to chemicals
- suitability of materials
- durability

15.2 The manufacturing process was examined including the methods adapted for quality control and details were obtained of the quality and composition of materials used.

## Bibliography

BS 2494 : 1990 *Specification for elastomeric seals for joints in pipework and pipelines*

BS 4660 : 1989 *Specification for unplasticized polyvinyl chloride (PVC-U) pipes and plastics fittings of nominal sizes 110 and 160 for below ground gravity drainage and sewerage*

BS 5955 *Plastics pipework (thermoplastics materials)*

Part 6 : 1980 *Code of practice for the installation of unplasticized PVC pipework for gravity drains and sewers*

BS 8301 : 1985 *Code of practice for building drainage*



On behalf of the British Board of Agrément

Date of Second issue: 15th November 1996

Director

*\*Original Detail Sheet 6 was issued on 20th January 1988. This amended version includes references to the manufacturer's updated catalogue code numbers, the updated British Standards and the addition of the Bibliography.*



Marley Extrusions Ltd

**MARLEY RIBBED PVC-U UNDERGROUND DRAINAGE FITTINGS**

Certificate No 88/1977

**DETAIL SHEET 7**  
Third issue\*

## Product

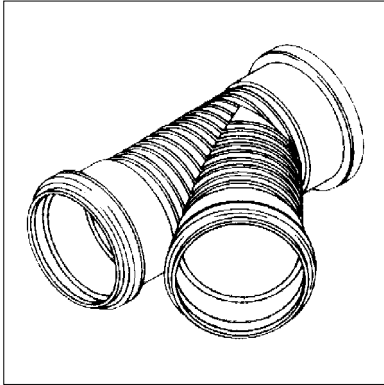

- THIS DETAIL SHEET RELATES TO MARLEY RIBBED PVC-U 160 mm AND 110 mm DIAMETER UNDERGROUND DRAINAGE FITTINGS.
- The fittings are for use with pipes complying with BS EN 1401-1 : 1998.
- This Detail Sheet does not cover the use of the fittings for untreated trade (non-domestic) effluents.

*This Detail Sheet must be read in conjunction with the Front Sheets and Detail Sheet 1, which give Conditions of Certification and the product's position regarding the Building Regulations, respectively.*

## Technical Specification

### 1 Description

1.1 Marley Ribbed PVC-U Underground Drainage Fittings are solid wall externally rib-reinforced, with a smooth bore and are available in socket/spigot or all-socketed format. The fittings are for use with all classes of pipe to BS EN 1401-1 : 1998 but are specifically designed to meet the SN4 class in line with UK practice. They also meet the requirements of prEN 13476-1 : 2000. Standard ring seals are supplied with the fittings.

1.2 The fittings are golden brown in colour and injection moulded in PVC-U. Ring seals are type

WC elastomeric ring seals to BS EN 681-1 : 1996. The range of fittings covered by this Detail Sheet is shown in Table 1.

1.3 Quality control tests are carried out continuously during manufacture and include visual and dimensional checks and stress relief testing.

1.4 Each fitting is marked with the manufacturer's name, product code and the BBA identification mark.

### 2 Delivery and site handling

The fittings are supplied in boxes, plastic bags or shrink-wrapped form. When long-term storage is envisaged the fittings must be protected from direct sunlight and away from any heat source.

Table 1 Ribbed fittings

### Coupling (double socket)

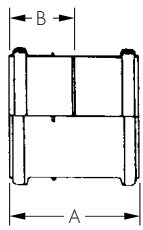

Size (mm)	Code	Dimension (mm)	
		A	B
160	UME 15C	170	83

### Slip coupling (double socket)

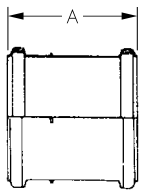

Size (mm)	Code	Dimension A (mm)
160	UME 16C	170

### Bends (double socket)

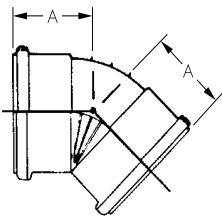

Size (mm)	Code	Angle	Dimension A (mm)
110	UB 455R	45	75
110	UB 4300R	30	57
110	UB 4155R	15	50
160	UMB 19C	87½	200
160	UMB 14C	45	115
160	UMB 13C	30	105
160	UMB 11C	15	95

### Bends (socket/spigot)

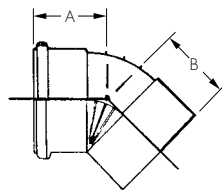

Size (mm)	Code	Angle	Dimension (mm)	
			A	B
110	UB 45R	45	75	85
110	UB 430R	30	57	78
110	UB 415R	15	50	69

### Equal branch (double socket)

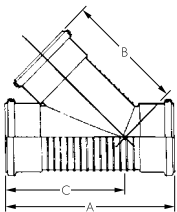

Size (mm)	Code	Angle	Dimension (mm)		
			A	B	C
110	UY 400R	87½	245	135	—
110	UY 466R	45	280	200	200
160	UMY 13C	87½	376	180	—
160	UMY 11C	45	400	280	280

### Unequal branch (double socket)

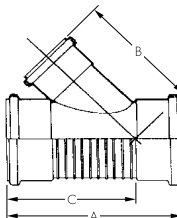

Size (mm)	Code	Angle	Dimension (mm)		
			A	B	C
160 x 110	UMY 10C	87	316	232	236
160 x 110	UMY 12C	87	313	170	—

### Equal branch (socket/spigot)

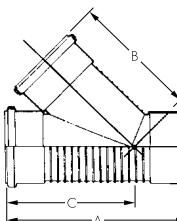

Size (mm)	Code	Angle	Dimension (mm)		
			A	B	C
110	UY 401R	87½	250	135	—
110	UY 46R	45	300	200	200

## Design Data

### 3 General

 Marley Ribbed PVC-U Underground Drainage Fittings have been assessed for use with pipes complying with BS EN 1401-1 : 1998 in underground drains, public and private sewers, for the conveyance, by combined or separate systems, of surface water and domestic sewage as is permitted to be discharged into public sewers by the Water Industry Act 1991, Sewerage (Scotland) Act 1968 and the Water and Sewerage Services (Northern Ireland) Order 1973.

### 4 Strength

 The fittings have adequate strength to resist loads associated with installation and with subsequent use in the situations defined in this Detail Sheet.

### 5 Performance of joints

 5.1 The performance of joints will not be adversely affected by thermal expansion or contraction when correctly made.

5.2 Joints with the pipe remain watertight under conditions of pipeline movement in excess of those expected to occur in normal good drainage practice.

### 6 Flow characteristics

 When used in underground drainage systems designed and installed in accordance with the recommendations given in this Detail Sheet, the fittings will not adversely affect the flow characteristics of the system.

### 7 Resistance to chemicals

7.1 The fittings are suitable for use where pipes and fittings to SN4 or SN8 of BS EN 1401-1 : 1998 are normally used. They have adequate resistance to the type and quantity of chemicals likely to be found in domestic sewage.

7.2 Details of the chemical resistance of PVC-U are given in CP 312-1 : 1973.

### 8 Resistance to elevated temperature

The fittings have adequate resistance to temperatures likely to be found in domestic sewage.

### 9 Practicability of installation

The fittings are installed easily under normal site conditions. The joints are push-fit and are achieved easily by hand.

### 10 Rodding

Drains incorporating the fittings can be easily rodded using conventional flexible drain rods. Toothed root cutters, as used with some mechanical cleaning systems, could damage the fittings and should not be used.

### 11 Durability



In the opinion of the BBA, no significant deterioration of the product will take place and the fittings will have a life equivalent to that of fittings to SN4 of BS EN 1401-1 : 1998.

## Installation

### 12 General

Drain and sewer systems utilising the fittings should be installed in accordance with the recommendations of BS EN 1610 : 1998, BS 5955-6 : 1980 and the recommendations given in Detail Sheet 3 of this Certificate.

### 13 Procedure

13.1 The pipe end and the inside of the socket must be clean and free from grit, dust or dirt.

13.2 When jointing with PVC-U pipe to BS EN 1401-1 : 1998, lubricant should be applied evenly to the chamfered pipe end and to the seal of the fitting. The pipe end is then inserted into the socket and pushed fully home.

13.3 A lubricant is supplied by the manufacturer for use with the fittings.

13.4 The fittings must have adequate protection against damage from site traffic.

The following is a summary of the technical investigations carried out on Marley Ribbed PVC-U Underground Drainage Fittings.

### 14 Tests

Tests were carried out to determine:

- effect of combined temperature and external load to prEN 13476-1 : 2000
- watertightness of joints under conditions of pipe deformation and hydrostatic pressure to BS EN 1401-1 : 1998
- watertightness of joints under conditions of angular deflection and hydrostatic pressure to BS EN 1401-1 : 1998
- Vicat softening temperature to BS EN 1401-1 : 1998
- stress relief
- dimensional accuracy
- short-term stiffness
- impact resistance
- tensile strength.

### 15 Other investigations

15.1 An examination was made of data relating to:

- resistance to chemicals
- flow characteristics
- resistance to high pressure water jetting.

15.2 The manufacturing process was examined, including the methods adopted for quality control, and details were obtained of the quality and composition of the materials used.

## Bibliography

BS 5955 *Plastics pipework (thermoplastics materials)*  
BS 5955-6 : 1980 *Code of practice for the installation of unplasticized PVC pipework for gravity drains and sewers*

BS EN 681 *Elastomeric seals. Material requirements for pipe joint seals used in water and drainage applications*

BS EN 681-1 : 1996 *Vulcanized rubber*

BS EN 1401 *Plastics piping systems for non-pressure underground drainage and sewerage — Unplasticized poly (vinyl chloride) (PVC-U)*

BS EN 1401-1 : 1998 *Specifications for pipes, fittings and the system*

BS EN 1610 : 1998 *Construction and testing of drains and sewers*

CP 312 *Code of practice for plastics pipework (thermoplastics material)*

CP 312-1 : 1973 *General principles and choice of material*

prEN 13476 *Thermoplastics piping systems for non-pressure underground drainage and sewerage — structured wall pipe systems for PVC-U, PP and PE*

prEN 13476-1 : 2000(May) *Specification for pipes, fittings and the system*



On behalf of the British Board of Agrément

A handwritten signature in black ink, appearing to read 'P. C. Newson', is written over a light grey background.

Date of Third issue: 10th August 2001

Chief Executive

*\*Original Detail Sheet 7 issued 29th March 1994. This amended version includes additional 110 mm fittings to the range.*