



Marley Extrusions Ltd

Lenham
Nr Maidstone
Kent ME17 2DE
Tel: 01622 858888 Fax: 01622 858725

**Agrément
Certificate
No 98/3486**

Designated by Government
to issue
European Technical
Approvals

MARLEY QUANTUM HIGHWAY PVC-U TWINWALL SURFACE WATER DRAINAGE SYSTEM

Systèmes de canalisations d'évacuation
Abflußleitungen

Product

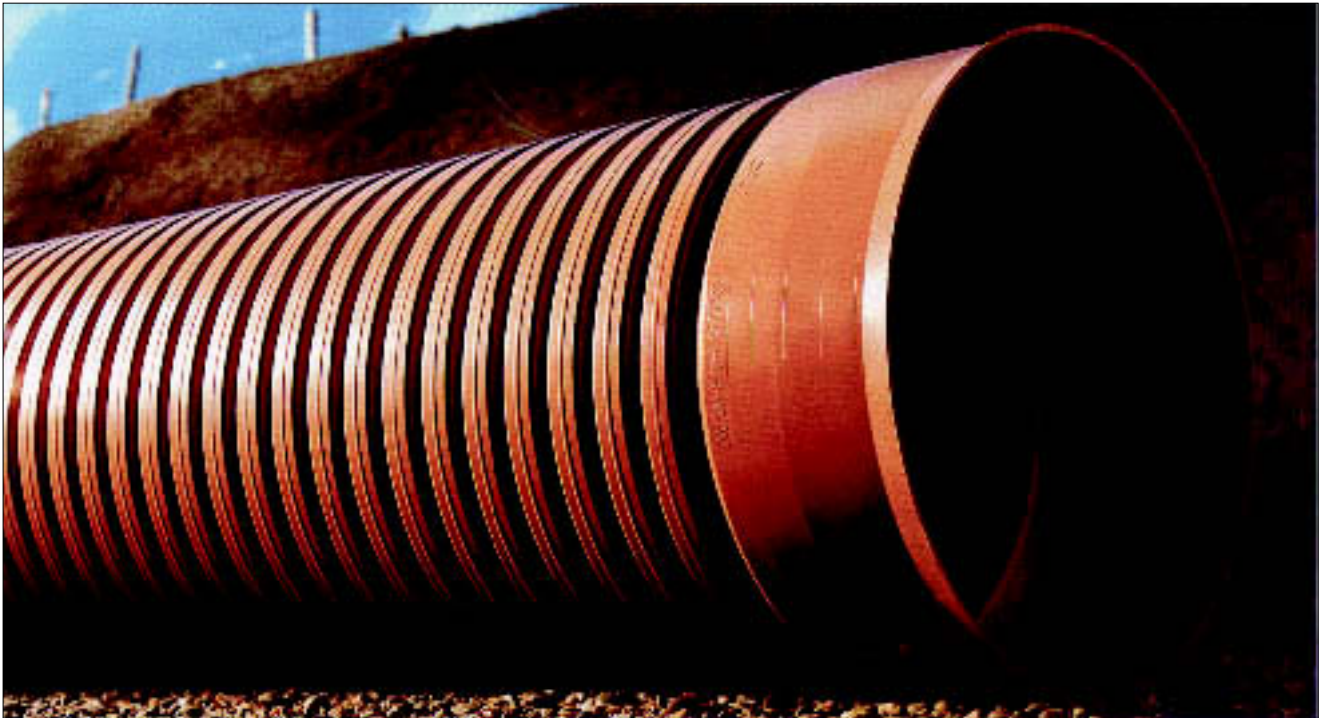

• THIS CERTIFICATE RELATES TO THE MARLEY QUANTUM HIGHWAY PVC-U TWINWALL SURFACE WATER DRAINAGE SYSTEM, THE COMPONENTS OF WHICH ARE REFERRED TO IN THE ACCOMPANYING DETAIL SHEET.

• The system is for use underground for the conveyance of surface water when pipes and fittings to SN2 or SN4 of BS EN 1401-1 : 1998 can be used.

• This Certificate does not cover the use of the products for domestic sewage, combined sewerage systems or untreated trade effluents.

These Front Sheets must be read in conjunction with the accompanying Detail Sheet, which provides information to specific components.

Regulations — Detail Sheet 1

1 The Building Regulations 1991 (as amended 1994) (England and Wales)

 The Secretary of State has agreed with the British Board of Agrément the requirements of the Building Regulations to which surface water pipe can contribute in achieving compliance. In the opinion of the BBA, the Marley Quantum Highway PVC-U Twinwall Surface Water Drainage System, if used in accordance with the provisions of this Certificate, will contribute to meeting the relevant requirements.

Requirement:	H3	Rainwater drainage
Comment:		The system will convey the flow of rainwater and minimise the risk of blockages or leakage.
Requirement:	Regulation 7	Materials and Workmanship
Comment:		The system is acceptable.

2 The Building Standards (Scotland) Regulations 1990 (as amended)

 In the opinion of the BBA, the Marley Quantum Highway PVC-U Twinwall Surface Water Drainage System, if used in accordance with the provisions of this Certificate, will satisfy or contribute to satisfying the various Regulations as listed below.

Regulation:	10	Fitness of materials
Standard:	B2.1	Selection and use of materials and components
Comment:		The system is acceptable.

continued

Electronic Copy

Regulation	24	Drainage and sanitary facilities
Standard:	M2.1	Drainage system
Comment:	The system will meet the relevant requirements of this Standard.	

3 The Building Regulations (Northern Ireland) 1994 (as amended 1995 and 1997)



In the opinion of the BBA, the Marley Quantum Highway PVC-U Twinwall Surface Water Drainage System, if used in accordance with the provisions of this Certificate, will satisfy the various Building Regulations as listed below.

Regulation:	B2	Fitness of materials and workmanship
Comment:	The system is acceptable.	
Regulation:	N7	Rain-water drainage
Comment:	The system will meet the relevant requirements of this Regulation.	

4 Construction (Design and Management) Regulations 1994

Information in this Certificate may assist the client, planning supervisor, designer and contractors to address their obligations under these Regulations.

See sections: 1 Description, 2 Delivery and site handling, and 9 Installation.

Conditions of Certification

5 Conditions

5.1 Where reference is made in this Certificate to any Act of Parliament, Regulation made thereunder, Statutory Instrument, Code of Practice, British Standard, manufacturer's instruction or similar publication, it shall be construed as reference to such publication in the form in which it is in force at the date of this Certificate.

5.2 The quality of materials and the method of manufacture have been examined and found satisfactory by the BBA and must be maintained to this standard during the period of validity of this Certificate. This Certificate will remain valid for an unlimited period provided:

- (a) the specification of the product is unchanged; and
- (b) the manufacturer continues to have the product checked by the BBA.

5.3 This Certificate will apply only to the product that is installed, used and maintained as set out in this Certificate.

5.4 In granting this Certificate, the BBA makes no representation as to:

- (a) the presence or absence of patent or similar rights subsisting in the product; and
- (b) the legal right of the Certificate holder to market, install or maintain the product; and
- (c) the nature of individual installations of the product, including methods and workmanship.

5.5 It should be noted that any recommendations relating to the safe use of this product which are contained or referred to in this Certificate are the minimum standards required to be met when the product is used. They do not purport in any way to restate the requirements of the Health & Safety at Work etc Act 1974, or of any other statutory or Common Law duties of care, or of any duty of care which exist at the date of this Certificate or in the future; nor is conformity with such recommendations to be taken as satisfying the requirements of the 1974 Act or of any present or future statutory or Common Law duties of care. In granting this Certificate, the BBA does not accept responsibility to any person or body for any loss or damage, including personal injury, arising as a direct or indirect result of the use of this product.



In the opinion of the British Board of Agrément, the Marley Quantum Highway PVC-U Twinwall Surface Water Drainage System is fit for its intended use provided it is installed, used and maintained as set out in this Certificate. Certificate No 98/3486 is accordingly awarded to Marley Extrusions Ltd.

On behalf of the British Board of Agrément

Date of issue: 31st March 1998

Director





Marley Extrusions Ltd

MARLEY QUANTUM HIGHWAY 150 mm, 225 mm AND 300 mm SURFACE WATER DRAINAGE PIPES AND FITTINGS

Certificate No 98/3486

DETAIL SHEET 2

Product

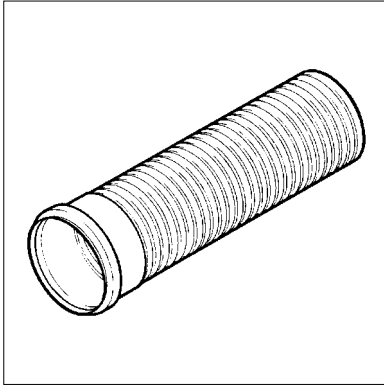

• THIS DETAIL SHEET RELATES TO MARLEY QUANTUM HIGHWAY 150 mm, 225 mm AND 300 mm PVC-U TWINWALL PIPES AND FITTINGS FOR SURFACE WATER DRAINAGE.

• This Certificate covers the use of the pipe and fittings for surface water only.

This Detail Sheet must be read in conjunction with the Front Sheets, which give the product's position regarding the Building Regulations and the Conditions of Certification, respectively.

Technical Specification

1 Description

1.1 Marley Quantum Highway 150 mm, 225 mm and 300 mm twinwall pipes are manufactured in golden brown PVC-U by a twin extrusion process. Two PVC-U pipes are extruded simultaneously, one inside the other, and heat welded together in one continuous process.

1.2 The pipe is available with one end plain and the other with an integral socket. One seal, to be fitted to the plain end, is supplied with each length. The seals are type WC to BS EN 681-1 : 1996.

1.3 The outer wall is corrugated and the inner wall is smooth finished. Details and dimensions of the pipe and socket are shown in Table 1 and Figures 1 and 2.

1.4 Quantum Highway fittings are golden brown in colour and manufactured in PVC-U with socketed ends. The sockets are not ribbed and have the same socket depths as the corresponding diameter of pipe socket. Where appropriate, the body of the 150 mm fittings is ribbed; the 225 mm and 300 mm fittings are not ribbed and are either formed from pipe to SN4 of BS EN 1401-1 : 1998 or are injection moulded. The range of fittings covered by this Detail Sheet is detailed in Table 2.

1.5 Continuous quality control is exercised during manufacture. Checks include:

Pipes

dimensional accuracy
weight
impact resistance
heat reversion/delamination
stiffness.

Fittings

dimensional accuracy
stress relief of injection moulded products.

1.6 The manufacturer's name, diameter of the pipe and the BBA logo incorporating the number of this Certificate are ink-jet printed along each length of pipe.

Table 1 Nominal dimensions

Nominal pipe diameter	External dia d_1 (mm)	Internal dia d_2 (mm)	P (mm)	t_1 (mean) (mm)	t_2 (mean) (mm)	Length L_1 (mm)	Weight (kgm^{-1})	Integral socket	
								Length L_2 (mm)	Diameter d_3 (nom) (mm)
150	160	148	16	0.63	0.80	6000	1.25	90	161
225	250	230	24	1.00	1.10	6000	2.75	125	251
300	329	302	31.5	1.30	1.40	6000	4.65	110	330

Figure 1 Twinwall pipe

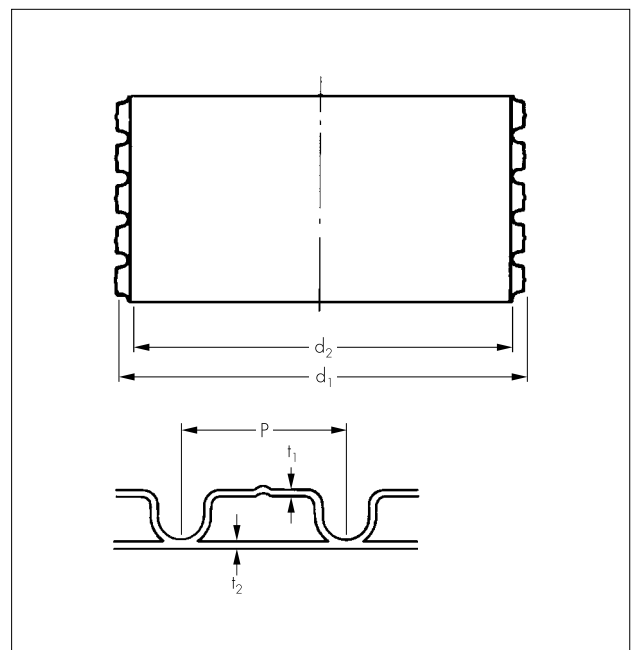
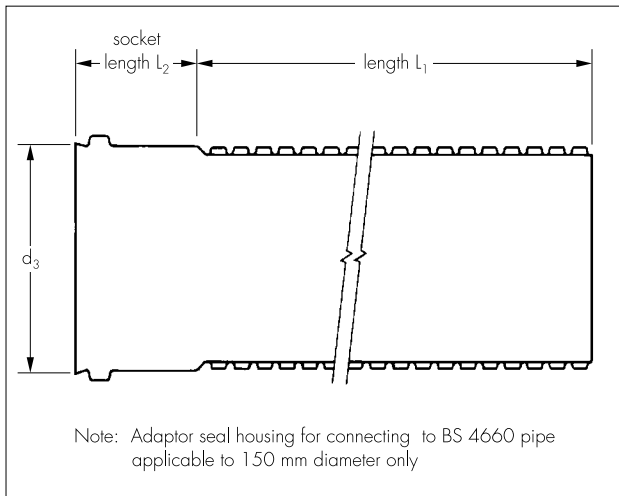
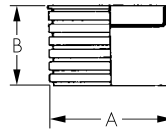

Figure 2 Pipe socket



Socket plug (push-fit in socket)



Size (mm)	Code	Dimension (mm)	
		A	B
150	UMJ1Q	160	100
225	UMJ21	250	130

Coupling (double socket)

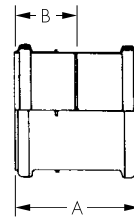

Size (mm)	Code	Dimension (mm)	
		A	B
150	UME15Q	170	83
225	UME25	220	94
300	UME35	237	110

Table 2 Fittings

Bends (double socket)

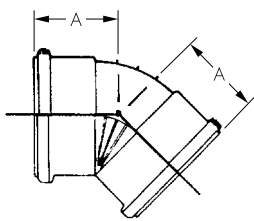

Size (mm)	Code	Angle	Dimension A (mm)
150	UMB19Q	87½	200†
150	UMB14Q	45	115
150	UMB13Q	30	105
150	UMB11Q	15	95
225	UMB29	90	595†
225	UMB24	45	160
225	UMB23	30	145
225	UMB21	15	125
300	UMB39	90	730†
300	UMB34	45	195
300	UMB33	30	175
300	UMB31	15	150

Slip coupling (double socket)

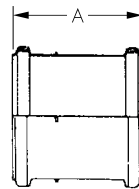

Size (mm)	Code	Dimension A (mm)
150	UME16Q	170
225	UME26	190
300	UME36	220

Equal branch (socket)

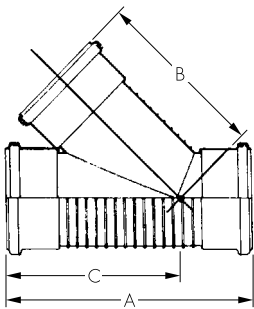

Size (mm)	Code	Angle	Dimension (mm)		
			A	B	C
150	UMY13Q	87½	376	180	150†
150	UMY11Q	45	400	280	280
225	UMY22	45	655	430	460
225	UMY33	45	800	540	575

Level invert reducer (double socket)

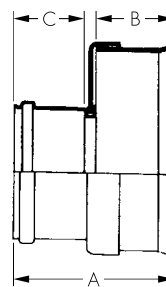

Size (mm)	Code	Dimension (mm)		
		A	B	C
150 × 150	UML21	200	95	90
300 × 225	UML32	240	110	95

Unequal branch (socket)

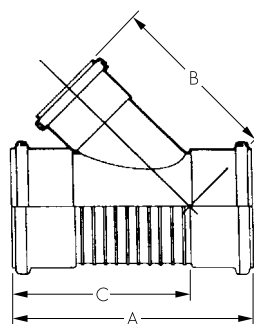

Size (mm)	Code	Angle	Dimension (mm)		
			A	B	C
150 × 110	UMY10Q	45	316	232	236
150 × 110	UMY12Q	87½	313	170	130†
225 × 110	UMY20*	45	370	300	300
225 × 150	UMY21*	45	440	340	340
300 × 110	UMY30	45	520	375	425
300 × 150	UMY31	45	590	425	460
300 × 225	UMY32	45	700	520	480

*injection moulded fittings

†intended for use in back drop manholes

End cap (push fit over pipe)

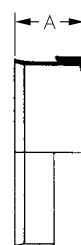

Size (mm)	Code	Dimension A (mm)
150	UMK22	170
225	UMK21	190
300	UMK31	110

Adaptor
twinwall or solid-wall PVC-U to clayware pipe

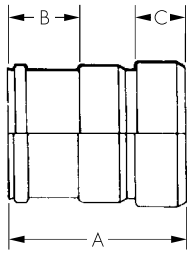

Size (mm)	Code	Dimension (mm)		
		A	B	C
150	UMA45	230	90	60

Adaptor (socket/spigot)
twinwall pipe to solid-wall PVC-U socket (BS 4660/BS 5481)

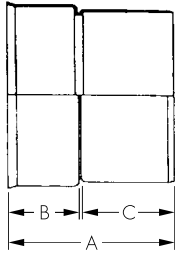

Size (mm)	Code	Dimension (mm)		
		A	B	C
150 x 160	UMA17	160	71	82
225 x 250	UMA27	240	94	134
300 x 315	UMA37	265	110	144

Adaptor (double socket)
twinwall to solid-wall PVC-U pipe



Size (mm)	Code	Dimension (mm)		
		A	B	C
225 x 250	UMA28	240	94	110
300 x 315	UMA38	270	110	125

Pipe seal
for twinwall pipe

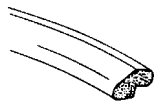

Size (mm)	Code
150	UMR11
225	UMR21
300	UMR31

Pipe seal
for connection to solid-wall PVC-U pipe and PVC-U spigotend fittings

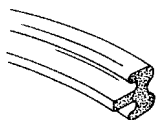

Size (mm)	Code
150	SR61T (seal)
150	SNC6 (seal retaining cap)

2 Delivery and site handling

2.1 Handling, storage and transportation should be in accordance with BS 5955 : Part 6 : 1980.

2.2 When long-term storage is envisaged, Quantum twinwall pipes and fittings must be protected from direct sunlight.

3 General

3.1 Marley Quantum Highway 150 mm, 225 mm and 300 mm Surface Water Drainage Pipes and Fittings have been assessed for use underground for the conveyance of surface water.

3.2 This Detail Sheet does not cover use of the pipe for domestic sewage, combined sewerage systems or untreated trade effluent.

4 Strength

The product has adequate strength to resist loads associated with installation and with subsequent use in the situations defined in section 9 of this Certificate.

5 Performance of joints

The joints are satisfactory and will remain watertight under normal service conditions of pipe deformation, side or vertical displacement, pipeline deflection and thermal movement.

6 Flow characteristics

6.1 The pipes will have the normal flow characteristics associated with PVC-U smooth bore underground drain pipe to BS EN 1401-1 : 1998.

6.2 Full-bore velocities are given in Table 3. The values are based on the Colebrook-White Equation. An appropriate value of roughness coefficient should be selected when designing the drainage system. BS 8005 : Part 1 : 1987 recommends minimum velocities of 0.75 ms⁻¹ to maintain self-cleansing conditions. The highlighted figures in Table 3, therefore, do not reflect recommended conditions.

7 Resistance of chemicals

The pipes and fittings will be unaffected by those types and quantities of chemicals which are likely to be found in surface water drainage pipes and fittings. Details of the chemical resistance of PVC-U is given in CP 312 : Part 1 : 1973.

8 Durability

In the opinion of the BBA, no significant deterioration of the system will take place when the product is installed in accordance with section 9, and installations will have a life in excess of 50 years.

9 Practicability of installation

The pipes and fittings are installed easily using traditional drain-laying methods. The lengths in which the pipes are available and their lightness in weight is a significant advantage in handling and installation. Jointing of the pipes is achieved easily.

10 Water jetting and rodding

Drains and sewers incorporating the product can be maintained using jetting equipment, or rodded using conventional flexible drain rods in accordance with the manufacturer's recommendations. Toothed cutters as used with some mechanical cleaning systems could damage the pipe and should not be used.

Table 3 Full-bore discharges and velocities

Pipe internal diameter = 148.0 mm

Gradient	Roughness R (mm)					
	R = 0.06		R = 0.60		R = 1.50	
	Velocity ms ⁻¹	Flow ls ⁻¹	Velocity ms ⁻¹	Flow ls ⁻¹	Velocity ms ⁻¹	Flow ls ⁻¹
1.0	13.35	229.71	10.07	173.30	8.73	150.13
10.0	4.14	71.16	3.18	54.63	2.76	47.40
20.0	2.89	49.77	2.24	38.55	1.95	33.49
30.0	2.34	40.32	1.83	31.43	1.59	27.33
40.0	2.02	34.70	1.58	27.19	1.37	23.65
50.0	1.79	30.87	1.41	24.29	1.23	21.14
60.0	1.63	28.05	1.29	22.16	1.12	19.29
70.0	1.50	25.87	1.19	20.49	1.04	17.85
80.0	1.40	24.11	1.11	19.16	0.97	16.69
90.0	1.32	22.65	1.05	18.05	0.91	15.73
100.0	1.25	21.42	0.99	17.11	0.87	14.92
120.0	1.13	19.45	0.91	15.60	0.79	13.61
140.0	1.04	17.91	0.84	14.42	0.73	12.59
160.0	0.97	16.68	0.78	13.48	0.68	11.78
180.0	0.91	15.66	0.74	12.69	0.64	11.10
200.0	0.86	14.80	0.70	12.03	0.61	10.52
250.0	0.76	13.13	0.62	10.73	0.55	9.40
300.0	0.69	11.90	0.57	9.78	0.50	8.57
400.0	0.59	10.19	0.49	8.44	0.43	7.41
500.0	0.52	9.03	0.44	7.53	0.38	6.62
600.0	0.48	8.17	0.40	6.85	0.35	6.03
700.0	0.44	7.51	0.37	6.33	0.32	5.58
800.0	0.41	6.98	0.34	5.91	0.30	5.21
900.0	0.38	6.55	0.32	5.56	0.29	4.91
1000.0	0.36	6.18	0.31	5.26	0.27	4.65

Pipe internal diameter = 230.0 mm

Gradient	Roughness R (mm)					
	R = 0.06		R = 0.60		R = 1.50	
	Velocity ms ⁻¹	Flow ls ⁻¹	Velocity ms ⁻¹	Flow ls ⁻¹	Velocity ms ⁻¹	Flow ls ⁻¹
1.0	17.49	726.80	13.38	555.72	11.69	485.85
10.0	5.44	226.14	4.22	175.31	3.69	153.47
20.0	3.81	158.50	2.98	123.78	2.61	108.45
30.0	3.10	128.59	2.43	100.96	2.13	88.50
40.0	2.67	110.79	2.10	87.35	1.84	76.61
50.0	2.37	98.67	1.88	78.07	1.65	68.50
60.0	2.16	89.73	1.71	71.21	1.50	62.51
70.0	1.99	82.79	1.59	65.89	1.39	57.85
80.0	1.86	77.21	1.48	61.59	1.30	54.10
90.0	1.75	72.59	1.40	58.04	1.23	50.99
100.0	1.65	68.68	1.32	55.03	1.16	48.36
120.0	1.50	62.40	1.21	50.18	1.06	44.13
140.0	1.38	57.53	1.12	46.42	0.98	40.84
160.0	1.29	53.61	1.04	43.38	0.92	38.18
180.0	1.21	50.37	0.98	40.87	0.87	35.98
200.0	1.15	47.64	0.93	38.74	0.82	34.13
250.0	1.02	42.31	0.83	34.59	0.73	30.50
300.0	0.92	38.39	0.76	31.53	0.67	27.82
400.0	0.79	32.91	0.66	27.23	0.58	24.06
500.0	0.70	29.19	0.58	24.30	0.52	21.50
600.0	0.64	26.46	0.53	22.14	0.47	19.60
700.0	0.59	24.35	0.49	20.46	0.44	18.13
800.0	0.55	22.65	0.46	19.10	0.41	16.94
900.0	0.51	21.25	0.43	17.98	0.38	15.96
1000.0	0.48	20.07	0.41	17.03	0.36	15.13

Pipe internal diameter = 302.0 mm

Gradient	Roughness R (mm)					
	R = 0.06		R = 0.60		R = 1.50	
	Velocity ms ⁻¹	Flow ls ⁻¹	Velocity ms ⁻¹	Flow ls ⁻¹	Velocity ms ⁻¹	Flow ls ⁻¹
1.0	20.64	1478.58	15.90	1139.28	13.98	1001.15
10.0	6.44	461.08	5.02	359.54	4.42	316.30
20.0	4.52	323.53	3.54	253.92	3.12	223.53
30.0	3.67	262.69	2.89	207.13	2.55	182.43
40.0	3.16	226.47	2.50	179.24	2.20	157.93
50.0	2.82	201.79	2.24	160.21	1.97	141.21
60.0	2.56	183.59	2.04	146.16	1.80	128.87
70.0	2.37	169.46	1.89	135.24	1.67	119.28
80.0	2.21	158.08	1.77	126.44	1.56	111.55
90.0	2.08	148.67	1.66	119.15	1.47	105.15
100.0	1.96	140.71	1.58	112.99	1.39	99.73
120.0	1.79	127.91	1.44	103.05	1.27	91.00
140.0	1.65	117.98	1.33	95.33	1.18	84.22
160.0	1.54	109.98	1.24	89.11	1.10	78.75
180.0	1.44	103.37	1.17	83.96	1.04	74.23
200.0	1.37	97.79	1.11	79.60	0.98	70.40
250.0	1.21	86.91	0.99	71.09	0.88	62.92
300.0	1.10	78.90	0.90	64.81	0.80	57.40
400.0	0.95	67.71	0.78	56.00	0.69	49.66
500.0	0.84	60.10	0.70	49.99	0.62	44.37
600.0	0.76	54.51	0.64	45.55	0.56	40.47
700.0	0.70	50.19	0.59	42.11	0.52	37.44
800.0	0.65	46.71	0.55	39.33	0.49	34.99
900.0	0.61	43.83	0.52	37.03	0.46	32.97
1000.0	0.58	41.41	0.49	35.08	0.44	31.26

Installation

11 Procedure

11.1 Installation must be in accordance with the manufacturer's brochure, BS 5955 : Part 6 : 1980, BS 8005 : Part 1 : 1987, BS 8301 : 1985, BS EN 1610 : 1998, and BS EN 752 : Parts 1 to 3, when appropriate.

11.2 Pipes are cut easily using conventional hand tools, and should be cut square and centrally between the corrugations.

11.3 A rubber sealing ring is fitted externally to the first corrugation in the pipe. The inside of the socket, the seal and the pipe are lubricated and the pipe pushed fully home. The lubricant is supplied by the manufacturer.

11.4 Quantum Highway twinwall pipes and fittings must be adequately protected against damage from site construction traffic.

Technical Investigations

The following is a summary of the technical investigations carried out on Marley Quantum Highway 150 mm, 225 mm and 300 mm Surface Water Drainage Pipes and Fittings.

12 Tests

The following tests were carried out:

Pipes

impact strength at 0°C to BS 4962 : 1989, Appendix E, with modified striker of 1.0 kg mass and 50 mm diameter
specific tangential extrapolated stiffness to BS 4962 : 1989, Appendix B
dimensional accuracy
ease of jointing
resistance to penetration of simulated sharp aggregate
tightness of joints to 0.5 bar positive pressure and 0.5 bar negative pressure and airtightness at 40 mm water gauge
Vicat softening point to BS 2782 : Part 1
box loading test (50 kN load with 0.6 m cover, 100 kN load with 0.9 m cover)
stiffness

Fittings

dimensional accuracy
drop strength to BS 5481 : Appendix D : 1977(1989)
short-term ring stiffness (STIS) to ISO/TC 138/WG11 : method A
flexibility of fabricated fittings to draft pr EN (document 15SN 1269E : June 1994)

Joints

effect of combined temperature and external load to WIS (IGN No 4-31-05, Appendix F
watertightness of joints to 0.5 bar positive pressure and 0.5 bar negative pressure when the pipe is subjected to a 15% distortion and the socket a 10% distortion and also when subjected to 3° angular deflection
insertion force (ease of jointing)
dimensional accuracy of pipe, fittings and ring seal.

13 Other investigations

13.1 An examination was made of data relating to:
chemical
flow capacity
practicability of installation
material properties
resistance to rodding.

13.2 Visits to sites in progress were carried out to assess the practicability of installation.

13.3 The manufacturing process was examined, including the methods adopted for quality control, and details were obtained of the quality and composition of the materials used.

Bibliography

BS 2782 : 1970 *Methods of testing plastics*
Part 1 : Method 120A : 1976(1983)
Determination of the Vicat softening temperature of thermoplastics

BS 4962 : 1989 (prior to 1996 amendment)
Specification for plastics pipes and fittings for use as subsoil field drains

BS 5955 *Plastics pipework (thermoplastics materials)*
Part 6 : 1980 *Code of practice for the installation of unplasticized PVC pipework for gravity drains and sewers*

BS 8005 : 1987 *Sewerage*
Part 1 : 1987 *Guide to new sewerage construction*

BS 8301 : 1985 *Code of practice for building drainage*

BS EN 681 *Elastomeric seals. Material requirements for pipe joint seals used in water and drainage applications*

BS EN 681-1 : 1996 *Vulcanized rubber*

BS EN 752 *Drains and sewer systems outside buildings*
Part 1 : 1996 *Generalities and definitions*
Part 2 : 1997 *Performance requirements*
Part 3 : 1997 *Planning*

BS EN 1401 *Plastics piping systems for non-pressure underground drainage and sewerage — Unplasticized poly (vinyl chloride) (PVC-U)*
BS EN 1401-1 : 1998 *Specifications for pipes, fittings and the system*

BS EN 1610 : 1998 *Construction and testing of drains and sewers*

CP 312 *Code of practice for plastics pipework (thermoplastics material)*
Part 1 : 1973 *General principles and choice of material*



On behalf of the British Board of Agrément

Date of issue: 31st March 1998

A handwritten signature in black ink, appearing to read 'P. C. Newson'.

Director