

Web Dynamics Ltd

Moss Lane
Blackrod
Bolton
Lancashire BL6 5JB

Tel: 01204 695666 Fax: 01204 695333
e-mail: thinsulex@webdynamics.co.uk
website: www.webdynamics.co.uk



Agrément Certificate
No 06/4379

MULTIFOIL INSULATION**PRODUCT SHEET 1 — THINSULEX SILVER****PRODUCT SCOPE AND SUMMARY OF CERTIFICATE**

This Certificate relates to Thinsulex Silver, a reflective insulation material for use in pitched roofs.

THIS CERTIFICATE INCLUDES:

- factors relating to compliance with UK Building Regulations where applicable
- factors relating to additional non-regulatory information where applicable
- independently verified technical specification
- assessment criteria and technical investigations
- design considerations
- installation guidance
- regular surveillance of production
- formal three-yearly review.

**KEY FACTORS ASSESSED**

Thermal performance — when combined with other types of insulation, the product can contribute in meeting the U value requirement for a roof (see section 4).

Condensation risk — the performance of the product with regard to interstitial and surface condensation has been considered (see section 5).

Behaviour in relation to fire — the roof system using this product can be designed to meet the UK requirements (see section 6).

Durability — the durability of the product is satisfactory and will have a life equivalent to that of the structure in which it is incorporated (see section 11).

The BBA has awarded this Agrément Certificate for Thinsulex Silver to Web Dynamics Ltd as fit for its intended use provided it is installed, used and maintained as set out in this Agrément Certificate.

On behalf of the British Board of Agrément

Date of First issue: 27 October 2006
Date of Second issue: 25 October 2007

Greg Cooper: Chief Executive

The BBA is a UKAS accredited certification body — Number 113. The schedule of the current scope of accreditation for product certification is available in pdf format via the UKAS link on the BBA website at www.bbacerts.co.uk

Readers are advised to check the validity and latest issue number of this Agrément Certificate by either referring to the BBA website or contacting the BBA direct.

British Board of Agrément
Bucknalls Lane
Garston, Watford
Herts WD25 9BA

©2007

tel: 01923 665300
fax: 01923 665301
e-mail: mail@bba.star.co.uk
website: www.bbacerts.co.uk

Regulations

In the opinion of the BBA, Thinsulex Silver, if used in accordance with the provisions of this Certificate, will meet or contribute to meeting the relevant requirements of the following Building Regulations:



The Building Regulations 2000 (as amended) (England and Wales)

Requirement:	B3(4)	Internal fire spread (structure)
Comment:		The product will not affect the external fire rating of a tiled or slated roof in which it is installed. See section 6.2 of this Certificate.
Requirement:	C2(c)	Resistance to moisture
Comment:		The product can contribute to a roof meeting this Requirement. See sections 5.1 and 5.8 of this Certificate.
Requirement:	L1(a)(i)	Conservation of fuel and power
Comment:		Roofs incorporating the product can contribute to a building meeting its Target Emission Rate. See sections 4.2 to 4.5 of this Certificate.
Requirement:	Regulation 7	Materials and workmanship
Comment:		The product is acceptable. See section 11 of this Certificate.



The Building (Scotland) Regulations 2004 (as amended)

Regulation:	8	Fitness and durability of materials and workmanship
Regulation:	8(1)	Fitness and durability of materials and workmanship
Comment:		The product can contribute to a construction satisfying this Regulation. See section 11 and the <i>Installation</i> part of this Certificate.
Regulation:	9	Building standards – construction
Standard:	2.2	Separation
Comment:		The product must not penetrate the separating wall junction with the roof to ensure that the fire-resistant integrity of the separating wall is maintained in accordance with clause 2.2.10 ⁽¹⁾ . See section 6.2 of this Certificate.
Standard:	3.15	Condensation
Comment:		The product can contribute to a roof satisfying the requirements of clauses 3.15.1 ⁽¹⁾ to 3.15.5 ⁽¹⁾ and 3.15.7 ⁽¹⁾ of this Standard. See sections 5.1 and 5.9 of this Certificate.
Standard:	6.1 (a)(b)	Carbon dioxide emissions
Standard:	6.2	Building insulation envelope
Comment:		The product can contribute to a roof satisfying the requirements of these Standards, with reference to clauses or parts of 6.1.2 ⁽¹⁾ , 6.1.6 ⁽¹⁾ , 6.2.1 ⁽¹⁾ , 6.2.3 ⁽¹⁾ , 6.2.4 ⁽¹⁾ and 6.2.5 ⁽¹⁾ . See sections 4.2 to 4.5 of this Certificate.
Regulation:	12	Building standards – conversions
Comment:		All comments given for this product under Regulation 9, also apply to this Regulation, with reference to clause 0.12.1 ⁽¹⁾ and Schedule 6 ⁽¹⁾ . (1) Technical Handbook (Domestic).



The Building Regulations (Northern Ireland) 2000 (as amended)

Regulation:	B2	Fitness of materials and workmanship
Comment:		The product is acceptable. See section 11 of this Certificate.
Regulation:	C5	Condensation
Comment:		The product can contribute to a roof satisfying the requirements of this Regulation. See section 5.1 of this Certificate.
Regulation:	E5(b)	External fire spread
Comment:		The product will not affect the external fire rating of a tiled or slated roof in which it is installed. See section 6.2 of this Certificate.
Regulation:	F2(a)(i)	Conservation measures
Regulation:	F3(2)	Target carbon dioxide Emissions Rate
Comment:		The product can contribute to a building satisfying its Target Emission Rate. See sections 4.2 to 4.5 of this Certificate.

Construction (Design and Management) Regulations 2007

Construction (Design and Management) Regulations (Northern Ireland) 2007

Information in this Certificate may assist the client, CDM co-ordinator, designer and contractors to address their obligations under these Regulations.

See section: 2 *Delivery and site handling* (2.2).

Non-regulatory Information

NHBC Standards 2007

NHBC accepts the use of Thinsulex Silver, when installed and used in accordance with this Certificate, in relation to NHBC Standards, Chapter 7.2 *Pitched roofs*, Design Standard 7.2 – D10-D11 *Insulation and control of condensation*.

Zurich Building Guarantee Technical Manual 2007

In the opinion of the BBA, Thinsulex Silver, when installed and used in accordance with this Certificate, satisfies the requirements of the *Zurich Building Guarantee Technical Manual*, Section 4 *Superstructure*, Sub-section *Pitched roofs*, pages 240 to 267.

General

This Certificate relates to Thinsulex Silver and is for use as an insulation above and/or below rafters in tiled or slated pitched roofs designed and constructed in accordance with the relevant clauses of BS 5534 : 2003. The product can also be used in dormer cheeks and dwarf wall applications.

Technical Specification

1 Description

1.1 Thinsulex Silver is an insulation material comprising outer layers of coated metallised film, laminated to a non-woven polypropylene fabric enclosing the core and welded along both long edges. The core of the product consists of five layers of polyester fibre wadding separated by four metallised film layers.

1.2 The product is available in roll form with a width of 1.2 m, 10 m length and 30 mm thickness.

1.3 Ancillary items used with the product are:

- Henkel 'Duck' brand 50 mm duct tape (silver)
- Thinsulex tape, foil-backed tape with acrylic adhesive, width 50 mm, 75 mm or 100 mm⁽¹⁾
- 14 mm staples or nails⁽¹⁾
- vapour control layer⁽¹⁾
- roof tile underlay⁽¹⁾
- pre-treated counter battens, softwood battens and tiling laths⁽¹⁾
- roofing slates or tiles⁽¹⁾
- additional insulation where required⁽¹⁾

(1) Outside the scope of this Certificate.

2 Delivery and site handling

2.1 The product is delivered to site in rolls packed in a protective, branded bag sealed with an end label. Fitting instructions are placed in the bag.

2.2 The rolls should be stored in clean, dry conditions not exposed to sunlight. The product must be protected from being dropped or crushed by objects. Care must be exercised when storing large quantities on site. The product must not be exposed to open flame or other ignition sources and must be stored away from flammable material such as paint and solvents.

2.3 On site, to ensure maximum performance of the product when installed, precautions must be taken to protect it from mud and dirt.

Assessment and Technical Investigations

The following is a summary of the assessment and technical investigations carried out on Thinsulex Silver.

Design Considerations

3 Use

3.1 Thinsulex Silver is a flexible insulation used in conjunction with other insulation materials to reduce the U value (thermal transmittance) in new or existing pitched roofs. When installed under the rafters, the product performs as a vapour control layer in the roof system (see section 5).

3.2 The product is for use in constructions where the ceiling follows the pitch of the roof and encloses a habitable space. The product can also be used in dwarf walls and dormer cheeks.

3.3 Care must be taken to ensure that the product is covered after installation, as it must not be exposed to rain, showers or wind-driven rain.

3.4 Care must be taken to ensure the product does not come into contact with heat sources greater than 80°C.

4 Thermal performance

4.1 Calculations of the thermal transmittance (U value) of specific roof constructions and dwarf walls/dormer cheeks incorporating Thinsulex Silver should be carried out in accordance with BS EN ISO 6946 : 1997 and BRE report (BR 443 : 2006), *Conventions for U-value calculations* using the following values:

- thermal resistance of the insulation including air layers and bridging (for the timber percentages shown in Figure 1) — $1.69 \text{ m}^2\text{KW}^{-1}$
- emissivity of outer layers — 0.16
- for other constructions, a core insulation R value of $0.91 \text{ m}^2\text{KW}^{-1}$ should be used (see section 15.2).

Figure 1 Test roof construction (as described in original issue of BBA Certificate 06/4379 for Thinsulex)

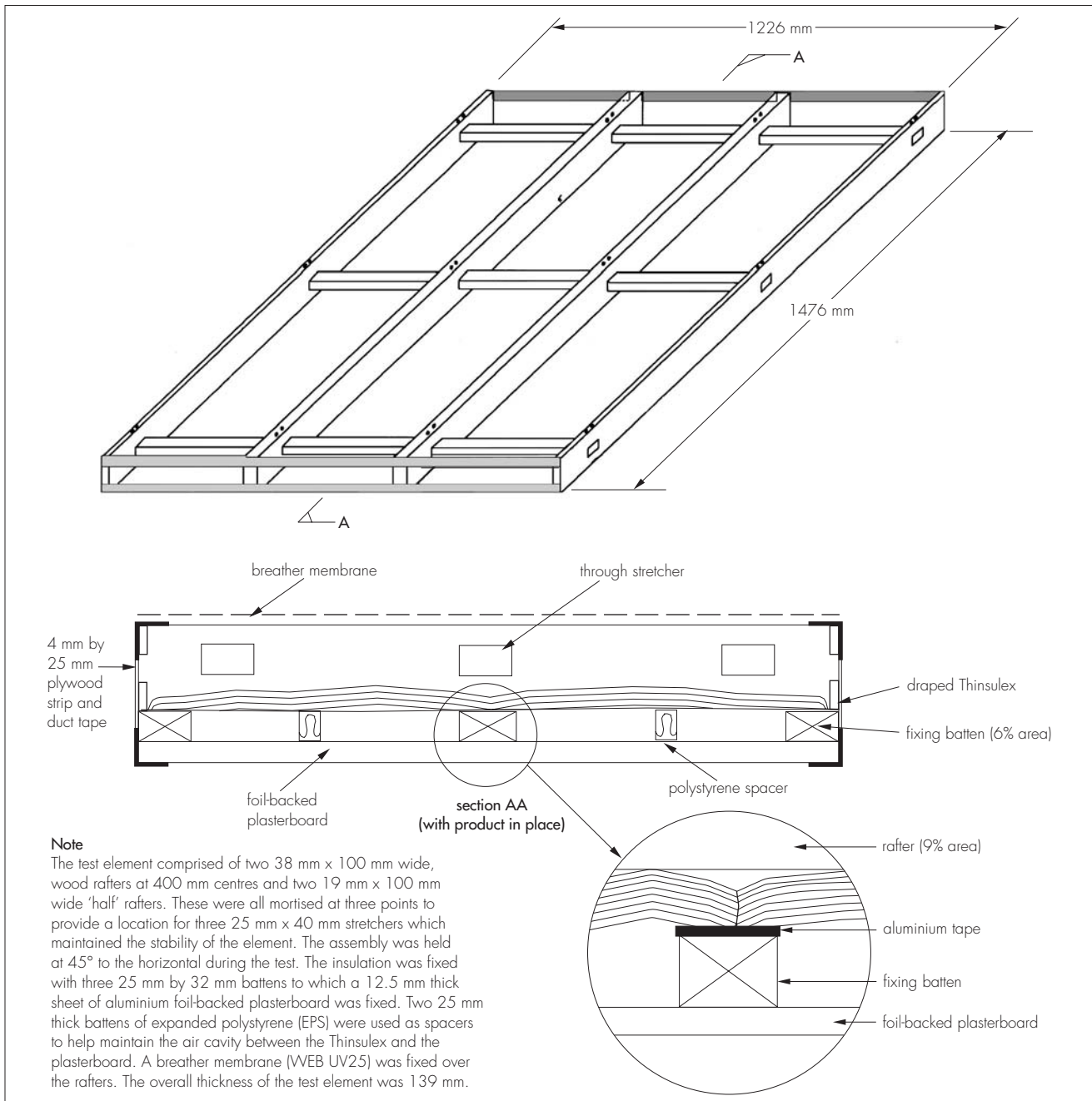



4.2 The ultimate thermal performance of the product will depend on the construction of the roof on which it is installed and the combination of it with other insulation products is necessary to achieve the following design U values:

England and Wales and Northern Ireland

- 0.16 $\text{Wm}^{-2}\text{K}^{-1}$ required for 'notional' dwellings in SAP 2005
- 0.25 $\text{Wm}^{-2}\text{K}^{-1}$ limit average value specified in Approved Document L1A (Table 2) and Technical Booklet F1 (Table 2.2)
- 0.35 $\text{Wm}^{-2}\text{K}^{-1}$ limit for an individual element specified in Approved Document L1A (Table 2) and Technical Booklet F1 (Table 2.2).

Scotland

- 0.16 $\text{Wm}^{-2}\text{K}^{-1}$ for a 'notional' domestic roof required for all fuel packages in Mandatory Standard 6.1, clauses 6.1.6⁽¹⁾ and 6.1.2⁽¹⁾
- 0.20 $\text{Wm}^{-2}\text{K}^{-1}$ maximum average specified in Mandatory Standard 6.2, clause 6.2.1⁽¹⁾
- 0.35 $\text{Wm}^{-2}\text{K}^{-1}$ maximum value for an individual roof element specified in Mandatory Standard 6.2, clause 6.2.1⁽¹⁾
- 0.20 $\text{Wm}^{-2}\text{K}^{-1}$ for extensions as described in Mandatory Standard 6.2, clause 6.2.9⁽¹⁾.

(1) Technical Handbook (Domestic).

4.3 Where a proposed roof U value is higher than the relevant 'notional' value specified in section 4.2, additional energy saving measures will be required in the building envelope and/or services in order to achieve the required overall carbon dioxide emission rate reduction of about 20% in dwellings and 18% to 25% in Scotland.

4.4 Compliance with the guidance referred to in section 4.2 (see also Figure 2) will allow the use of the default psi values from Table 3 of BRE Information Paper IP 1/06 *Assessing the effects of thermal bridging at junctions and around openings* and Table K1 of *The Government's Standard Assessment Procedure for Energy rating of Dwellings* (SAP 2005), in Target Emission Rate calculations to SAP 2005 use 'simplified approach' for Scotland).

4.5 The product can maintain or contribute to maintaining continuity of thermal insulation at junctions between the external wall and other building elements. Guidance in this respect, and on limiting heat loss by air infiltration, can be found in:

England and Wales — *Limiting thermal bridging and air leakage: Robust construction details for dwellings and similar buildings* TSO 2002

Scotland — Accredited Construction Details (Scotland)

Northern Ireland — Accredited Construction Details (version 1.0).

Figure 2 Construction details

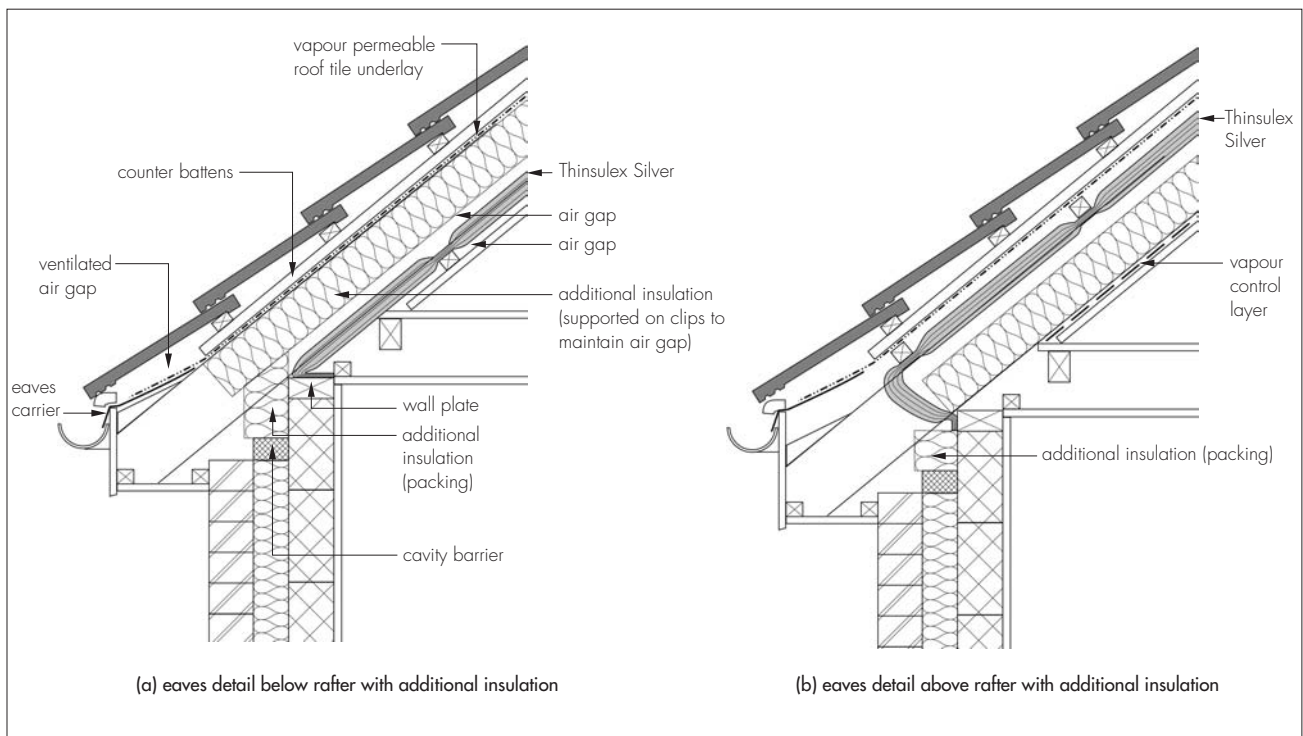

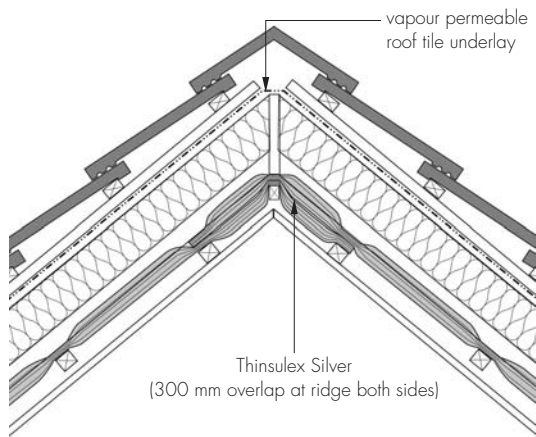

(c) ridge detail below rafter with additional insulation

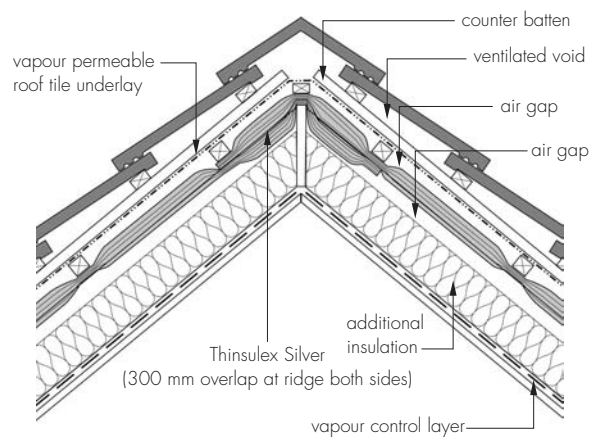

(d) ridge detail above rafter with additional insulation

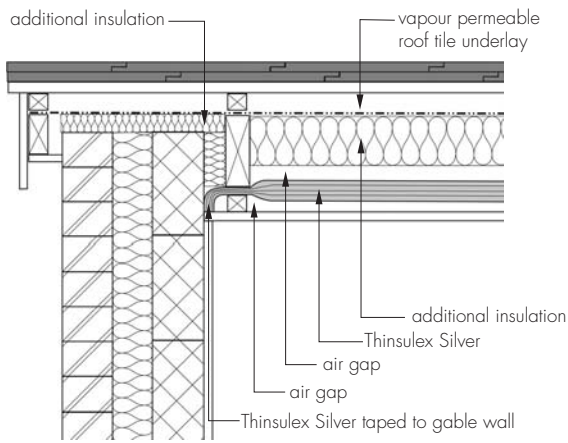

(e) gable detail below rafter with additional insulation

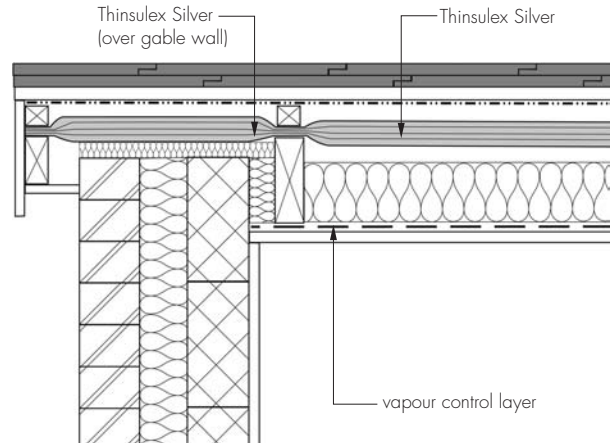

(f) gable detail above rafter with additional insulation

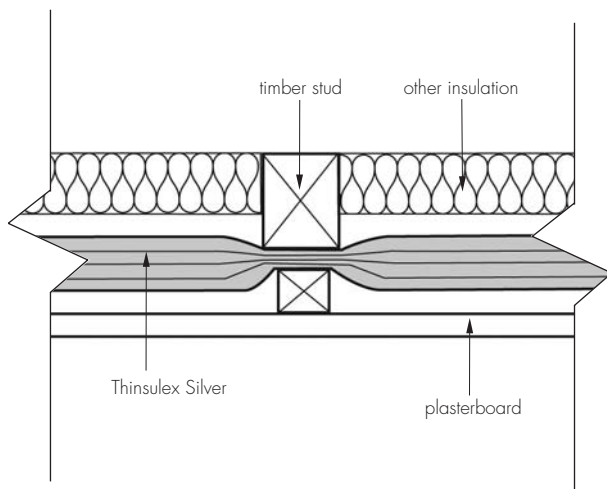

(g) Dwarf wall detail

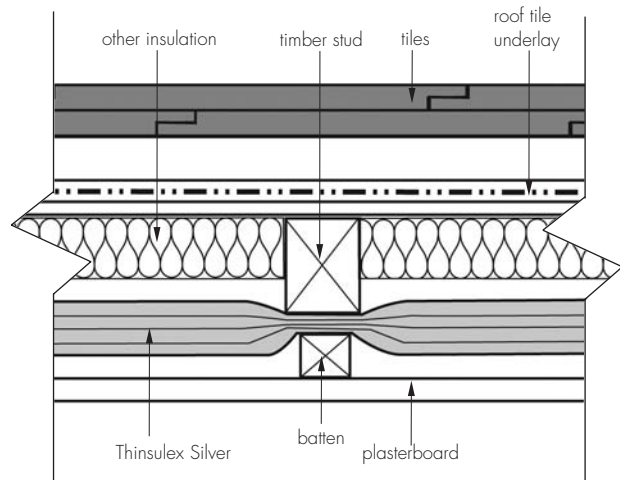

(h) Dormer cheek detail

5 Condensation risk

Interstitial condensation



5.1 Roofs incorporating the product will adequately limit the risk of interstitial condensation when designed and constructed in accordance with BS 5250 : 2002, Section 8.4 and Appendix D.

5.2 The risk of interstitial condensation is greatest when the building is drying out after construction. Guidance on preventing condensation from this and other sources is given in BRE Digest 369 *Interstitial condensation and fabric degradation* and BRE report (BR 262 : 2002) *Thermal insulation: avoiding risks*.

5.3 The product has a high water vapour resistance with a measured value in excess of 1200 MNsg^{-1} .

5.4 When installed in accordance with section 1.3 and in a continuous layer, the product will provide a convection-free envelope of high vapour resistance.

Installation above rafters

5.5 A vapour control layer should be used in conjunction with a suitable vapour permeable roof tile underlay without a ventilated air space.

Installation below rafters

5.6 The product will perform as a vapour control layer and should be used in conjunction with a vapour permeable roof tile underlay.

5.7 In all cases, where high vapour resistance roof tile underlays are used, ventilation to the air space should be in accordance with the recommendations of BS 5250 : 2002 or relevant BBA Certificate for the roof tile underlay. When installed in conjunction with other insulation materials, the water vapour resistance and installation instructions of the additional insulation should be taken into consideration.

Surface condensation



5.8 Roofs will adequately limit the risk of surface condensation when the thermal transmittance (U value) does not exceed $0.35 \text{ Wm}^{-2}\text{K}^{-1}$ at any point and the junctions with walls are designed in accordance with the relevant requirements of *Limiting thermal bridging and air leakage: Robust construction details for dwellings and similar buildings*, TSO 2002 or BRE Information Paper IP 1/06.



5.9 Roofs will adequately limit the risk of surface condensation when the thermal transmittance (U value) does not exceed $1.2 \text{ Wm}^{-2}\text{K}^{-1}$ at any point. Guidance may be obtained from Section 8 of BS 5250 : 2002 and BRE Report (BR 262 : 2002).

6 Behaviour in relation to fire

6.1 When installed with an internal lining board, eg 12.5 mm thick plasterboard, the insulation will be contained between the roof and internal lining board, until one is destroyed. Therefore, the insulation will not contribute to the development stages of a fire or present a smoke or toxic hazard.



6.2 The insulation must not be carried over junctions between roofs and walls required to provide a minimum period of fire resistance. The continuity of fire resistance must be maintained, for example as described in:

England and Wales — Approved Document B, Volume 1, Sections 5.11 to 5.12

Scotland — Mandatory Standard 2.2, clause 2.2.10⁽¹⁾

(1) Technical Handbook (Domestic).

Northern Ireland — Technical Booklet E, paragraph 3.21.

6.3 The use of the product will not affect the fire rating obtained by tiled or slated roofs when evaluated by assessment or test to BS 476-3 : 1958.

6.4 When installed with other additional insulation materials, the fire properties of these materials must be taken into consideration.

7 Proximity of flues and appliances

When the product is installed in close proximity to certain flue pipes and/or heat-producing appliances, for buildings subject to national Building Regulations the relevant provisions and guidance given below should be met:

England and Wales — Approved Document J

Scotland — Mandatory Standard 3.19

Northern Ireland — Technical Booklet L.

8 Air leakage

8.1 The insulation was tested to BS EN 12114 : 2000 with positive pressure of 50 Pa and 100 Pa. The leakage rate was $0.19 \text{ m}^3\text{h}^{-1}\text{m}^{-2}$ and practically zero respectively.

8.2 When the product is used as a vapour control layer and an air barrier, the airtightness of the system is reliant on the careful sealing of the insulation and is dependent on maintaining the integrity of seal throughout. In addition to sealing at all joints, the insulation must be suitably sealed at the perimeter and all penetrations. Details of sealing at eaves, ridges, hips, valleys and penetrations must be in accordance with the Certificate holder's instructions.

8.3 The airtightness of the building will also be dependent on the performance of the other building elements. Provided these also incorporate appropriate design details and building techniques, air infiltration through the building fabric should be minimal and the building reasonably airtight.

9 De-rating of electrical cables

As with other insulation products, it may be necessary in some cases to de-rate electrical cables buried in insulation. In BS 7671 : 2000 it is suggested that where wiring is completely surrounded by insulation, it may need to be de-rated to as low as half its free air current carrying capacity. Guidance should be sought from a qualified electrician.

10 Maintenance and repair

Once installed, the product does not require any maintenance. Small holes, rips or punctures in the outer layers should be repaired with either Henkel 'Duck' brand duct tape (silver) or with Thinsulex tape.

11 Durability



The product is rot-proof, does not tear easily and when installed as specified, will have a life equivalent to that of the roof structure in which it is incorporated.

Installation

12 General

12.1 Installation of Thinsulex Silver and additional insulation products should be in accordance with the Certificate holder's instructions and current good building practice.

12.2 During construction, care must be taken to ensure the product is not damaged during installation. Should damage occur by tearing, the product should be repaired by covering the holes with tape (see also section 13.14) or replaced.

12.3 The product is attached to the rafters by using staples or nails of at least 14 mm length. Double-sided tape and glue can also be used.

12.4 The product must have overlap joints of at least 50 mm and be taped along the entire length of the joint with tape (see section 1.3).

12.5 When the product is cut to fit around openings, eg the roof perimeter, care should be taken to minimise gaps.

12.6 The product can be cut easily by using sharp scissors or a knife.

12.7 Any exposed cut edges of the product should be sealed with a suitable adhesive tape.

13 Procedure

Above rafters installation

13.1 Installation starts from eaves and the insulation is unrolled parallel to the eaves.

13.2 As the product is unrolled across the rafters it is fixed using nails or staples of at least 14 mm length.

13.3 The next roll must overlap the preceding layer by at least 50 mm, and the overlap should be sealed along the entire length using tape (see section 1.3).

13.4 The product should be permanently fixed in place using wooden battens parallel to the rafters, held in place with nails.

13.5 When the top layer has been battened, any excess material may be cut by running a sharp knife along the edge of the batten.

13.6 A breathable roofing membrane (ie roof tile underlay) should be installed on the counter battens and tiling battens attached perpendicular to the rafters.

13.7 Roof tiles or slates are installed in accordance with BS 5534 : 2003.

13.8 When applying roof tiles or slates to a warm roof construction the recommendations of the tile/slate manufacturer should be followed.

Below rafters installation

13.9 Installation starts from the ridge with the product being unrolled parallel to the eaves.

13.10 As the product is unrolled across the rafters, it is fixed in place using glue, double-sided tape, nails or staples of at least 14 mm depth.

13.11 The next roll must overlap the preceding layer by at least 50 mm, and the overlap should be sealed along the entire length using tape (see section 1.3).

13.12 The product should be permanently held in place using wooden battens fixed with nails. Battens may run either parallel or perpendicular to the rafters.

13.13 When the bottom layer has been battened, any excess material may be cut by running a sharp knife along the edge of the batten.

13.14 Any exposed cut edges of the product should be sealed with a suitable adhesive tape. Any tears or holes in the outer layer should be repaired with heat-reflective tape.

13.15 A foil-backed plasterboard is fixed to the battens. The batten size should be at least 32 mm by 25 mm, with the fixings at either 150 mm spacing for nails or 230 mm for screws. This batten size should be sufficient to ensure a 20 mm air gap between the product and the plasterboard.

Additional insulation

13.16 When used with other additional insulation materials, care should be taken to ensure that all gaps are maintained in accordance with the manufacturer's instructions for their products, and advice should be sought from the Certificate holder.

13.17 When the product is installed below the rafters, mineral wool products can be placed directly on top of the product between the rafters without an air space. When the product is installed above the rafters, mineral wool can rest on the vapour control layer and plasterboard without an air space.

13.18 Rigid polyurethane (PUR) products can be placed with a 20 mm gap above and below the insulation between rafters. Suitable fixings such as wooden battens nailed to the sides of the rafters or clips should be used in accordance with the manufacturer's instructions.

Technical Investigations

14 Tests

Tests were carried out on Thinsulex Silver to determine the emissivity and durability of the outer foil.

15 Investigations

15.1 A re-examination was made of the data on which the first issue of Certificate No 06/4379 was based; the original conclusions remain valid.

15.2 Thermal transmittance (U values) were measured according to BS EN ISO 8990 : 1996 with 30 mm thickness of Thinsulex, installed in the representative roof section shown in Figure 1. The U value of the roof structure with Thinsulex installed above rafters was $0.53 \text{ Wm}^{-1}\text{K}^{-1}$ and $0.29 \text{ Wm}^{-2}\text{K}^{-1}$ where Thinsulex was installed under and above the rafters. The emissivity of the outer layer was 0.4.

15.3 An assessment of the risk of interstitial condensation in typical constructions was made.

Bibliography

- BS 476-3 : 1958 *Fire tests on building materials and structures — External fire exposure roof test*
- BS 5250 : 2002 *Code of practice for control of condensation in buildings*
- BS 5534 : 2003 *Code of practice for slating and tiling (including shingles)*
- BS 7671 : 2001 *Requirements for electrical installations. IEE Wiring Regulations. Sixteenth Edition*
- BS EN 12114 : 2000 *Thermal performance of buildings — Air permeability of building components and building elements — Laboratory test method*
- BS EN ISO 6946 : 1997 *Building components and building elements — Thermal resistance and thermal transmittance — Calculation method*
- BS EN ISO : 8990 : 1996 *Thermal insulation — Determination of steady-state thermal transmission properties — Calibrated and guarded hot box*

16 Conditions

16.1 This Certificate:

- relates only to the product/system that is named and described on the front page
- is granted only to the company, firm or person named on the front page — no other company, firm or person may hold or claim any entitlement to this Certificate
- is valid only within the UK
- has to be read, considered and used as a whole document — it may be misleading and will be incomplete to be selective
- is copyright of the BBA
- is subject to English law.

16.2 References in this Certificate to any Act of Parliament, Statutory Instrument, Directive or Regulation of the European Union, British, European or International Standard, Code of Practice, manufacturers' instructions or similar publication, are references to such publication in the form in which it was current at the date of this Certificate.

16.3 This Certificate will remain valid for an unlimited period provided that the product/system and the manufacture and/or fabrication including all related and relevant processes thereof:

- are maintained at or above the levels which have been assessed and found to be satisfactory by the BBA
- continue to be checked as and when deemed appropriate by the BBA under arrangements that it will determine
- are reviewed by the BBA as and when it considers appropriate.

16.4 In granting this Certificate, the BBA is not responsible for:

- the presence or absence of any patent, intellectual property or similar rights subsisting in the product/system or any other product/system
- the right of the Certificate holder to manufacture, supply, install, maintain or market the product/system
- individual installations of the product/system, including the nature, design, methods and workmanship of or related to the installation
- the actual works in which the product/system is installed, used and maintained, including the nature, design, methods and workmanship of such works.

16.5 Any information relating to the manufacture, supply, installation, use and maintenance of this product/system which is contained or referred to in this Certificate is the minimum required to be met when the product/system is manufactured, supplied, installed, used and maintained. It does not purport in any way to restate the requirements of the Health & Safety at Work etc Act 1974, or of any other statutory, common law or other duty which may exist at the date of this Certificate; nor is conformity with such information to be taken as satisfying the requirements of the 1974 Act or of any statutory, common law or other duty of care. In granting this Certificate, the BBA does not accept responsibility to any person or body for any loss or damage, including personal injury, arising as a direct or indirect result of the manufacture, supply, installation, use and maintenance of this product/system.

Web Dynamics Ltd

Moss Lane
Blackrod
Bolton
Lancashire BL6 5JB

Tel: 01204 695666 Fax: 01204 695333
e-mail: thinsulex@webdynamics.co.uk
website: www.webdynamics.co.uk



Agrément Certificate
No 06/4379

MULTIFOIL INSULATION**PRODUCT SHEET 2 — RAFTERFIT****PRODUCT SCOPE AND SUMMARY OF CERTIFICATE**

This Certificate relates to Rafterfit, a reflective insulation material for use in pitched roofs.

THIS CERTIFICATE INCLUDES:

- factors relating to compliance with UK Building Regulations where applicable
- factors relating to additional non-regulatory information where applicable
- independently verified technical specification
- assessment criteria and technical investigations
- design considerations
- installation guidance
- regular surveillance of production
- formal three-yearly review.

**KEY FACTORS ASSESSED**

Thermal performance — when combined with other types of insulation, the product can contribute in meeting the U value requirement for a roof (see section 4).

Condensation risk — the performance of the product with regard to interstitial and surface condensation has been considered (see section 5).

Behaviour in relation to fire — the roof system using this product can be designed to meet the UK requirements (see section 6).

Durability — the durability of the product is satisfactory and will have a life equivalent to that of the structure in which it is incorporated (see section 11).

The BBA has awarded this Agrément Certificate for Rafterfit to Web Dynamics Ltd as fit for its intended use provided it is installed, used and maintained as set out in this Agrément Certificate.

On behalf of the British Board of Agrément

Greg Cooper: Chief Executive

Date of First issue: 25 October 2007

The BBA is a UKAS accredited certification body — Number 113. The schedule of the current scope of accreditation for product certification is available in pdf format via the UKAS link on the BBA website at www.bbacerts.co.uk

Readers are advised to check the validity and latest issue number of this Agrément Certificate by either referring to the BBA website or contacting the BBA direct.

British Board of Agrément
Bucknalls Lane
Garston, Watford
Herts WD25 9BA

tel: 01923 665300
fax: 01923 665301
e-mail: mail@bba.star.co.uk
website: www.bbacerts.co.uk

©2007

Regulations

In the opinion of the BBA, Rafterfit, if used in accordance with the provisions of this Certificate, will meet or contribute to meeting the relevant requirements of the following Building Regulations:



The Building Regulations 2000 (as amended) (England and Wales)

Requirement:	B3(4)	Internal fire spread (structure)
Comment:		The product will not affect the external fire rating of a tiled or slated roof in which it is installed. See section 6.2 of this Certificate.
Requirement:	C2(c)	Resistance to moisture
Comment:		The product can contribute to a roof meeting this Requirement. See sections 5.1 and 5.6 of this Certificate.
Requirement:	L1(a)(i)	Conservation of fuel and power
Comment:		Roofs incorporating the product can contribute to a building meeting its Target Emission Rate. See sections 4.2 to 4.5 of this Certificate.
Requirement:	Regulation 7	Materials and workmanship
Comment:		The product is acceptable. See section 11 of this Certificate.



The Building (Scotland) Regulations 2004 (as amended)

Regulation:	8	Fitness and durability of materials and workmanship
Regulation:	8(1)	Fitness and durability of materials and workmanship
Comment:		The product can contribute to a construction satisfying this Regulation. See section 11 and the <i>Installation</i> part of this Certificate.
Regulation:	9	Building standards – construction
Standard:	2.2	Separation
Comment:		The product must not penetrate the separating wall junction with the roof to ensure that the fire-resistant integrity of the separating wall is maintained in accordance with clause 2.2.10 ⁽¹⁾ . See section 6.2 of this Certificate.
Standard:	3.15	Condensation
Comment:		The product can contribute to a roof satisfying the requirements of clauses 3.15.1 ⁽¹⁾ to 3.15.5 ⁽¹⁾ and 3.15.7 ⁽¹⁾ of this Standard. See sections 5.1 and 5.7 of this Certificate.
Standard:	6.1 (a)(b)	Carbon dioxide emissions
Standard:	6.2	Building insulation envelope
Comment:		The product can contribute to a roof satisfying the requirements of these Standards, with reference to clauses or parts of 6.1.2 ⁽¹⁾ , 6.1.6 ⁽¹⁾ , 6.2.1 ⁽¹⁾ , 6.2.3 ⁽¹⁾ , 6.2.4 ⁽¹⁾ and 6.2.5 ⁽¹⁾ . See sections 4.2 to 4.5 of this Certificate.
Regulation:	12	Building standards – conversions
Comment:		All comments given for this product under Regulation 9, also apply to this Regulation, with reference to clause 0.12.1 ⁽¹⁾ and Schedule 6 ⁽¹⁾ . (1) Technical Handbook (Domestic).



The Building Regulations (Northern Ireland) 2000 (as amended)

Regulation:	B2	Fitness of materials and workmanship
Comment:		The product is acceptable. See section 11 of this Certificate.
Regulation:	C5	Condensation
Comment:		The product can contribute to a roof satisfying the requirements of this Regulation. See section 5.1 of this Certificate.
Regulation:	E5(b)	External fire spread
Comment:		The product will not affect the external fire rating of a tiled or slated roof in which it is installed. See section 6.2 of this Certificate.
Regulation:	F2(a)(i)	Conservation measures
Regulation:	F3(2)	Target carbon dioxide Emissions Rate
Comment:		The product can contribute to a building satisfying its Target Emission Rate. See sections 4.2 to 4.5 of this Certificate.

Construction (Design and Management) Regulations 2007

Construction (Design and Management) Regulations (Northern Ireland) 2007

Information in this Certificate may assist the client, CDM co-ordinator, designer and contractors to address their obligations under these Regulations.

See section: 2 *Delivery and site handling* (2.2).

Non-regulatory Information

NHBC Standards 2007

NHBC accepts the use of Rafterfit, when installed and used in accordance with this Certificate, in relation to NHBC Standards, Chapter 7.2 *Pitched roofs*, Design Standard 7.2 – D10-D11 *Insulation and control of condensation*.

Zurich Building Guarantee Technical Manual 2007

In the opinion of the BBA, Rafterfit, when installed and used in accordance with this Certificate, satisfies the requirements of the *Zurich Building Guarantee Technical Manual*, Section 4 *Superstructure*, Sub-section *Pitched roofs*, pages 240 to 267.

General

This Certificate relates to Rafterfit and is for use as an insulation between rafters in tiled or slated pitched roofs designed and constructed in accordance with the relevant clauses of BS 5534 : 2003. The product can also be used in dormer cheeks and dwarf wall applications.

Technical Specification

1 Description

1.1 Rafterfit is an insulation material comprising outer layers of coated metallised film, laminated to a non-woven polypropylene fabric enclosing the core and welded along both long edges. The core of the product consists of five layers of polyester fibre wadding separated by four metallised film layers and it is secured together with two welds separated by 420 mm. The outer layers continue a further 56 mm beyond the weld on either side to form two wings. A further weld between the two outer layers is located at the edges (see Figure 1).

Figure 1 Rafterfit cross-section

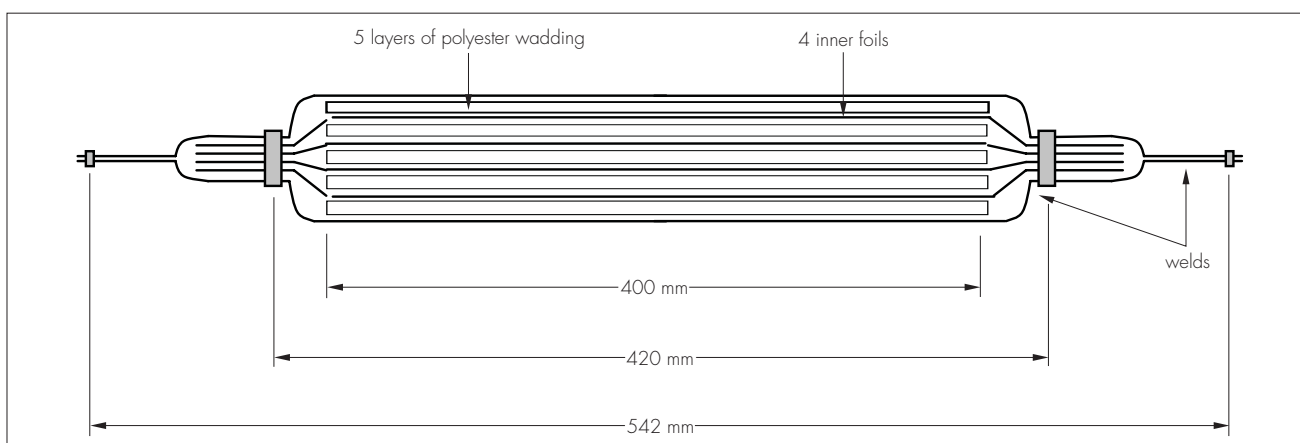

1.2 The product is available in roll form with a width of 550 mm, 10 m length and 30 mm thickness.

1.3 Ancillary items used with the product are:

- Henkel 'Duck' brand 50 mm duct tape (silver)
- Thinsulex tape, foil-backed tape with acrylic adhesive, width 50 mm, 75 mm or 100 mm⁽¹⁾
- 14 mm staples or nails⁽¹⁾
- vapour control layer⁽¹⁾
- roof tile underlay⁽¹⁾
- pre-treated counter battens, softwood battens and tiling laths⁽¹⁾
- roofing slates or tiles⁽¹⁾
- additional insulation where required⁽¹⁾

(1) Outside the scope of this Certificate.

2 Delivery and site handling

2.1 The product is delivered to site in rolls packed in a protective, branded bag sealed with an end label. Fitting instructions are placed in the bag.

2.2 The rolls should be stored in clean, dry conditions not exposed to sunlight. The product must be protected from being dropped or crushed by objects. Care must be exercised when storing large quantities on site. The product must

not be exposed to open flame or other ignition sources and must be stored away from flammable material such as paint and solvents.

2.3 On site, to ensure maximum performance of the product when installed, precautions must be taken to protect it from mud and dirt.

Assessment and Technical Investigations

The following is a summary of the assessment and technical investigations carried out on Rafterfit.

Design Considerations

3 Use

3.1 Rafterfit is a flexible insulation used in conjunction with other insulation materials to reduce the U value (thermal transmittance) in existing pitched roofs.

3.2 The product is for use in constructions where the ceiling follows the pitch of the roof and encloses a habitable space. The product can also be used in dwarf walls and dormer cheeks.

3.3 Care must be taken to ensure that the product is covered after installation, as it must not be exposed to rain, showers or wind-driven rain.

3.4 Care must be taken to ensure the product does not come into contact with heat sources greater than 80°C.

4 Thermal performance

4.1 Calculations of the thermal transmittance (U value) of specific roof constructions and dwarf walls/dormer cheeks incorporating Rafterfit 400 should be carried out in accordance with BS EN ISO 6946 : 1997 and BRE report (BR 443 : 2006), *Conventions for U-value calculations* using the following values:

- thermal resistance of insulation (thickness 30 mm) — 0.91 m²KW⁻¹
- emissivity of outer layers — 0.16

 4.2 The ultimate thermal performance of the product will depend on the construction of the roof on which it is installed and the combination of it with other insulation products is necessary to achieve the following design U values:

England and Wales and Northern Ireland

- 0.16 Wm²K⁻¹ required for 'notional' dwellings in SAP 2005
- 0.25 Wm²K⁻¹ limit average value specified in Approved Document L1A (Table 2) and Technical Booklet F1 (Table 2.2)
- 0.35 Wm²K⁻¹ limit for an individual element specified in Approved Document L1A (Table 2) and Technical Booklet F1 (Table 2.2).

Scotland

- 0.16 Wm²K⁻¹ for a 'notional' domestic roof required for all fuel packages in Mandatory Standard 6.1, clauses 6.1.6⁽¹⁾ and 6.1.2⁽¹⁾
- 0.20 Wm²K⁻¹ maximum average specified in Mandatory Standard 6.2, clause 6.2.1⁽¹⁾
- 0.35 Wm²K⁻¹ maximum value for an individual roof element specified in Mandatory Standard 6.2, clause 6.2.1⁽¹⁾
- 0.20 Wm²K⁻¹ for extensions as described in Mandatory Standard 6.2, clause 6.2.9⁽¹⁾.

(1) Technical Handbook (Domestic).

4.3 Where a proposed roof U value is higher than the relevant 'notional' value specified in section 4.2, additional energy saving measures will be required in the building envelope and/or services in order to achieve the required overall carbon dioxide emission rate reduction of about 20% in dwellings and 18% to 25% in Scotland.

4.4 Compliance with the guidance referred to in section 4.2 will allow the use of the default psi values from Table 3 of BRE Information Paper IP 1/06 *Assessing the effects of thermal bridging at junctions and around openings* and Table K1 of *The Government's Standard Assessment Procedure for Energy rating of Dwellings* (SAP 2005), in Target Emission Rate calculations to SAP 2005 use 'simplified approach' for Scotland).

4.5 The product can maintain or contribute to maintaining continuity of thermal insulation at junctions between the roof and other building elements, see also Figure 2. Guidance in this respect, and on limiting heat loss by air infiltration, can be found in:

England and Wales — *Limiting thermal bridging and air leakage: Robust construction details for dwellings and similar buildings* TSO 2002

Scotland — Accredited Construction Details (Scotland)

Northern Ireland — Accredited Construction Details (version 1.0).

Figure 2 Construction details

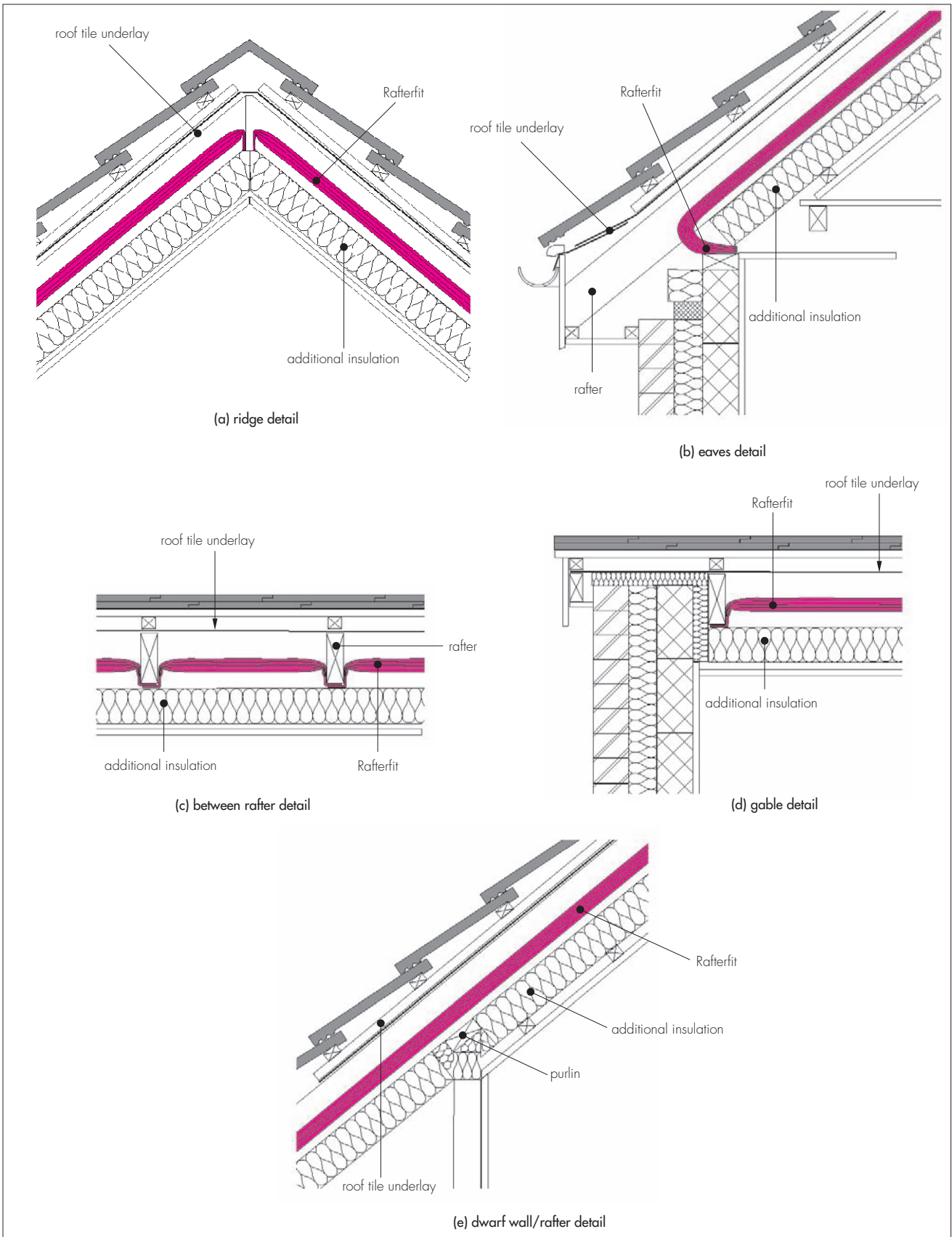

5 Condensation risk

Interstitial condensation



5.1 Roofs incorporating the product will adequately limit the risk of interstitial condensation when designed and constructed in accordance with BS 5250 : 2002, Section 8.4 and Appendix D.

5.2 The risk of interstitial condensation is greatest when the building is drying out after construction. Guidance on preventing condensation from this and other sources is given in BRE Digest 369 *Interstitial condensation and fabric degradation* and BRE report (BR 262 : 2002) *Thermal insulation : avoiding risks*.

5.3 The product has a high water vapour resistance in excess of 1200 MNsg^{-1} .

5.4 When installed in accordance with section 1.3 and in a continuous layer, the product will provide a convection-free envelope of high vapour resistance. Where the roof tile underlay is water vapour permeable, an unventilated layer should be left above Rafterfit 400. The use of a vapour control layer is also recommended when the insulation, used under rafters does not have a high vapour resistance.

5.5 In all cases, where high vapour resistance roof tile underlays are used, ventilation to the air space should be in accordance with the recommendations of BS 5250 : 2002 or relevant BBA Certificate for the roof tile underlay. When installed in conjunction with other insulation materials, the water vapour resistance and installation instructions of the additional insulation should be taken into consideration.

Surface condensation



5.6 Roofs will adequately limit the risk of surface condensation when the thermal transmittance (U value) does not exceed $0.35 \text{ Wm}^{-2}\text{K}^{-1}$ at any point and the junctions with walls are designed in accordance with the relevant requirements of *Limiting thermal bridging and air leakage : Robust construction details for dwellings and similar buildings*, TSO 2002 or BRE Information Paper IP 1/06.



5.7 Roofs will adequately limit the risk of surface condensation when the thermal transmittance (U value) does not exceed $1.2 \text{ Wm}^{-2}\text{K}^{-1}$ at any point. Guidance may be obtained from Section 8 of BS 5250 : 2002 and BRE Report (BR 262 : 2002).

6 Behaviour in relation to fire

6.1 When installed with an internal lining board, eg 12.5 mm thick plasterboard, the insulation will be contained between the roof and internal lining board, until one is destroyed. Therefore, the insulation will not contribute to the development stages of a fire or present a smoke or toxic hazard.



6.2 The insulation must not be carried over junctions between roofs and walls required to provide a minimum period of fire resistance. The continuity of fire resistance must be maintained, for example as described in:

England and Wales — Approved Document B, Volume 1, Sections 5.11 to 5.12

Scotland — Mandatory Standard 2.2, clause 2.2.10⁽¹⁾

(1) Technical Handbook (Domestic).

Northern Ireland — Technical Booklet E, paragraph 3.21.

6.3 The use of the product will not affect the fire rating obtained by tiled or slated roofs when evaluated by assessment or test to BS 476-3 : 2004.

6.4 When installed with other additional insulation materials, the fire properties of these materials must be taken into consideration.

7 Proximity of flues and appliances

When the product is installed in close proximity to certain flue pipes and/or heat-producing appliances, for buildings subject to national Building Regulations the relevant provisions and guidance given below should be met:

England and Wales — Approved Document J

Scotland — Mandatory Standard 3.19

Northern Ireland — Technical Booklet L.

8 Air leakage

8.1 When the product is used as an air barrier, the airtightness of the system is reliant on the careful sealing of the insulation and is dependent on maintaining the integrity of seal throughout. In addition to sealing at all joints, the insulation must be suitably sealed at the perimeter and all penetrations. Details of sealing at eaves, ridges, hips, valleys and penetrations must be in accordance with the Certificate holder's instructions.

8.2 The airtightness of the building will also be dependent on the performance of the other building elements. Provided these also incorporate appropriate design details and building techniques, air infiltration through the building fabric should be minimal and the building reasonably airtight.

9 De-rating of electrical cables

As with other insulation products, it may be necessary in some cases to de-rate electrical cables buried in insulation. In BS 7671 : 2001 it is suggested that where wiring is completely surrounded by insulation, it may need to be de-rated to as low as half its free air current carrying capacity. Guidance should be sought from a qualified electrician.

10 Maintenance and repair

Once installed, the product does not require any maintenance. Small holes, rips or punctures in the outer layers should be repaired with either Henkel 'Duck' brand duct tape (silver) or with an aluminium foil tape.

11 Durability



The product is rot-proof, does not tear easily and when installed as specified, will have a life equivalent to that of the roof structure in which it is incorporated.

Installation

12 General

12.1 Installation of Rafterfit and additional insulation products should be in accordance with the Certificate holder's instructions and current good building practice.

12.2 During construction, care must be taken to ensure the product is not damaged during installation. Should damage occur by tearing, the product should be repaired by covering the holes with tape (see also section 13.14) or replaced.

12.3 The product is attached to the rafters by using staples or nails of at least 14 mm length. Double-sided tape (as recommended by the manufacturer) can also be used.

12.4 The product can be cut easily by using a sharp knife with the product resting on a board, or with scissors. Where pieces of the product are to be joined, they should be taped on both sides on a flat surface before installation.

12.5 Any exposed cut edges of the product should be sealed with a suitable adhesive tape.

13 Procedure

13.1 The length of the sloping section of the roof from eaves to ridge is measured. The product is cut equal to the length of the sloping section of the roof plus 50 mm.

13.2 The product is positioned down two adjacent rafters with a 25 mm overlap at top and bottom. The edges of the wings are stapled along the bottom edge of each rafter. The central core of the product is pushed up into the rafter space and stapled to the inner face of the rafters on each side, ensuring that the central core runs straight across the rafter space, and that there is a 50 mm air space above and a 20 mm air space below the product.

13.3 At ridge detail, the final 20mm of the product is slit between the two welds, tucking the central core inside the rafter space and stapling it to the ridge beam, ensuring an airtight seal is made at both the sides and end of the rafter space.

13.4 At junction of roof and wall, the final 20 mm of the product is slit between the two welds, tucking the central core inside the rafter space and staple it to the top of the wall plate, ensuring an airtight seal is made at both the sides and end of the rafter space.

13.5 At purlins, the product should be taken up into the rafter space, behind the purlin. The ventilated air space above the product must not be obstructed.

13.6 At the junction of roof and dwarf wall, the product is run down the inside of the rafter space to the eaves, the wings are slit to go around the purlin. PUR board is then installed below the rafters above and below the purlin. The spaces are filled around the purlin with PUR board.

13.7 The product may also be fitted in vertical planes such as dwarf walls, dormer cheeks and gables provided timber studs or battens are spaced at approximately 400 mm centres.

Additional insulation

13.8 When used with other additional insulation materials, care should be taken to ensure that all gaps are maintained in accordance with the manufacturer's instructions for their products, and advice should be sought from the Certificate holder.

13.9 Rigid polyurethane (PUR) products can be placed between rafters. Suitable fixings such as wooden battens nailed to the sides of the rafters or clips should be used in accordance with the manufacturer's instructions.

Technical Investigations

14 Tests

Tests were carried out on Thinsulex Silver (see Product Sheet 1 of this Certificate) to determine the emissivity and durability of the outer foil and were used in the assessment of Rafterfit as the outer foil is the same.

15 Investigations

15.1 A re-examination was made of the data on which the first issue of Certificate No 06/4379 was based; the original conclusions remain valid.

15.2 An assessment of the risk of interstitial condensation in typical constructions was made.

Bibliography

- BS 476-3 : 2004 *Fire tests on building materials and structures — Classification and method of test for external fire exposure to roofs*
- BS 5250 : 2002 *Code of practice for control of condensation in buildings*
- BS 5534 : 2003 *Code of practice for slating and tiling (including shingles)*
- BS 7671 : 2001 *Requirements for electrical installations. IEE Wiring Regulations. Sixteenth Edition*
- BS EN ISO 6946 : 1997 *Building components and building elements — Thermal resistance and thermal transmittance — Calculation method*

Conditions of Certification

16 Conditions

16.1 This Certificate:

- relates only to the product/system that is named and described on the front page
- is granted only to the company, firm or person named on the front page — no other company, firm or person may hold or claim any entitlement to this Certificate
- is valid only within the UK
- has to be read, considered and used as a whole document — it may be misleading and will be incomplete to be selective
- is copyright of the BBA
- is subject to English law.

16.2 References in this Certificate to any Act of Parliament, Statutory Instrument, Directive or Regulation of the European Union, British, European or International Standard, Code of Practice, manufacturers' instructions or similar publication, are references to such publication in the form in which it was current at the date of this Certificate.

16.3 This Certificate will remain valid for an unlimited period provided that the product/system and the manufacture and/or fabrication including all related and relevant processes thereof:

- are maintained at or above the levels which have been assessed and found to be satisfactory by the BBA
- continue to be checked as and when deemed appropriate by the BBA under arrangements that it will determine
- are reviewed by the BBA as and when it considers appropriate.

16.4 In granting this Certificate, the BBA is not responsible for:

- the presence or absence of any patent, intellectual property or similar rights subsisting in the product/system or any other product/system
- the right of the Certificate holder to manufacture, supply, install, maintain or market the product/system
- individual installations of the product/system, including the nature, design, methods and workmanship of or related to the installation
- the actual works in which the product/system is installed, used and maintained, including the nature, design, methods and workmanship of such works.

16.5 Any information relating to the manufacture, supply, installation, use and maintenance of this product/system which is contained or referred to in this Certificate is the minimum required to be met when the product/system is manufactured, supplied, installed, used and maintained. It does not purport in any way to restate the requirements of the Health & Safety at Work etc Act 1974, or of any other statutory, common law or other duty which may exist at the date of this Certificate; nor is conformity with such information to be taken as satisfying the requirements of the 1974 Act or of any statutory, common law or other duty of care. In granting this Certificate, the BBA does not accept responsibility to any person or body for any loss or damage, including personal injury, arising as a direct or indirect result of the manufacture, supply, installation, use and maintenance of this product/system.

Web Dynamics Ltd

Moss Lane
Blackrod
Bolton
Lancashire BL6 5JB

Tel: 01204 695666 Fax: 01204 695333
e-mail: thinsulex@webdynamics.co.uk
website: www.webdynamics.co.uk



Agrément Certificate
No 06/4379

MULTIFOIL INSULATION**PRODUCT SHEET 2 — RAFTERFIT****PRODUCT SCOPE AND SUMMARY OF CERTIFICATE**

This Certificate relates to Rafterfit, a reflective insulation material for use in pitched roofs.

THIS CERTIFICATE INCLUDES:

- factors relating to compliance with UK Building Regulations where applicable
- factors relating to additional non-regulatory information where applicable
- independently verified technical specification
- assessment criteria and technical investigations
- design considerations
- installation guidance
- regular surveillance of production
- formal three-yearly review.

**KEY FACTORS ASSESSED**

Thermal performance — when combined with other types of insulation, the product can contribute in meeting the U value requirement for a roof (see section 4).

Condensation risk — the performance of the product with regard to interstitial and surface condensation has been considered (see section 5).

Behaviour in relation to fire — the roof system using this product can be designed to meet the UK requirements (see section 6).

Durability — the durability of the product is satisfactory and will have a life equivalent to that of the structure in which it is incorporated (see section 11).

The BBA has awarded this Agrément Certificate for Rafterfit to Web Dynamics Ltd as fit for its intended use provided it is installed, used and maintained as set out in this Agrément Certificate.

On behalf of the British Board of Agrément

Greg Cooper: Chief Executive

Date of First issue: 25 October 2007

The BBA is a UKAS accredited certification body — Number 113. The schedule of the current scope of accreditation for product certification is available in pdf format via the UKAS link on the BBA website at www.bbacerts.co.uk

Readers are advised to check the validity and latest issue number of this Agrément Certificate by either referring to the BBA website or contacting the BBA direct.

British Board of Agrément
Bucknalls Lane
Garston, Watford
Herts WD25 9BA

tel: 01923 665300
fax: 01923 665301
e-mail: mail@bba.star.co.uk
website: www.bbacerts.co.uk

©2007

Regulations

In the opinion of the BBA, Rafterfit, if used in accordance with the provisions of this Certificate, will meet or contribute to meeting the relevant requirements of the following Building Regulations:



The Building Regulations 2000 (as amended) (England and Wales)

Requirement:	B3(4)	Internal fire spread (structure)
Comment:		The product will not affect the external fire rating of a tiled or slated roof in which it is installed. See section 6.2 of this Certificate.
Requirement:	C2(c)	Resistance to moisture
Comment:		The product can contribute to a roof meeting this Requirement. See sections 5.1 and 5.6 of this Certificate.
Requirement:	L1(a)(i)	Conservation of fuel and power
Comment:		Roofs incorporating the product can contribute to a building meeting its Target Emission Rate. See sections 4.2 to 4.5 of this Certificate.
Requirement:	Regulation 7	Materials and workmanship
Comment:		The product is acceptable. See section 11 of this Certificate.



The Building (Scotland) Regulations 2004 (as amended)

Regulation:	8	Fitness and durability of materials and workmanship
Regulation:	8(1)	Fitness and durability of materials and workmanship
Comment:		The product can contribute to a construction satisfying this Regulation. See section 11 and the <i>Installation</i> part of this Certificate.
Regulation:	9	Building standards – construction
Standard:	2.2	Separation
Comment:		The product must not penetrate the separating wall junction with the roof to ensure that the fire-resistant integrity of the separating wall is maintained in accordance with clause 2.2.10 ⁽¹⁾ . See section 6.2 of this Certificate.
Standard:	3.15	Condensation
Comment:		The product can contribute to a roof satisfying the requirements of clauses 3.15.1 ⁽¹⁾ to 3.15.5 ⁽¹⁾ and 3.15.7 ⁽¹⁾ of this Standard. See sections 5.1 and 5.7 of this Certificate.
Standard:	6.1 (a)(b)	Carbon dioxide emissions
Standard:	6.2	Building insulation envelope
Comment:		The product can contribute to a roof satisfying the requirements of these Standards, with reference to clauses or parts of 6.1.2 ⁽¹⁾ , 6.1.6 ⁽¹⁾ , 6.2.1 ⁽¹⁾ , 6.2.3 ⁽¹⁾ , 6.2.4 ⁽¹⁾ and 6.2.5 ⁽¹⁾ . See sections 4.2 to 4.5 of this Certificate.
Regulation:	12	Building standards – conversions
Comment:		All comments given for this product under Regulation 9, also apply to this Regulation, with reference to clause 0.12.1 ⁽¹⁾ and Schedule 6 ⁽¹⁾ . (1) Technical Handbook (Domestic).



The Building Regulations (Northern Ireland) 2000 (as amended)

Regulation:	B2	Fitness of materials and workmanship
Comment:		The product is acceptable. See section 11 of this Certificate.
Regulation:	C5	Condensation
Comment:		The product can contribute to a roof satisfying the requirements of this Regulation. See section 5.1 of this Certificate.
Regulation:	E5(b)	External fire spread
Comment:		The product will not affect the external fire rating of a tiled or slated roof in which it is installed. See section 6.2 of this Certificate.
Regulation:	F2(a)(i)	Conservation measures
Regulation:	F3(2)	Target carbon dioxide Emissions Rate
Comment:		The product can contribute to a building satisfying its Target Emission Rate. See sections 4.2 to 4.5 of this Certificate.

Construction (Design and Management) Regulations 2007

Construction (Design and Management) Regulations (Northern Ireland) 2007

Information in this Certificate may assist the client, CDM co-ordinator, designer and contractors to address their obligations under these Regulations.

See section: 2 *Delivery and site handling* (2.2).

Non-regulatory Information

NHBC Standards 2007

NHBC accepts the use of Rafterfit, when installed and used in accordance with this Certificate, in relation to NHBC Standards, Chapter 7.2 *Pitched roofs*, Design Standard 7.2 – D10-D11 *Insulation and control of condensation*.

Zurich Building Guarantee Technical Manual 2007

In the opinion of the BBA, Rafterfit, when installed and used in accordance with this Certificate, satisfies the requirements of the *Zurich Building Guarantee Technical Manual*, Section 4 *Superstructure*, Sub-section *Pitched roofs*, pages 240 to 267.

General

This Certificate relates to Rafterfit and is for use as an insulation between rafters in tiled or slated pitched roofs designed and constructed in accordance with the relevant clauses of BS 5534 : 2003. The product can also be used in dormer cheeks and dwarf wall applications.

Technical Specification

1 Description

1.1 Rafterfit is an insulation material comprising outer layers of coated metallised film, laminated to a non-woven polypropylene fabric enclosing the core and welded along both long edges. The core of the product consists of five layers of polyester fibre wadding separated by four metallised film layers and it is secured together with two welds separated by 420 mm. The outer layers continue a further 56 mm beyond the weld on either side to form two wings. A further weld between the two outer layers is located at the edges (see Figure 1).

Figure 1 Rafterfit cross-section

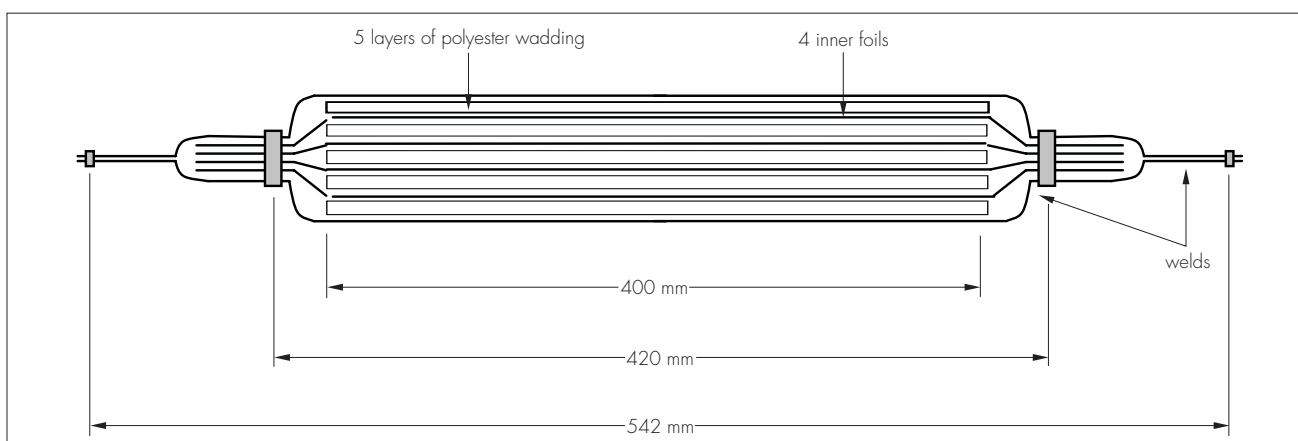

1.2 The product is available in roll form with a width of 550 mm, 10 m length and 30 mm thickness.

1.3 Ancillary items used with the product are:

- Henkel 'Duck' brand 50 mm duct tape (silver)
- Thinsulex tape, foil-backed tape with acrylic adhesive, width 50 mm, 75 mm or 100 mm⁽¹⁾
- 14 mm staples or nails⁽¹⁾
- vapour control layer⁽¹⁾
- roof tile underlay⁽¹⁾
- pre-treated counter battens, softwood battens and tiling laths⁽¹⁾
- roofing slates or tiles⁽¹⁾
- additional insulation where required⁽¹⁾

(1) Outside the scope of this Certificate.

2 Delivery and site handling

2.1 The product is delivered to site in rolls packed in a protective, branded bag sealed with an end label. Fitting instructions are placed in the bag.

2.2 The rolls should be stored in clean, dry conditions not exposed to sunlight. The product must be protected from being dropped or crushed by objects. Care must be exercised when storing large quantities on site. The product must

not be exposed to open flame or other ignition sources and must be stored away from flammable material such as paint and solvents.

2.3 On site, to ensure maximum performance of the product when installed, precautions must be taken to protect it from mud and dirt.

Assessment and Technical Investigations

The following is a summary of the assessment and technical investigations carried out on Rafterfit.

Design Considerations

3 Use

3.1 Rafterfit is a flexible insulation used in conjunction with other insulation materials to reduce the U value (thermal transmittance) in existing pitched roofs.

3.2 The product is for use in constructions where the ceiling follows the pitch of the roof and encloses a habitable space. The product can also be used in dwarf walls and dormer cheeks.

3.3 Care must be taken to ensure that the product is covered after installation, as it must not be exposed to rain, showers or wind-driven rain.

3.4 Care must be taken to ensure the product does not come into contact with heat sources greater than 80°C.

4 Thermal performance

4.1 Calculations of the thermal transmittance (U value) of specific roof constructions and dwarf walls/dormer cheeks incorporating Rafterfit 400 should be carried out in accordance with BS EN ISO 6946 : 1997 and BRE report (BR 443 : 2006), *Conventions for U-value calculations* using the following values:

- thermal resistance of insulation (thickness 30 mm) — 0.91 m²KW⁻¹
- emissivity of outer layers — 0.16

 4.2 The ultimate thermal performance of the product will depend on the construction of the roof on which it is installed and the combination of it with other insulation products is necessary to achieve the following design U values:

England and Wales and Northern Ireland

- 0.16 Wm⁻²K⁻¹ required for 'notional' dwellings in SAP 2005
- 0.25 Wm⁻²K⁻¹ limit average value specified in Approved Document L1A (Table 2) and Technical Booklet F1 (Table 2.2)
- 0.35 Wm⁻²K⁻¹ limit for an individual element specified in Approved Document L1A (Table 2) and Technical Booklet F1 (Table 2.2).

Scotland

- 0.16 Wm⁻²K⁻¹ for a 'notional' domestic roof required for all fuel packages in Mandatory Standard 6.1, clauses 6.1.6⁽¹⁾ and 6.1.2⁽¹⁾
- 0.20 Wm⁻²K⁻¹ maximum average specified in Mandatory Standard 6.2, clause 6.2.1⁽¹⁾
- 0.35 Wm⁻²K⁻¹ maximum value for an individual roof element specified in Mandatory Standard 6.2, clause 6.2.1⁽¹⁾
- 0.20 Wm⁻²K⁻¹ for extensions as described in Mandatory Standard 6.2, clause 6.2.9⁽¹⁾.

(1) Technical Handbook (Domestic).

4.3 Where a proposed roof U value is higher than the relevant 'notional' value specified in section 4.2, additional energy saving measures will be required in the building envelope and/or services in order to achieve the required overall carbon dioxide emission rate reduction of about 20% in dwellings and 18% to 25% in Scotland.

4.4 Compliance with the guidance referred to in section 4.2 will allow the use of the default psi values from Table 3 of BRE Information Paper IP 1/06 *Assessing the effects of thermal bridging at junctions and around openings* and Table K1 of *The Government's Standard Assessment Procedure for Energy rating of Dwellings* (SAP 2005), in Target Emission Rate calculations to SAP 2005 use 'simplified approach' for Scotland).

4.5 The product can maintain or contribute to maintaining continuity of thermal insulation at junctions between the roof and other building elements, see also Figure 2. Guidance in this respect, and on limiting heat loss by air infiltration, can be found in:

England and Wales — *Limiting thermal bridging and air leakage: Robust construction details for dwellings and similar buildings* TSO 2002

Scotland — Accredited Construction Details (Scotland)

Northern Ireland — Accredited Construction Details (version 1.0).

Figure 2 Construction details

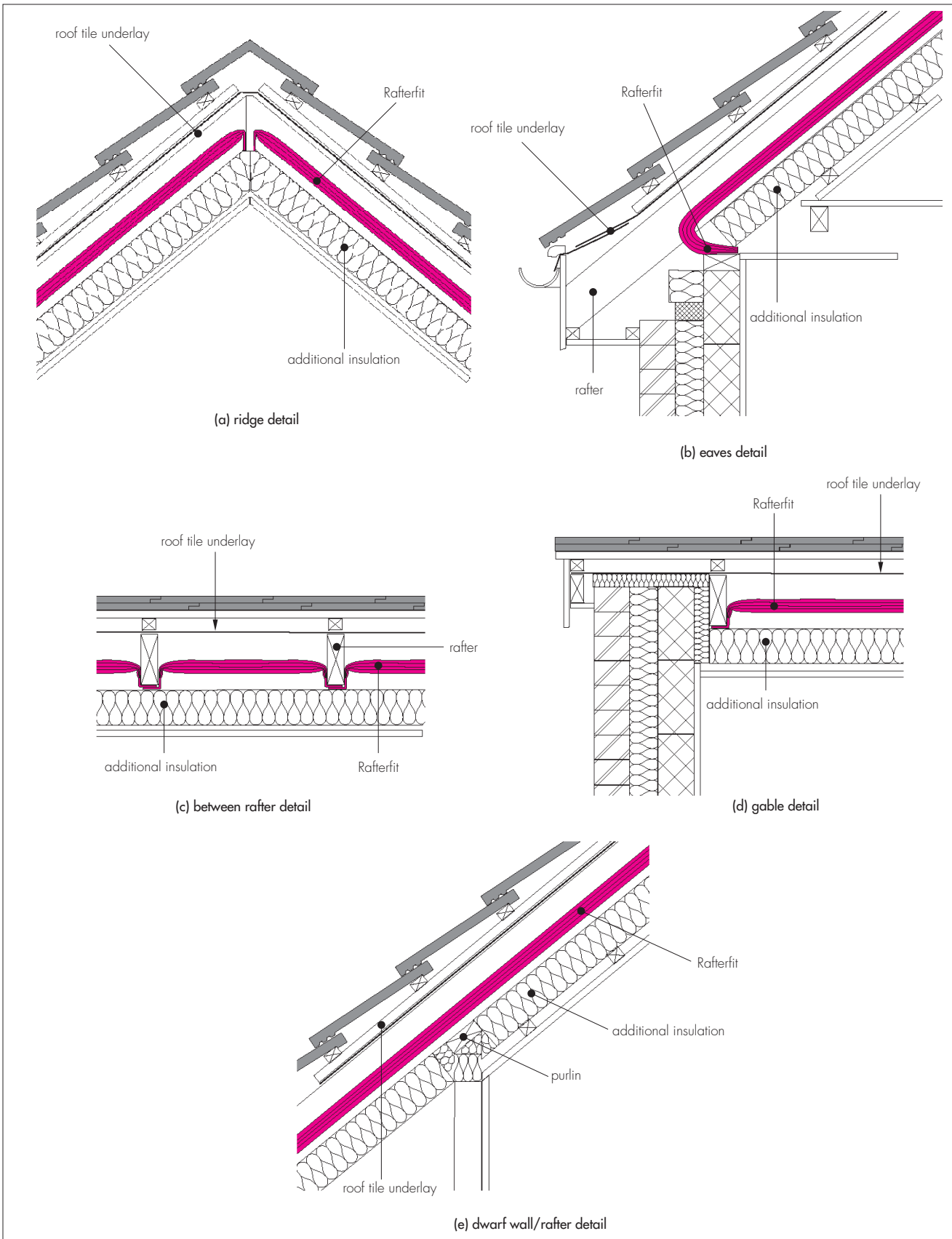

5 Condensation risk

Interstitial condensation



5.1 Roofs incorporating the product will adequately limit the risk of interstitial condensation when designed and constructed in accordance with BS 5250 : 2002, Section 8.4 and Appendix D.

5.2 The risk of interstitial condensation is greatest when the building is drying out after construction. Guidance on preventing condensation from this and other sources is given in BRE Digest 369 *Interstitial condensation and fabric degradation* and BRE report (BR 262 : 2002) *Thermal insulation : avoiding risks*.

5.3 The product has a high water vapour resistance in excess of 1200 MNsg^{-1} .

5.4 When installed in accordance with section 1.3 and in a continuous layer, the product will provide a convection-free envelope of high vapour resistance. Where the roof tile underlay is water vapour permeable, an unventilated layer should be left above Rafterfit 400. The use of a vapour control layer is also recommended when the insulation, used under rafters does not have a high vapour resistance.

5.5 In all cases, where high vapour resistance roof tile underlays are used, ventilation to the air space should be in accordance with the recommendations of BS 5250 : 2002 or relevant BBA Certificate for the roof tile underlay. When installed in conjunction with other insulation materials, the water vapour resistance and installation instructions of the additional insulation should be taken into consideration.

Surface condensation



5.6 Roofs will adequately limit the risk of surface condensation when the thermal transmittance (U value) does not exceed $0.35 \text{ Wm}^{-2}\text{K}^{-1}$ at any point and the junctions with walls are designed in accordance with the relevant requirements of *Limiting thermal bridging and air leakage : Robust construction details for dwellings and similar buildings*, TSO 2002 or BRE Information Paper IP 1/06.



5.7 Roofs will adequately limit the risk of surface condensation when the thermal transmittance (U value) does not exceed $1.2 \text{ Wm}^{-2}\text{K}^{-1}$ at any point. Guidance may be obtained from Section 8 of BS 5250 : 2002 and BRE Report (BR 262 : 2002).

6 Behaviour in relation to fire

6.1 When installed with an internal lining board, eg 12.5 mm thick plasterboard, the insulation will be contained between the roof and internal lining board, until one is destroyed. Therefore, the insulation will not contribute to the development stages of a fire or present a smoke or toxic hazard.



6.2 The insulation must not be carried over junctions between roofs and walls required to provide a minimum period of fire resistance. The continuity of fire resistance must be maintained, for example as described in:

England and Wales — Approved Document B, Volume 1, Sections 5.11 to 5.12

Scotland — Mandatory Standard 2.2, clause 2.2.10⁽¹⁾

(1) Technical Handbook (Domestic).

Northern Ireland — Technical Booklet E, paragraph 3.21.

6.3 The use of the product will not affect the fire rating obtained by tiled or slated roofs when evaluated by assessment or test to BS 476-3 : 2004.

6.4 When installed with other additional insulation materials, the fire properties of these materials must be taken into consideration.

7 Proximity of flues and appliances

When the product is installed in close proximity to certain flue pipes and/or heat-producing appliances, for buildings subject to national Building Regulations the relevant provisions and guidance given below should be met:

England and Wales — Approved Document J

Scotland — Mandatory Standard 3.19

Northern Ireland — Technical Booklet L.

8 Air leakage

8.1 When the product is used as an air barrier, the airtightness of the system is reliant on the careful sealing of the insulation and is dependent on maintaining the integrity of seal throughout. In addition to sealing at all joints, the insulation must be suitably sealed at the perimeter and all penetrations. Details of sealing at eaves, ridges, hips, valleys and penetrations must be in accordance with the Certificate holder's instructions.

8.2 The airtightness of the building will also be dependent on the performance of the other building elements. Provided these also incorporate appropriate design details and building techniques, air infiltration through the building fabric should be minimal and the building reasonably airtight.

9 De-rating of electrical cables

As with other insulation products, it may be necessary in some cases to de-rate electrical cables buried in insulation. In BS 7671 : 2001 it is suggested that where wiring is completely surrounded by insulation, it may need to be de-rated to as low as half its free air current carrying capacity. Guidance should be sought from a qualified electrician.

10 Maintenance and repair

Once installed, the product does not require any maintenance. Small holes, rips or punctures in the outer layers should be repaired with either Henkel 'Duck' brand duct tape (silver) or with an aluminium foil tape.

11 Durability



The product is rot-proof, does not tear easily and when installed as specified, will have a life equivalent to that of the roof structure in which it is incorporated.

Installation

12 General

12.1 Installation of Rafterfit and additional insulation products should be in accordance with the Certificate holder's instructions and current good building practice.

12.2 During construction, care must be taken to ensure the product is not damaged during installation. Should damage occur by tearing, the product should be repaired by covering the holes with tape (see also section 13.14) or replaced.

12.3 The product is attached to the rafters by using staples or nails of at least 14 mm length. Double-sided tape (as recommended by the manufacturer) can also be used.

12.4 The product can be cut easily by using a sharp knife with the product resting on a board, or with scissors. Where pieces of the product are to be joined, they should be taped on both sides on a flat surface before installation.

12.5 Any exposed cut edges of the product should be sealed with a suitable adhesive tape.

13 Procedure

13.1 The length of the sloping section of the roof from eaves to ridge is measured. The product is cut equal to the length of the sloping section of the roof plus 50 mm.

13.2 The product is positioned down two adjacent rafters with a 25 mm overlap at top and bottom. The edges of the wings are stapled along the bottom edge of each rafter. The central core of the product is pushed up into the rafter space and stapled to the inner face of the rafters on each side, ensuring that the central core runs straight across the rafter space, and that there is a 50 mm air space above and a 20 mm air space below the product.

13.3 At ridge detail, the final 20mm of the product is slit between the two welds, tucking the central core inside the rafter space and stapling it to the ridge beam, ensuring an airtight seal is made at both the sides and end of the rafter space.

13.4 At junction of roof and wall, the final 20 mm of the product is slit between the two welds, tucking the central core inside the rafter space and staple it to the top of the wall plate, ensuring an airtight seal is made at both the sides and end of the rafter space.

13.5 At purlins, the product should be taken up into the rafter space, behind the purlin. The ventilated air space above the product must not be obstructed.

13.6 At the junction of roof and dwarf wall, the product is run down the inside of the rafter space to the eaves, the wings are slit to go around the purlin. PUR board is then installed below the rafters above and below the purlin. The spaces are filled around the purlin with PUR board.

13.7 The product may also be fitted in vertical planes such as dwarf walls, dormer cheeks and gables provided timber studs or battens are spaced at approximately 400 mm centres.

Additional insulation

13.8 When used with other additional insulation materials, care should be taken to ensure that all gaps are maintained in accordance with the manufacturer's instructions for their products, and advice should be sought from the Certificate holder.

13.9 Rigid polyurethane (PUR) products can be placed between rafters. Suitable fixings such as wooden battens nailed to the sides of the rafters or clips should be used in accordance with the manufacturer's instructions.

Technical Investigations

14 Tests

Tests were carried out on Thinsulex Silver (see Product Sheet 1 of this Certificate) to determine the emissivity and durability of the outer foil and were used in the assessment of Rafterfit as the outer foil is the same.

15 Investigations

15.1 A re-examination was made of the data on which the first issue of Certificate No 06/4379 was based; the original conclusions remain valid.

15.2 An assessment of the risk of interstitial condensation in typical constructions was made.

Bibliography

BS 476-3 : 2004 *Fire tests on building materials and structures — Classification and method of test for external fire exposure to roofs*

BS 5250 : 2002 *Code of practice for control of condensation in buildings*

BS 5534 : 2003 *Code of practice for slating and tiling (including shingles)*

BS 7671 : 2001 *Requirements for electrical installations. IEE Wiring Regulations. Sixteenth Edition*

BS EN ISO 6946 : 1997 *Building components and building elements — Thermal resistance and thermal transmittance — Calculation method*

Conditions of Certification

16 Conditions

16.1 This Certificate:

- relates only to the product/system that is named and described on the front page
- is granted only to the company, firm or person named on the front page — no other company, firm or person may hold or claim any entitlement to this Certificate
- is valid only within the UK
- has to be read, considered and used as a whole document — it may be misleading and will be incomplete to be selective
- is copyright of the BBA
- is subject to English law.

16.2 References in this Certificate to any Act of Parliament, Statutory Instrument, Directive or Regulation of the European Union, British, European or International Standard, Code of Practice, manufacturers' instructions or similar publication, are references to such publication in the form in which it was current at the date of this Certificate.

16.3 This Certificate will remain valid for an unlimited period provided that the product/system and the manufacture and/or fabrication including all related and relevant processes thereof:

- are maintained at or above the levels which have been assessed and found to be satisfactory by the BBA
- continue to be checked as and when deemed appropriate by the BBA under arrangements that it will determine
- are reviewed by the BBA as and when it considers appropriate.

16.4 In granting this Certificate, the BBA is not responsible for:

- the presence or absence of any patent, intellectual property or similar rights subsisting in the product/system or any other product/system
- the right of the Certificate holder to manufacture, supply, install, maintain or market the product/system
- individual installations of the product/system, including the nature, design, methods and workmanship of or related to the installation
- the actual works in which the product/system is installed, used and maintained, including the nature, design, methods and workmanship of such works.

16.5 Any information relating to the manufacture, supply, installation, use and maintenance of this product/system which is contained or referred to in this Certificate is the minimum required to be met when the product/system is manufactured, supplied, installed, used and maintained. It does not purport in any way to restate the requirements of the Health & Safety at Work etc Act 1974, or of any other statutory, common law or other duty which may exist at the date of this Certificate; nor is conformity with such information to be taken as satisfying the requirements of the 1974 Act or of any statutory, common law or other duty of care. In granting this Certificate, the BBA does not accept responsibility to any person or body for any loss or damage, including personal injury, arising as a direct or indirect result of the manufacture, supply, installation, use and maintenance of this product/system.

Web Dynamics Ltd

Moss Lane
Blackrod
Bolton
Lancashire BL6 5JB
Tel: 01204 695666 Fax: 01204 695333
e-mail: tlx@webdynamics.co.uk
website: www.webdynamics.co.uk



Agrément Certificate
06/4379
Product Sheet 3

WEB DYNAMICS MULTIFOIL INSULATION

TLX SILVER FOR TIMBER FRAME AND MASONRY WALL APPLICATIONS

PRODUCT SCOPE AND SUMMARY OF CERTIFICATE

This Certificate relates to TLX Silver for Timber Frame and Masonry Wall Applications, a reflective insulation material, for use on the inside (warm side) of domestic and non-domestic walls.

AGRÉMENT CERTIFICATION INCLUDES:

- factors relating to compliance with Building Regulations where applicable
- factors relating to additional non-regulatory information where applicable
- independently verified technical specification
- assessment criteria and technical investigations
- design considerations
- installation guidance
- regular surveillance of production
- formal three-yearly review.



KEY FACTORS ASSESSED

Thermal performance — when combined with other types of insulation, the product can contribute to meeting the U value requirement for a wall (see section 5).

Condensation risk — the product will contribute to minimising the risk of interstitial and surface condensation. It has a water vapour resistance in excess of 1200 MNsg^{-1} and may be used as a vapour control layer (see section 6).

Behaviour in relation to fire — the product is classified as combustible but may be used in suitably designed walls (see section 8).

Air leakage — the product may be used as an air barrier (see section 9).

Durability — the durability of the product is satisfactory and will have a life equivalent to the structure in which it is incorporated (see section 13).

The BBA has awarded this Agrément Certificate to the company named above for the product described herein. This product has been assessed by the BBA as being fit for its intended use provided it is installed, used and maintained as set out in this Certificate.

On behalf of the British Board of Agrément

Date of First issue: 23 December 2008

Chris Hunt
Head of Approvals — Physics

Greg Cooper
Chief Executive

The BBA is a UKAS accredited certification body — Number 113. The schedule of the current scope of accreditation for product certification is available in pdf format via the UKAS link on the BBA website at www.bbacerts.co.uk

Readers are advised to check the validity and latest issue number of this Agrément Certificate by either referring to the BBA website or contacting the BBA direct.

British Board of Agrément
Bucknalls Lane
Garston, Watford
Herts WD25 9BA

©2008

tel: 01923 665300
fax: 01923 665301
e-mail: mail@bba.star.co.uk
website: www.bbacerts.co.uk

Regulations

In the opinion of the BBA, TLX Silver for Timber Frame and Masonry Wall Applications, if used in accordance with the provisions of this Certificate, will meet or contribute to meeting the relevant requirements of the following Building Regulations:



The Building Regulations 2000 (as amended) (England and Wales)

Requirement:	C2(c)	Resistance to moisture
Comment:		The product will contribute to minimising the risk of surface and interstitial condensation. See sections 6.1 and 6.3 of this Certificate.
Requirement:	L1(a)(i)	Conservation of fuel and power
Comment:		The product can contribute to meeting this requirement. See sections 5.2 to 5.5 of this Certificate.
Requirement:	Regulation 7	Materials and workmanship
Comment:		The product is an acceptable material. See section 13 and the <i>Installation</i> part of this Certificate.

In addition to the contribution which the product can make to meet the relevant Requirements, the following comments should be noted:

Requirement:	B3(4)	Internal fire spread (structure)
Comment:		Cavity barriers must be used to limit the extent of large cavities and to ensure integrity at junctions. See sections 8.1 and 8.2 of this Certificate.



The Building (Scotland) Regulations 2004 (as amended)

Regulation:	8(1)(2)	Fitness and durability of materials and workmanship
Comment:		The use of the product satisfies the requirements of this Regulation. See sections 12 and 13 and the <i>Installation</i> part of this Certificate.
Regulation:	9	Building standards – construction
Standard:	2.6	Spread to neighbouring buildings
Comment:		The product is combustible but may be used in walls of buildings in accordance with the exceptions permitted in this Standard, with reference to clause 2.6.5 ⁽¹⁾⁽²⁾ . See section 8.1 of this Certificate.
Standard:	3.15	Condensation
Comment:		The product can contribute to satisfying this Standard, with reference to clauses 3.15.1 ⁽¹⁾ , 3.15.4 ⁽¹⁾ and 3.15.5 ⁽¹⁾ . See sections 6.2 and 6.3 of this Certificate.
Standard:	6.1(b)	Carbon dioxide emissions
Standard:	6.2	Building insulation envelope
Comment:		The product can contribute to satisfying clauses, or parts of 6.1.0 ⁽¹⁾⁽²⁾ to 6.1.5 ⁽¹⁾⁽²⁾ , 6.1.6 ⁽¹⁾ and 6.1.7 ⁽¹⁾ 6.2.0 ⁽¹⁾⁽²⁾ to 6.2.12 ⁽¹⁾⁽²⁾ of these Standards. See sections 5.2 to 5.5 of this Certificate. (1) Technical Handbook (Domestic). (2) Technical Handbook (Non-Domestic).

In addition to the contribution which the product can make to meet the relevant Standards, the following comments should be noted:

Standard:	2.4	Cavities
Comment:		Wall cavities incorporating the product must comply with this Standard, with reference to clauses 2.2.4 ⁽²⁾ , 2.2.7 ⁽¹⁾ , 2.4.1 ⁽¹⁾⁽²⁾ , 2.4.2 ⁽¹⁾⁽²⁾ , 2.4.7 ⁽¹⁾ and 2.4.9 ⁽²⁾ . See sections 8.1 and 8.2 of this Certificate.



The Building Regulations (Northern Ireland) 2000 (as amended)

Regulation:	B2	Fitness of materials and workmanship
Comment:		The product is acceptable. See section 13 and the <i>Installation</i> part of this Certificate.
Regulation:	B3(2)	Suitability of certain materials
Comment:		The product is an acceptable material. See section 12 of this Certificate.
Regulation:	C5	Condensation
Comment:		The product will contribute to minimising the risk of interstitial condensation. See section 6.3 of this Certificate.
Regulation:	F2(a)(i)	Conservation measures
Regulation:	F3(2)	Target carbon dioxide Emissions Rate
Comment:		The product can contribute to satisfying these Regulations. See sections 5.2 to 5.5 of this Certificate.

In addition to the contribution which the product can make to meet the relevant Regulations, the following comments should be noted:

Regulation:	E4	Internal fire spread – Structure
Comment:		Cavity barriers must be used to limit the extent of large cavities and to ensure integrity at junctions. See sections 8.1 and 8.2 of this Certificate.

Construction (Design and Management) Regulations 2007

Construction (Design and Management) Regulations (Northern Ireland) 2007

In the opinion of the BBA, there is no information in this Certificate which relates to the obligations of the client, CDM co-ordinator, designer and contractors under these Regulations.

Non-regulatory Information

NHBC Standards 2008

NHBC accepts the use of TLX Silver for Timber Frame and Masonry Wall Applications, when installed and used in accordance with this Certificate, in relation to *NHBC Standards*, Chapter 6.1 *External walls and masonry walls* and Chapter 6.2 *External timber framed walls*.

Zurich Building Guarantee Technical Manual 2007

In the opinion of the BBA, TLX Silver for Timber Frame and Masonry Wall Applications, when installed and used in accordance with this Certificate, satisfies the requirements of the *Zurich Building Guarantee Technical Manual*, Section 4 *Superstructure*, Sub-sections *External walls – masonry*, *External walls – thermal insulation* and *External walls – timber frame*.

General

This Certificate relates to TLX Silver for Timber Frame and Masonry Wall Applications and is for use as an insulation to reduce the thermal transmittance of timber frame walls and masonry walls. The product is for use on the inner side (warm side) of the timber frame or masonry substrate and held in place by timber battens creating an airspace between the product and internal lining.

Technical Specification

1 Description

1.1 TLX Silver for Timber Frame and Masonry Wall Applications is an insulation material comprising outer layers of coated metallised film, laminated to a non-woven polypropylene fabric enclosing the core and welded along both long edges. The core of the product consists of five layers of polyester fibre wadding, separated by four metallised film layers.

1.2 The product is supplied in rolls of 10 m length, 1.2 m wide and 30 mm thick.

1.3 Ancillary components (not covered by this Certificate) include:

- Henkel 'Duck' brand 50 mm adhesive tape
- TLX tape, foil backed tape with acrylic adhesive, 50 mm, 75 mm or 100 mm
- timber battens
- plasterboard to BS EN 520 : 2004
- screws
- nails or staples.
- additional insulation where required.

2 Delivery and site handling

2.1 The product is delivered to site in rolls packed in a protective, branded bag, sealed with a label.

2.2 The product should be stored in clean, dry conditions not exposed to sunlight. The product must be protected from being dropped or crushed by objects. Care must be exercised when storing large quantities on site. The product must not be exposed to open flame or other ignition sources and must be stored away from flammable material such as paint and solvents.

2.3 To ensure maximum performance of the product when installed, precautions must be taken on site to protect it from mud and dirt.

Assessment and Technical Investigations

The following is a summary of the assessment and technical investigations carried out on TLX Silver for Timber Frame and Masonry Wall Applications.

Design Considerations

3 General

3.1 TLX Silver for Timber Frame and Masonry Wall Applications will improve the thermal insulation of dwellings and buildings of similar occupancy, type and condition.

3.2 The wall or sub-frame should be structurally sound and should have been designed and constructed in accordance with the following standards :

- timber — BS 5268-2 : 2002, BS 5268-5 : 1989, BS 5589 : 1989 and BS EN 351-1 : 1996.
- masonry — BS 5628-1 : 2005, BS 5628-3 : 2005, BS 8110-1 : 1997, BS 8110-2 : 1985, BS EN 1996-2 : 2006.

3.3 The installation requires careful detailing around doors and windows to achieve a satisfactory surface for finishing. In addition, every attempt should be made to minimise the risk of thermal bridging at reveals and where heavy separating walls are attached to the external wall. In new work, the construction must be designed to accommodate the thickness of the dry lining, particularly at reveals, heads, sills and in relation to ceiling height.

3.4 Services can be incorporated behind the dry lining, making chasing of the wall unnecessary. Where possible, penetration of the product by services should be kept to a minimum to limit possible penetration by water vapour.

3.5 Installation of plasterboard must be in accordance with the relevant sections of BS 8212 : 1995.

4 Practicability of installation

The product can be readily installed by operatives experienced with this type of product.

5 Thermal performance

5.1 Calculations of thermal transmittance (U value) should be carried out in accordance with BS EN ISO 6946 : 2007, BRE report *Conventions for U-value calculations* (BR 443 : 2006) and:

- 0.92 m²KW⁻¹ products core thermal resistance (with no air space either side)
- 0.16 products external surface emissivity
- 0.487 m²KW⁻¹ resistance of an unventilated air cavity (min 15 mm) adjacent to the product.



5.2 The product can achieve or contribute to achieving the following design U values, when used with additional insulation:

England and Wales and Northern Ireland

- 0.35 Wm⁻²K⁻¹ required for 'notional' dwellings in SAP 2005 and buildings other than dwellings in SBEM (see also section 5.5)
- 0.35 Wm⁻²K⁻¹ limit average specified in Approved Documents L1A (Table 2) and L2A (Table 4), and Technical Booklets F1 (Table 2.2) and F2 (Table 2.4) (see also section 5.5)
- 0.70 Wm⁻²K⁻¹ limit for an individual element specified in Approved Documents L1A (Table 2) and L2A (Table 4), Technical Booklets F1 (Table 2.2) and F2 (Table 2.4).

Scotland

- 0.20 Wm⁻²K⁻¹ required for the 'simplified approach — solid fuel package 6' 'notional' dwelling in Mandatory Standard 6.1, clause 6.1.6⁽¹⁾
- 0.25 Wm⁻²K⁻¹ required for 'notional' dwellings in SAP 2005 (for Scotland) and the 'simplified approach — packages 1 to 5' in Mandatory Standard 6.1, clause 6.1.6⁽¹⁾
- 0.30 Wm⁻²K⁻¹ limit average specified in Mandatory Standard 6.2, clause 6.2.1⁽¹⁾⁽²⁾
- 0.70 Wm⁻²K⁻¹ limit for an individual element specified in Mandatory Standard 6.2, clause 6.2.1⁽¹⁾⁽²⁾.

(1) Technical Handbook (Domestic).

(2) Technical Handbook (Non-Domestic).

5.3 Where a proposed wall U value is not better than (or is greater than in Scotland) the relevant 'notional' value specified in section 5.4, additional energy saving measures will be required in the building envelope and/or services to achieve the required overall carbon dioxide emission rate reduction of about 20% in dwellings (18% to 25% in Scotland) and 23% to 28% in buildings other than dwellings.

5.4 The product can maintain or contribute to maintaining continuity of thermal insulation at junctions between the external wall and the other building elements. Guidance in this respect, and on limiting heat loss by air infiltration, can be found in:

England and Wales — *Limiting thermal bridging and air leakage : Robust construction details for dwellings and similar buildings* TSO 2002 or Accredited Construction Details (version 1.0).

Scotland — Accredited Construction Details (Scotland).

Northern Ireland — Accredited Construction Details (version 1.0).

5.5 Compliance with the guidance referred to in section 5.4 will allow the use of the default psi values from Table 3 of BRE Information Paper 1/06 *Assessing the effects of thermal bridging at junctions and around openings* and Table K1 of *The Government's Standard Assessment Procedure for Energy Rating of Dwellings* (SAP 2005), in Target Emission Rate calculations to SAP 2005 or the Simplified Building Energy Model (SBEM).

6 Condensation risk

Surface condensation



6.1 Walls will limit the risk of surface condensation adequately when the thermal transmittance (U value) does not exceed $0.7 \text{ Wm}^{-2}\text{K}^{-1}$ at any point, and the junctions with other elements are designed in accordance with the relevant requirements of *Limiting thermal bridging and air leakage : Robust construction details for dwellings and similar buildings* TSO 2002 or BRE Information Paper IP 1/06 .



6.2 Walls and ceilings will adequately limit the risk of surface condensation when the thermal transmittance (U value) does not exceed $1.2 \text{ Wm}^{-2}\text{K}^{-1}$ at any point. Guidance may be obtained from Section 8 of the BS 5250 : 2002 and BRE report (BR 262 : 2002) *Thermal insulation : avoiding risks*.

Interstitial condensation



6.3 Walls incorporating the product will adequately limit the risk on interstitial condensation when they are designed and constructed in accordance with BS 5250 : 2002 (Section 8 and Annex D).

6.4 The product has a high water vapour resistance in excess of 1200 MNsg^{-1} and will, therefore, provide significant resistance to the passage of water vapour and would be considered a vapour control layer as defined in BS 5250 : 2002 provided all laps and joints are sealed.

6.5 The use of the product does not preclude the normal precautions against formation of condensation, especially in rooms expected to have high humidity.

6.6 When using this type of product, due consideration must be taken of the overall installation to minimise perforations by services, eg light switches and power outlets and the joints at ceiling and skirting level must be well sealed.

6.7 As with any other insulation applied to the inside of a wall, there may be risk of thermal bridging from the floor or ceiling, particularly in concrete slab construction. It has been demonstrated that the use of coving at the wall ceiling point will significantly reduce the problem.

7 Infestation

The use of the product does not in itself promote infestation. The creation of voids may provide habitation for insects or rodents in areas already infested. Care should be taken to ensure that, wherever possible, all voids are sealed as any infestation may be difficult to eradicate. There is no food value in the materials used.

8 Behaviour in relation to fire



8.1 The Certificate holder has declared that the product, when tested for reaction to fire to BS EN ISO 11925-2 : 2002, achieved a Class E rating in accordance with BS EN 13501-1 : 2007.

8.2 When installed with an internal lining board, eg 12.5 mm thick plasterboard, the insulation will be contained between the wall and internal lining board, until one is destroyed. Therefore, the insulation will not contribute to the development stages of a fire.

8.3 When installed with other additional insulation materials, the fire properties of these materials must be taken into consideration.

9 Air leakage

9.1 The insulation was tested to BS EN 12114 : 2000 with positive pressure of 50 Pa, the product achieved a leakage rate of $0.19 \text{ m}^3\text{hr}^{-1}\text{m}^{-2}$.

9.2 When the product is used as a vapour control layer and an air barrier, its effectiveness is reliant on the careful sealing of the laps, joints, perimeters and penetrations, in accordance with the Certificate holder's instructions.

9.3 The airtightness of the building will also be dependent on the performance of the other building elements.

10 Derating of electrical cables

As with other insulation products, it may be necessary in some cases to de-rate electrical cables buried in insulation. BS 7671 : 2008 suggests that where wiring is completely surrounded by insulation, it may need to be de-rated to as low as half its free air current carrying capacity. Guidance should be sought from a qualified electrician.

11 Proximity of flues and appliances

When installing the product in close proximity to certain flue pipes and/or heat-producing appliances, the following provisions to the national Building Regulations are acceptable:

England and Wales — Approved Document J

Scotland — Mandatory Standard 3.19, clause 3.19.1⁽¹⁾⁽²⁾

(1) Technical Handbook (Domestic).

(2) Technical Handbook (Non-Domestic).

Northern Ireland — Technical Booklet L.

12 Maintenance



As the product is confined behind the wall lining and it has suitable durability (see section 13), maintenance is not required.

13 Durability



The product will have a life equivalent to that of the wall structure in which they are incorporated.

Installation

14 General

14.1 Installation of TLX Silver for Timber Frame and Masonry Wall Applications and additional insulation products should be in accordance with the Certificate holder's instructions and current good building practice.

14.2 Care must be taken to ensure the product is not damaged during installation. Should damage occur by tearing, the product should be repaired by covering the holes with tape. The product is attached to wall studs using staples or nails of at least 14 mm length. The product must have overlap joints of at least 50 mm and be taped along the entire length of the joint with TLX tape or Henkel silver Duck tape.

14.3 When the product is cut to fit around openings, care should be taken to minimise gaps. The product can be cut easily using sharp scissors or a knife. Any exposed cut edges of the product should be sealed with a suitable adhesive tape.

15 Procedure

Timber frame wall

15.1 Installation may be either vertical or horizontal runs. If horizontal, installation should start at the floor and go up to the ceiling.

15.2 The product is unrolled across the inside of the timber studs and fixed using staples or nails of at least 14 mm length.

15.3 The next layer must overlap the first layer by at least 50 mm and be taped along the entire length of the joint with TLX tape or Henkel silver Duck tape. If securely taped, the product can also function as a vapour control layer and air barrier.

15.4 The product should be permanently fixed in place using wooden battens of size at least 32 mm by 25 mm, parallel or perpendicular to the wall studs held in place with nails.

15.5 When the top layer has been battened, any excess material may be removed by running a sharp knife along the edge of the batten.

15.6 Plasterboard is fixed to the battens in the conventional manner.

Solid masonry wall

15.7 Timber battens at least 32mm deep by 25 mm wide are screwed to the wall at no greater than 600 mm vertical centres, at wall perimeters and horizontally as required.

15.8 The product is installed as for timber frame walls with plasterboard battens coinciding with the existing battens.

Additional insulation

15.9 When used with additional insulation, care should be taken that all air gaps are maintained in accordance with their products and advice should be sought from the Certificate holder. Mineral wool can be placed inside the cavity formed when the product is installed across studs. Rigid insulation products can be placed inside the cavity. Suitable fixings such as wooden battens nailed to the sides of the studs can be used to generate an air layer between the rigid insulation and the other components of the wall.

Technical Investigations

16 Tests

Tests were carried out on TLX Silver for Timber Frame and Masonry Wall Applications to determine the emissivity and durability of the outer foil and the core thermal resistance.

Bibliography

- BS 5250 : 2002 *Code of practice for control of condensation in buildings*
- BS 5268-2 : 2002 *Structural use of timber — Code of practice for permissible stress design, materials and workmanship*
- BS 5268-5 : 1989 *Structural use of timber — Code of practice for the preservative treatment of structural timber*
- BS 5589 : 1989 *Code of practice for preservation of timber*
- BS 5628-1 : 2005 *Code of practice for the use of masonry — Structural use of unreinforced masonry*
- BS 5628-3 : 2005 *Code of practice for the use of masonry — Materials and components, design and workmanship*
- BS 7671 : 2008 *Requirements for electrical installations. IEE Wiring Regulations. Seventeenth Edition*
- BS 8110-1 : 1997 *Structural use of concrete — Code of practice for design and construction*
- BS 8110-2 : 1985 *Structural use of concrete — Code of practice for special circumstances*
- BS 8212 : 1995 *Code of practice for dry lining and partitioning using gypsum plasterboard*
- BS EN 351-1 : 1996 *Durability of wood and wood-based products — Preservative-treated solid wood — Classification of preservative penetration and retention*
- BS EN 520 : 2004 *Gypsum plasterboards — Definitions, requirements and test methods*
- BS EN 1996-2 : 2006 *Eurocode 6 — Design of masonry structures— Design considerations, selection of materials and execution of masonry*
- BS EN 12114 : 2000 *Thermal performance of buildings — Air permeability of building components and building elements — Laboratory test method*
- BS EN 13501-1 : 2007 *Fire classification of construction products and building elements. Classification using test data from reaction to fire tests*
- BS EN ISO 6946 : 2007 *Building components and building elements — Thermal resistance and thermal transmittance — Calculation method*
- BS EN ISO 11925-2 : 2002 *Reaction to fire tests — Ignitability of building products subjected to direct impingement of flame — Single-flame source test*

17 Conditions

17.1 This Certificate:

- relates only to the product/system that is named and described on the front page
- is granted only to the company, firm or person named on the front page — no other company, firm or person may hold or claim any entitlement to this Certificate
- is valid only within the UK
- has to be read, considered and used as a whole document — it may be misleading and will be incomplete to be selective
- is copyright of the BBA
- is subject to English law.

17.2 References in this Certificate to any Act of Parliament, Statutory Instrument, Directive or Regulation of the European Union, British, European or International Standard, Code of Practice, manufacturers' instructions or similar publication, are references to such publication in the form in which it was current at the date of this Certificate.

17.3 This Certificate will remain valid for an unlimited period provided that the product/system and the manufacture and/or fabrication including all related and relevant processes thereof:

- are maintained at or above the levels which have been assessed and found to be satisfactory by the BBA
- continue to be checked as and when deemed appropriate by the BBA under arrangements that it will determine
- are reviewed by the BBA as and when it considers appropriate.

17.4 In granting this Certificate, the BBA is not responsible for:

- the presence or absence of any patent, intellectual property or similar rights subsisting in the product/system or any other product/system
- the right of the Certificate holder to manufacture, supply, install, maintain or market the product/system
- individual installations of the product/system, including the nature, design, methods and workmanship of or related to the installation
- the actual works in which the product/system is installed, used and maintained, including the nature, design, methods and workmanship of such works.

17.5 Any information relating to the manufacture, supply, installation, use and maintenance of this product/system which is contained or referred to in this Certificate is the minimum required to be met when the product/system is manufactured, supplied, installed, used and maintained. It does not purport in any way to restate the requirements of the Health & Safety at Work etc Act 1974, or of any other statutory, common law or other duty which may exist at the date of this Certificate; nor is conformity with such information to be taken as satisfying the requirements of the 1974 Act or of any statutory, common law or other duty of care. In granting this Certificate, the BBA does not accept responsibility to any person or body for any loss or damage, including personal injury, arising as a direct or indirect result of the manufacture, supply, installation, use and maintenance of this product/system.