



## Wavin Plastics Ltd

Parsonage Way  
 Chippenham  
 Wiltshire SN15 5PN  
 Tel: 01249 766600 Fax: 01249 443286  
 e-mail: info@wavin.co.uk  
 website: www.wavin.co.uk

(52)	In6
------	-----

**Agrément  
 Certificate  
 No 02/3940**  
*Second issue\**

Designated by Government  
 to issue  
 European Technical  
 Approvals

## WAVIN TWIN WALL DRAINAGE SYSTEM

Systèmes de canalisations d'évacuation  
 Abflußleitungen

# Product



- THIS CERTIFICATE RELATES TO THE WAVIN TWIN WALL DRAINAGE SYSTEM, COMPRISING TWIN WALL PIPE AND COUPLINGS.
  - This Certificate covers the use of the pipe for surface water only.
- These Front Sheets must be read in conjunction with the accompanying Detail Sheets which provide information to specific systems.

## Regulations — Detail Sheet 1

<b>1 The Building Regulations 2000 (as amended) (England and Wales)</b>	
	The Secretary of State has agreed with the British Board of Agrément the requirements of the Building Regulations to which surface water pipe can contribute in achieving compliance. In the opinion of the BBA, the Wavin Twin Wall Drainage System, if used in accordance with the provisions of this Certificate, will meet or contribute to meeting the relevant requirements.
Requirement: H3(3)	Rainwater drainage
Comment:	The system will convey the flow of rainwater and minimise the risk of blockages or leakage. See the <i>Flow characteristics</i> section of the relevant accompanying Detail Sheet.
Requirement: Regulation 7	Materials and workmanship
Comment:	The system is acceptable. See the <i>Durability</i> section of the relevant accompanying Detail Sheet.

# Electronic Copy

## 2 The Building Standards (Scotland) Regulations 1990 (as amended)



In the opinion of the BBA, the Wavin Twin Wall Drainage System, if used in accordance with the provisions of this Certificate, will satisfy or contribute to satisfying the various Regulations and related Technical Standards as listed below.

Regulation:	10	Fitness of materials and workmanship
Standard:	B2.1	Selection and use of materials, fittings, and components, and workmanship
Comment:		The system complies with this Standard. See the <i>Installation</i> part of the accompanying Detail Sheets.
Standard:	B2.2	Selection and use of materials, fittings, and components, and workmanship
Comment:		The system is acceptable. See the <i>Durability</i> section of the relevant accompanying Detail Sheet.
Regulation:	24	Drainage and sanitary facilities
Standard:	M2.1	Drainage system
Comment:		The system will meet the relevant requirements of this Standard. See the <i>Flow characteristics</i> section of the relevant accompanying Detail Sheet.

## 3 The Building Regulations (Northern Ireland) 2000



In the opinion of the BBA, the Wavin Twin Wall Drainage System, if used in accordance with the provisions of this Certificate, will satisfy or contribute to satisfying the various Building Regulations as listed below.

Regulation:	B2	Fitness of materials and workmanship
Comment:		The system is acceptable. See the <i>Durability</i> section of the relevant accompanying Detail Sheet.
Regulation:	N5	Rainwater drainage
Comment:		The system will meet the relevant requirements of this Regulation. See the <i>Flow characteristics</i> section of the relevant accompanying Detail Sheet.

## 4 Construction (Design and Management) Regulations 1994 (as amended) Construction (Design and Management) Regulations (Northern Ireland) 1995 (as amended)

Information in this Certificate may assist the client, planning supervisor, designer and contractors to address their obligations under these Regulations.

See sections: 1 *Description* (1.3), 2 *Delivery and site handling* (2.1), 3 *General* and 12 *General* of the *Installation* part of the relevant accompanying Detail Sheet.

## Conditions of Certification

### 5 Conditions

5.1 This Certificate:

- (a) relates only to the product that is named, described, installed, used and maintained as set out in this Certificate;
- (b) is granted only to the company, firm or person identified on the front cover — no other company, firm or person may hold or claim any entitlement to this Certificate;
- (c) is valid only within the UK;
- (d) has to be read, considered and used as a whole document — it may be misleading and will be incomplete to be selective;
- (e) is copyright of the BBA;
- (f) is subject to English law.

5.2 References in this Certificate to any Act of Parliament, Regulation made thereunder, Directive or Regulation of the European Union, Statutory Instrument, Code of Practice, British Standard, manufacturers' instructions or similar publication, are references to such publication in the form in which it was current at the date of this Certificate.

5.3 This Certificate will remain valid for an unlimited period provided that the product and the manufacture and/or fabrication including all related and relevant processes thereof:

- (a) are maintained at or above the levels which have been assessed and found to be satisfactory by the BBA;

(b) continue to be checked as and when deemed appropriate by the BBA under arrangements that it will determine; and

(c) are reviewed by the BBA as and when it considers appropriate.

5.4 In granting this Certificate, the BBA is not responsible for:

- (a) the presence or absence of any patent, intellectual property or similar rights subsisting in the product or any other product;
- (b) the right of the Certificate holder to market, supply, install or maintain the product; and
- (c) the actual works in which the product is installed, used and maintained, including the nature, design, methods and workmanship of such works.

5.5 Any recommendations relating to the use or installation of this product which are contained or referred to in this Certificate are the minimum standards required to be met when the product is used. They do not purport in any way to restate the requirements of the Health & Safety at Work etc Act 1974, or of any other statutory, common law or other duty which may exist at the date of this Certificate or in the future; nor is conformity with such recommendations to be taken as satisfying the requirements of the 1974 Act or of any present or future statutory, common law or other duty of care. In granting this Certificate, the BBA does not accept responsibility to any person or body for any loss or damage, including personal injury, arising as a direct or indirect result of the installation and use of this product.



In the opinion of the British Board of Agrément, the Wavin Twin Wall Drainage System is fit for its intended use provided it is installed, used and maintained as set out in this Certificate. Certificate No 02/3940 is accordingly awarded to Wavin Plastics Ltd.

On behalf of the British Board of Agrément

Date of Second issue: 23rd February 2005

Chief Executive

*\*Original Front Sheets issued on 10th July 2002. This amended version includes new Conditions of Certification.*

# Electronic Copy

---

**British Board of Agrément**

P O Box No 195, Bucknalls Lane  
Garston, Watford, Herts WD25 9BA  
Fax: 01923 665301

©2005

e-mail: [mail@bba.star.co.uk](mailto:mail@bba.star.co.uk)  
website: [www.bbacerts.co.uk](http://www.bbacerts.co.uk)



For technical or additional information,  
contact the Certificate holder (see  
front page).  
For information about the Agrément  
Certificate, including validity and  
scope, tel: Hotline 01923 665400,  
or check the BBA website.



**WAVIN TWIN WALL, HIGH DENSITY, POLYETHYLENE FILTER AND CARRIER PIPES (WITH INTERNAL PIPE DIAMETERS OF 150 mm, 225 mm AND 300 mm), RING SEALS AND COUPLINGS**

## Product

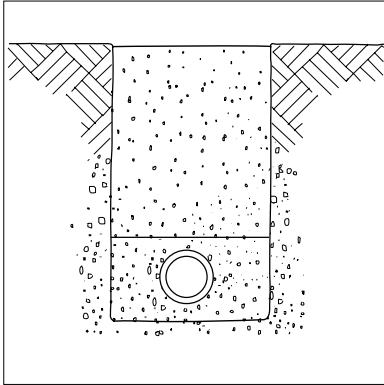

• THIS DETAIL SHEET RELATES TO WAVIN TWIN WALL, HIGH DENSITY, POLYETHYLENE FILTER AND CARRIER PIPES (WITH INTERNAL PIPE DIAMETERS OF 150 mm, 225 mm AND 300 mm), RING SEALS AND COUPLINGS.

• The pipes, ring seals and couplings are for use in highway drainage for the collection and disposal of surface and sub-surface water.

This Detail Sheet must be read in conjunction with the Front Sheets, which give the product's position regarding the Building Regulations and the Conditions of Certification.

## Technical Specification

### 1 Description

1.1 Wavin Twin Wall filter and carrier (slotted and unslotted) pipes are manufactured in black polyethylene by a twin extrusion process. Two high-density polyethylene pipes are extruded simultaneously, one inside the other, and heat welded together in one continuous process.

1.2 The products tested and covered by this Certificate are manufactured from material with the specification given in Table 1.

1.3 The outer wall is corrugated and the inner wall is smooth finished. Details and dimensions are given in Table 2 and Figure 1.

Table 2 Pipe dimensions

Nominal internal pipe diameter, $d_1$ (mm)	External pipe diameter, $d_2$ (mm)	$t_1$ min (mm)	$t_2$ min (mm)	$t_3$ min (mm)	Nominal length (m)	Nominal weight ( $\text{kgm}^{-1}$ )
150	177.3–180.3	1.0	2.2	1.0	6	1.50
225	267.0–270.0	1.0	2.8	1.3	6	3.75
300	353.0–356.0	1.3	2.8	1.5	6	6.00

Table 1 Material properties/specification<sup>(1)</sup>

Property	Test method reference	Specification
Tensile properties	EN 638, ISO 527-2	Sample at 50 mm min <sup>-1</sup> ≥ 20 MPa
Oxygen induction time	EN 728	≥ 8 min
Melt flow rate	ISO 1133	≤ 1.5 g (10 min) <sup>-1</sup> 2.16 kg at 190°C
Density	ISO 1183, ISO 4451	≥ 850 kgm <sup>-3</sup>
Heat reversion	ISO 12091	110°C ± 2°C (pass)
Effects of heating (injection moulded fittings only)	EN 763	N/A

(1) This table is in the format of Appendix 5/7 of MCHW, Volume 2. It is used to satisfy Clause 518.2 of MCHV, Volume 1.

Figure 1 Wavin Twin Wall pipe

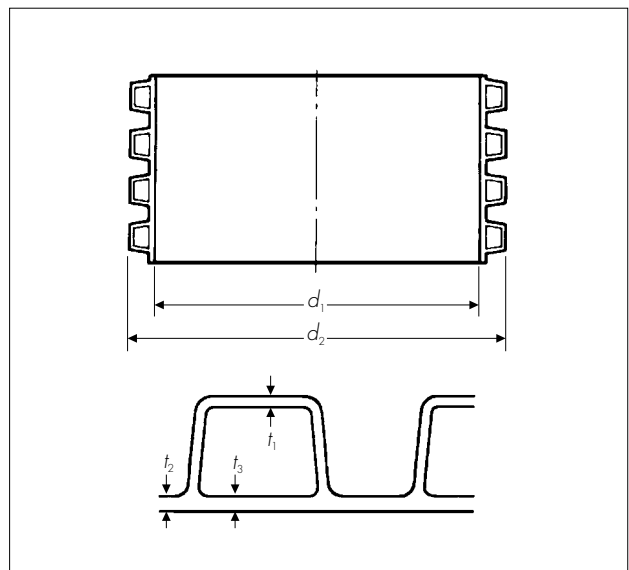

1.4 Black polypropylene couplers are available for each size of pipe (see Table 3 and Figure 2).

Table 3 Pipe coupler dimensions

Nominal pipe X (min) (mm)	Internal diameter, $d_3$ (min) (mm)	Nominal external diameter, $d_4$ (mm)	Nominal length (L) (mm)	Nominal seal height (h) (mm)
150	177.7	184.0	180	15
225	267.7	276.0	220	22
300	354.5	363.5	245	29

Figure 2 Pipe couplers

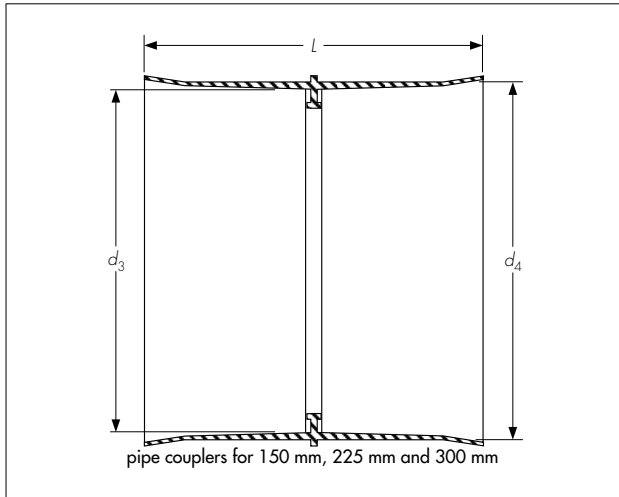

1.5 Seals manufactured to BS EN 681-1 : 1996 (see Figure 3) must be fitted in accordance with the installation instructions to ensure a watertight joint.

Figure 3 Seals

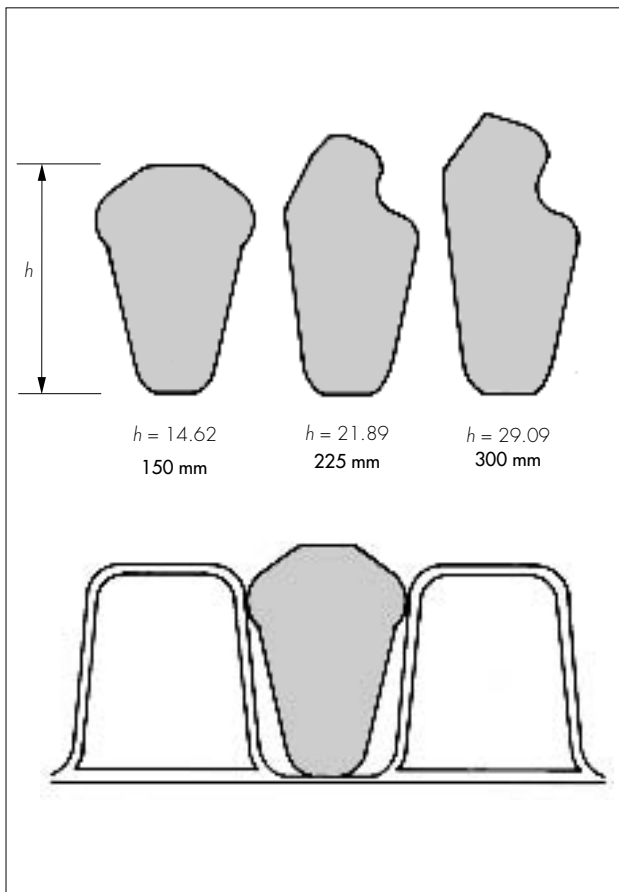

1.6 Pipes can be supplied either slotted or unslotted. Slotted pipe (see Table 4 and Figure 4) is available with four slots in each dwell between corrugations equally spaced around the circumference. Alternatively the pipes are supplied with three slots per dwell to provide a solid invert (half perforated pipe) with the permeable area reduced proportionally.

Table 4 Slotted pipe details

Nominal internal pipe diameter (mm)	No of slots per dwell	No of dwells length per metre	Slot length (mm)	Slot width (mm)	Permeable area (minimum) ( $\text{mm}^2\text{m}^{-1}$ )
150	4	51	15–20	2.0–2.5	6120
225	4	39	15–30	2.0–2.5	4680
300	4	32	20–40	2.0–2.5	5120

Figure 4 Details of slots

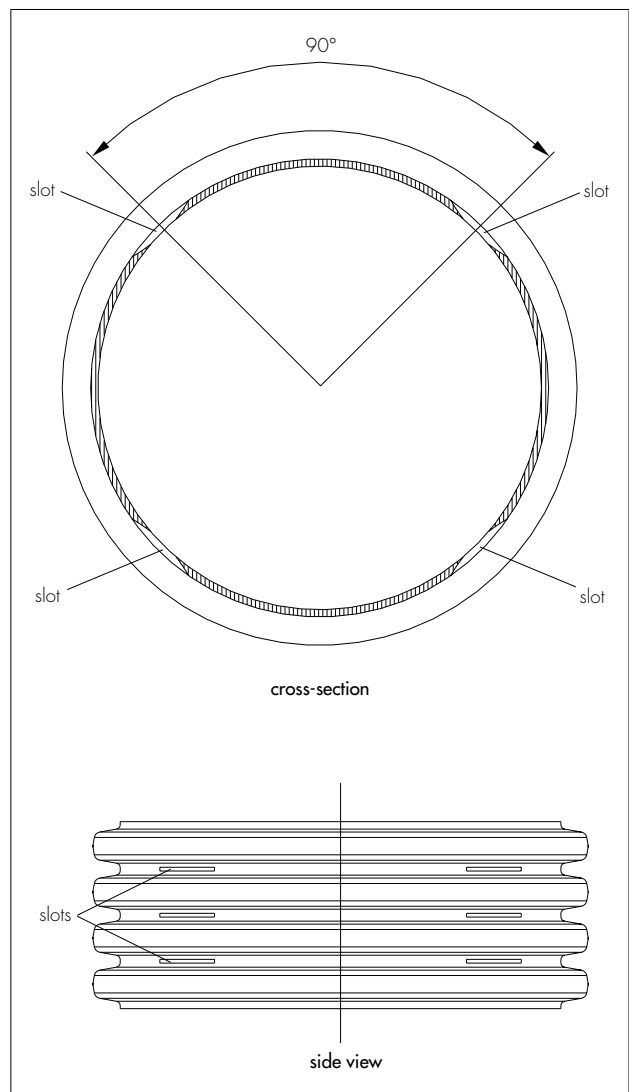

1.7 Continuous quality control is exercised during manufacture. Checks include:

*Pipes*

- dimensional accuracy
- visual
- marking
- impact resistance
- weight

# Electronic Copy

## Couplers

- dimensional accuracy
- marking.

1.8 The BBA identification mark incorporating the number of this Certificate is printed on each pipe length or printed on a label for each pack of couplers.

## 2 Delivery and site handling

2.1 Handling, storage and transportation should be in accordance with MCHW, BS 5955-6 : 1980 and manufacturer's instructions.

2.2 When long-term storage is envisaged, Wavin Twin Wall slotted and unslotted filter and carrier pipes and couplings must be protected from direct sunlight. If protection cannot be provided, consideration must be given to the effects of daily exposure to direct sunlight:

- up to 3 months — negligible UV degradation but possible extreme surface temperatures of up to 80°C may cause some localised distortion
- 3 to 12 months — may have significant effect on the impact resistance and physical properties
- over 12 months — damage will occur unless protection provided.

2.3 Pipes should be suitably supported at a minimum of two places when being lifted. Protected swings should preferably be used, but if metal hooks or chains are used then padding should be placed between them and the pipes.

2.4 Pipes should be stored on a flat surface, free from sharp projections, stones or other protuberances. They are generally delivered in pre-packed bundles and should be retained in their packaging until installation. Care should be taken to avoid dropping the pipes on their ends, particularly during cold weather conditions.

## Design Data

### 3 General

Wavin Twin Wall slotted and unslotted filter and carrier pipes and couplings, comply with the requirements of the Highways Agency (HA) Manual of Contract Documents for Highway Works (MCHW), Volume 1, Clause 518.5 for pipe, Clause 518.6 for couplers and Clause 518.7 for the system. When installed in accordance with the recommendations given in this Certificate, they are suitable for use in highways for the collection and disposal of surface and sub-surface water.

### 4 Strength

4.1 The product has adequate strength to resist loads associated with installation and with subsequent use. The ring stiffness of the pipe

exceeds the minimum requirement of 6 kNm<sup>-2</sup> and has a creep ratio of less than 4.

4.2 For safe bedding-depth purposes the pipes may be assumed to have a stiffness of greater than 6 kNm<sup>-2</sup>.

4.3 The pipes have adequate resistance to impact loads to which they may have been subjected during installation and in service. Care should be taken during site handling and installation to avoid dropping the pipes on their ends, particularly during cold weather conditions.

### 5 Performance of joints

5.1 Joints on filter pipes made from pipe and couplers without the rubber seals are not partially watertight as defined in the MCHW, Volume 1, Clause 504.3.

5.2 Correctly made, the joints constructed from pipe and couplers with rubber seals remain watertight when subjected to deflection and distortion, and comply with the MCHW, Volume 1, Clauses 504.3 and 518.7 (see section 14).

### 6 Water infiltration

The slot area for the pipes exceeds the minimum requirement given in MCHW, Volume 1, Clause 518.3 of 1000 mm<sup>2</sup> per metre length.

### 7 Flow characteristics



7.1 The pipes will have normal flow characteristics associated with PVC-U pipes.

7.2 Full-bore velocity values are available from the *Table for the Hydraulic Design of Pipes, Sewers and Channels*, Volume 2, 7th Edition by H R Wallingford and D I H Barr. The values are based on the Colebrook-White equation. An appropriate value of roughness coefficient should be selected when designing the drainage system. For new pipes, a value of 0.006 mm is applicable, but for designs, a value of 0.6 mm is generally used.

### 8 Practicability of installation

The pipes are installed easily using traditional drain-laying methods in accordance with the HA requirements and Clauses 503, 505 and 518 of MCHW, Volume 1. The lengths in which the pipes are available and their lightness in weight are a significant advantage in handling and installation. Jointing of the pipes is achieved easily.

### 9 Resistance to chemicals

The pipes will be unaffected by those types and quantities of chemicals likely to be found in surface water.

## 10 Maintenance

10.1 The slots are designed to restrict the ingress of silt into the drains.

10.2 Access to the system for cleaning should be provided by conventional methods.

10.3 The system can be rodded easily using flexible drain rods. In common with other standard plastic drainage systems, toothed root cutters and rods with metal ferrules, as used with some mechanical clearing systems, could damage the pipes and couplers and should not be used.

10.4 Tests indicate that the pipes have adequate resistance to water cleansing using pressure jetting equipment (see section 14.1). It is recommended that low-pressure, high-volume systems are utilised in accordance with MCHW, Volume 1, Clause 520.

## 11 Durability



In the opinion of the BBA, when used in the context of this Detail Sheet, the material from which the pipes and couplers are manufactured will not significantly deteriorate and the anticipated life of the system will be in excess of 50 years.

## Installation

### 12 General

Wavin Twin Wall slotted and unslotted filter and carrier pipes and couplings must be installed in accordance with the HA requirements and Clauses 503, 505 and 518 of MCHW, Volume 1.

### 13 Procedures

13.1 For typical laying, trench and backfilling specification details reference should be made to Figure 5 and the MCHW, Volume 3, Drawing No F1 (Types T and S) and F2 (Types G, H and I).

13.2 Pipes are cut easily using conventional hand tools, and should be cut square between the corrugations.

13.3 For a watertight joint, the pipe ends and coupler should be cleaned and a rubber seal fitted externally between the first and second corrugation in the pipe. The inside of the coupler should be lubricated and the pipe pushed fully home to the central register either by hand, or using a lever if necessary.

13.4 Wavin Twin Wall slotted and unslotted pipes and couplings must be protected against damage from site construction traffic.

13.5 Care should be taken during backfill to maintain the line and level of the pipeline. If necessary, the pipe should be restrained to prevent uplift.

Figure 5 Installation details

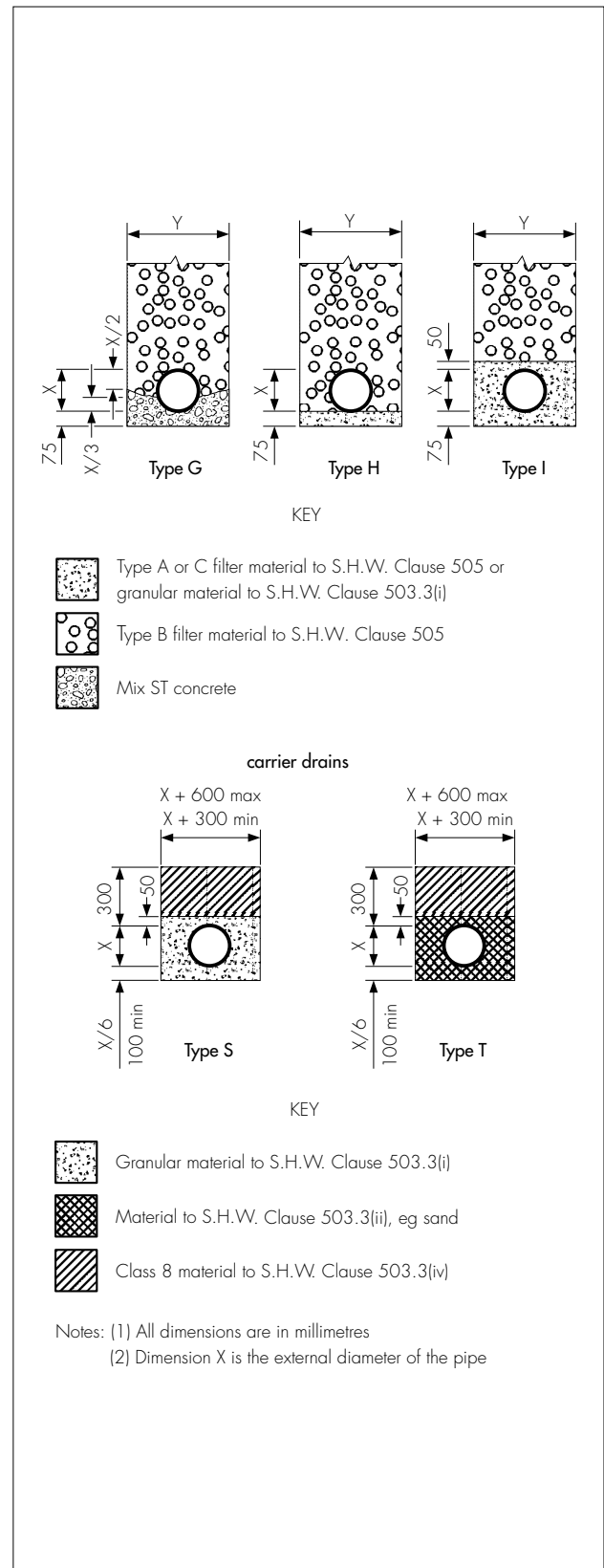

## Technical Investigations

The following is a summary of the technical investigations carried out on Wavin Twin Wall, High Density, Polyethylene Filter and Carrier Pipes, (with Internal Pipe Diameters of 150 mm, 225 mm and 300 mm), Ring Seals and Couplings.

### 14 Tests

14.1 Tests were carried out on the pipe to determine compliance with MCHW, Volume 1, Clause 518.5 on:

- determination of ring stiffness to BS EN ISO 9969 : 1995
- creep ratio to BS EN ISO 9967 : 1995
- resistance to longitudinal bending to MCHW, Volume 1, Clause 518.11
- impact strength at 0°C and 23°C to BS EN 1411 : 1996 with a d25 striker of 1.0 kg mass
- rodding resistance to MCHW, Volume 1, Clause 518.12
- water jetting WRc method.

14.2 Tests were carried out on joined pipe to establish compliance with MCHW, Volume 1, Clause 518.7 on:

- leaktightness of joints to BS EN 1277 : 1996 when subjected to diameter distortion and angular deflection from 0.5 bar to -0.3 bar
- insertion force (ease of jointing)
- resistance to rodding.

14.3 Tests were carried out to establish the dimensional accuracy of the pipe, coupler and ring seal to ISO 11922-1 : 1997.

### 15 Investigations

15.1 An examination was made of data in relation to the affect of the production tolerances on the performance of the products.

15.2 An evaluation of existing data was made to assess material properties, chemical resistance and durability.

15.3 Calculations were carried out to determine the slot area.

15.4 The manufacturing process was examined, including the methods adopted for quality control, and details were obtained of the quality and composition of the materials used.

## Bibliography

BS 5955-6 : 1980 *Plastics pipework (thermoplastics materials) — Code of practice for the installation of unplasticized PVC pipework for gravity drains and sewers*

BS EN 681-1 : 1996 *Elastomeric seals — Material requirements for pipe joint seals used in water and drainage applications — Vulcanized rubber*

BS EN 1277 : 1996 *Methods of testing plastics — Thermoplastics pipes, fittings and valves — Plastics piping systems — Thermoplastics piping systems for buried non-pressure applications — Test methods for leaktightness of elastomeric sealing ring type joints*

BS EN 1411 : 1996 *Plastics piping and ducting systems — Thermoplastics pipes — Determination of resistance to external blows by the staircase method*

BS EN ISO 9967 : 1995 *Thermoplastics pipes — Determination of creep ratio*

BS EN ISO 9969 : 1995 *Thermoplastics pipes — Determination of ring stiffness*

EN 638 : 1994 *Plastics piping and ducting systems — Thermoplastics pipes — Determination of tensile properties*

EN 728 : 1997 *Plastics piping and ducting systems — Polyolefin pipes and fittings — Determination of oxidation induction time*

EN 763 : 1994 *Plastics piping and ducting systems — Injection moulded thermoplastics fittings — Test method for visually assessing effects of heating*

ISO 527-2 : 1993 *Plastics — Determination of tensile properties — Test conditions for moulding and extrusion plastics*

ISO 1133 : 1997 *Plastics — Determination of the melt mass-flow rate (MFR) and the melt volume-flow rate (MVR) of thermoplastics*

ISO 1183 : 1987 *Plastics — Method for determining the density and relative density of non-cellular plastics*

ISO 4451 : 1980 *Polyethylene (PE) pipes and fittings — Determination of reference density of uncoloured and black polyethylenes*

ISO 11922-1 : 1997 *Thermoplastics pipes for the conveyance of fluids — Dimensions and tolerances — Metric series*

ISO 12091 : 1995 *Structural wall thermoplastics pipes — Oven test*

Manual of Contract Documents for Highway Works, Volume 1 *Specification for Highway Works*, August 1998 (as amended)

Manual of Contract Documents for Highway Works, Volume 2 *Notes for Guidance on the Specification for Highway Works*, August 1998 (as amended)

Manual of Contract Documents for Highway Works, Volume 3 *Highway Construction Details*, March 1998 (as amended)



On behalf of the British Board of Agrément

Date of Second issue: 23rd February 2005

A handwritten signature in black ink, appearing to read 'P. C. Hewson'.

Chief Executive

\*Original Detail Sheet issued 10th July 2002. This amended version includes change of product dimensions.



# Electronic Copy

---

**British Board of Agrément**

P O Box No 195, Bucknalls Lane  
Garston, Watford, Herts WD25 9BA  
Fax: 01923 665301

©2005

e-mail: [mail@bba.star.co.uk](mailto:mail@bba.star.co.uk)  
website: [www.bbacerts.co.uk](http://www.bbacerts.co.uk)



For technical or additional information,  
contact the Certificate holder (see  
front page).  
For information about the Agrément  
Certificate, including validity and  
scope, tel: Hotline 01923 665400,  
or check the BBA website.



Wavin Plastics Ltd

**WAVIN TWIN WALL, POLYPROPYLENE FILTER AND CARRIER PIPES (WITH INTERNAL PIPE DIAMETERS OF 300 mm, 375 mm, 450 mm, 500 mm AND 600 mm), RING SEALS AND COUPLINGS**

Certificate No 02/3940

**DETAIL SHEET 3**

Second issue\*

## Product

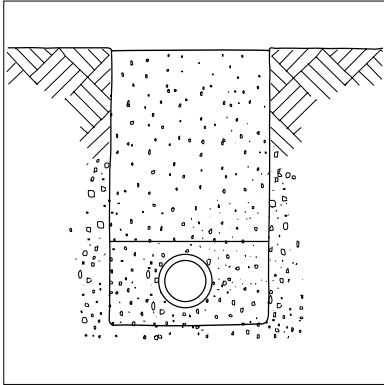

• THIS DETAIL SHEET RELATES TO WAVIN TWIN WALL, POLYPROPYLENE FILTER AND CARRIER PIPES (WITH INTERNAL PIPE DIAMETERS OF 300 mm, 375 mm, 450 mm, 500 mm AND 600 mm), RING SEALS AND COUPLINGS.

• The pipes, ring seals and couplings are for use in highway drainage for the collection and disposal of surface and sub-surface water.

This Detail Sheet must be read in conjunction with the Front Sheets, which give the product's position regarding the Building Regulations and the Conditions of Certification.

## Technical Specification

### 1 Description

1.1 Wavin Twin Wall filter and carrier (slotted and unslotted) pipes are manufactured in black polypropylene by a twin extrusion process. Two polypropylene pipes are extruded simultaneously, one inside the other, and heat welded together in one continuous process. Pipes are available plain ended or with integral sockets.

1.2 The products tested and covered by this Certificate are manufactured from material with the specification given in Table 1.

Table 1 Material properties/specification<sup>(1)</sup>

Property	Test method reference	Specification
Tensile properties	EN 638, ISO 527-2	Sample at 50 mm min <sup>-1</sup> ≥ 20 MPa
Oxygen induction time	EN 728	≥ 8 min
Melt flow rate	ISO 1133	≤ 1.5 g (10 min <sup>-1</sup> ) 2.16 kg at 230°C
Density	ISO 1183, ISO 4451	≥ 850 kgm <sup>-3</sup>
Heat reversion	ISO 12091	150°C ± 2°C (pass)
Effects of heating (injection moulded fittings only)	EN 763	N/A

(1) This table is in the format of Appendix 5/7 of MCHW, Volume 2. It is used to satisfy Clause 518.2 of MCHW, Volume 1.

1.3 The outer wall is corrugated and the inner wall is smooth finished. Details and dimensions are given in Table 2 and Figure 1.

Table 2 Pipe dimensions

Nominal internal pipe diameter, $d_1$ (mm)	External pipe diameter, $d_2$ (mm)	$t_1$ min (mm)	$t_2$ min (mm)	$t_3$ min (mm)	Nominal length (m)	Nominal weight ( $\text{kgm}^{-1}$ )	Integral socket	
							diameter (mm)	length (mm)
300	353.0–356.0	1.3	2.8	1.3	6	6.0	—	—
375	426.5–430.5	1.2	2.0	1.3	6	5.8	431.8–433.2	155–165
450	511.5–516.5	1.6	4.1	2.1	6	9.5	518.2–519.8	180–190
500	569.1–574.7	1.5	4.0	2.6	6	10.4	575.3–577.3	185–195
600	679.5–686.1	1.8	5.2	2.7	6	16.6	686.0–690.0	185–195

Figure 1 Wavin Twin Wall pipe

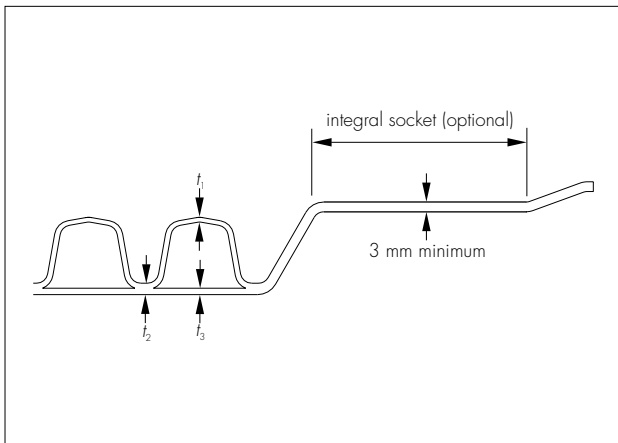

1.4 Black polypropylene pipe couplers are available for each size of pipe (see Table 3 and Figure 2).

Table 3 Pipe coupler dimensions

Nominal pipe size (mm)	Internal diameter (min) (mm)	Nominal external diameter, $d_4$ (mm)	Nominal length (L) (mm)	Nominal seal height (h) (mm)
300	354.5	363.5	245	29.0
375	431.8	442	325	32.6
450	518.2	530	405	39.4
500	573.3	589	460	44.2
600	686.8	704	640	50.8

Figure 2 Pipe coupler

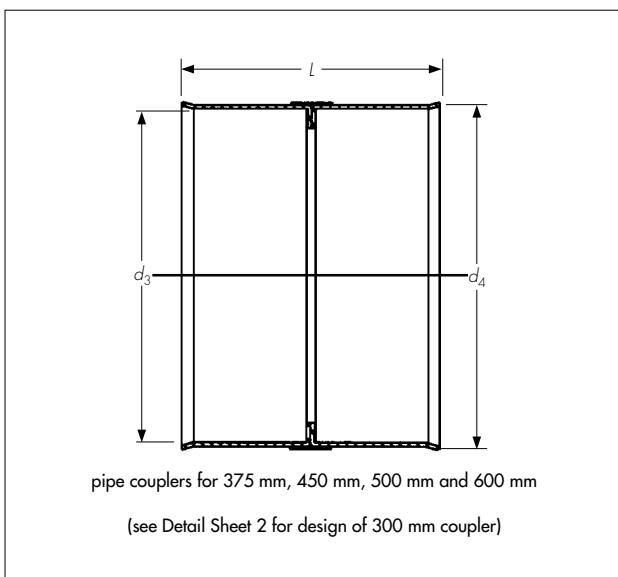

1.5 Seals manufactured to BS EN 681-1 : 1996 (see Figure 3) must be fitted in accordance with the installation instructions to ensure a watertight joint.

Figure 3 Seals

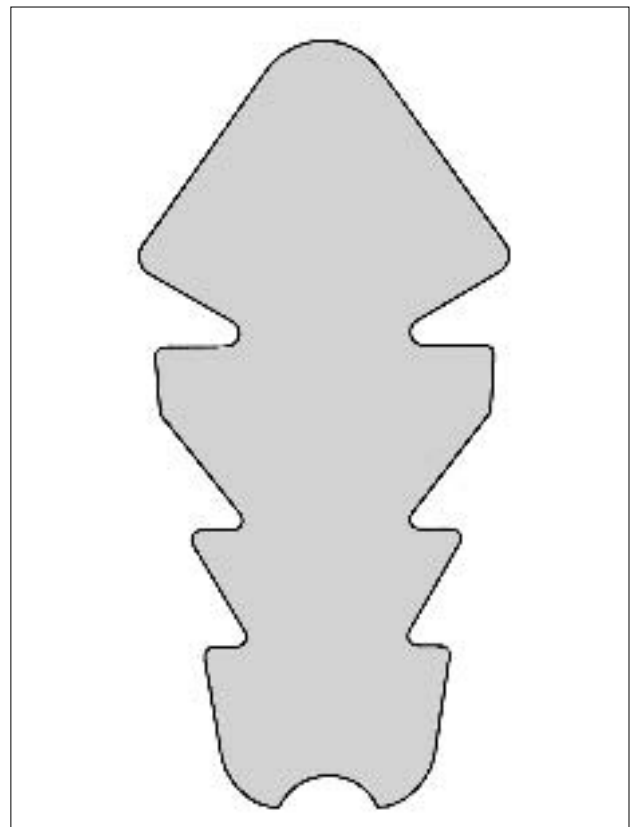

1.6 Pipes can be supplied either slotted or unslotted. Slotted pipe (see Table 4 and Figure 4) is available with the slots in the dwell between corrugations equally spaced around the circumference. Alternatively, the slots are located on one half only of the pipe and thus the number of slots per corrugation root (dwell) and the permeable area is halved.

Table 4 Slotted pipe details

Nominal internal pipe diameter (mm)	No of slots per dwell	No of dwells per metre	Slot length (mm)	Slot width (mm)	Permeable area (min) ( $\text{mm}^2\text{m}^{-1}$ )
300	4	30	20	2.5	4480
375	4	25	20	3.5	6266
450	4	20	25	3.5	6327
500	4	17	30	3.5	6687
600	4	15	35	3.5	6747

Figure 4 Details of slots

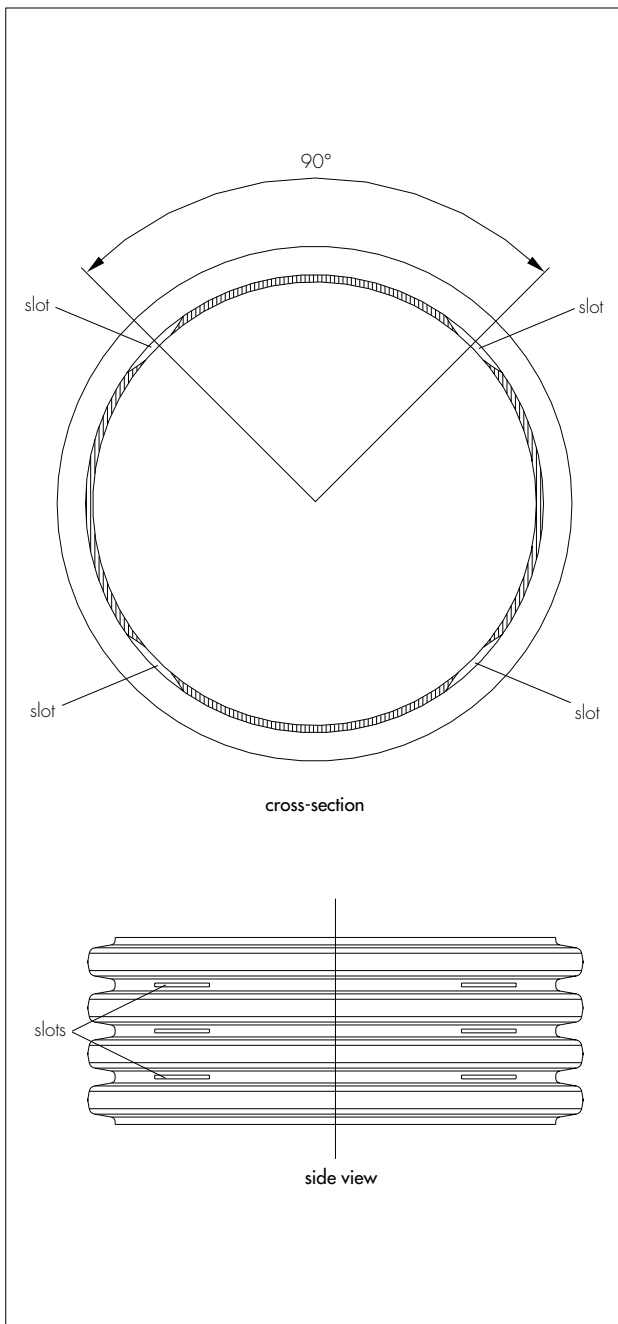

1.7 Continuous quality control is exercised during manufacture. Checks include:

#### Pipes

- dimensional accuracy
- visual
- marking
- impact resistance
- weight

#### Couplers

- dimensional accuracy
- marking.

1.8 The BBA Certificate number is printed on each pipe length or printed on a label for each pack of couplers in the size range of from 375 mm to 600 mm.

## 2 Delivery and site handling

2.1 Handling, storage and transportation should be in accordance with MCHW, manufacturer's instructions, and BS 5955-6 : 1980.

2.2 When long-term storage is envisaged, Wavin Twin Wall slotted and unslotted filter and carrier pipes and couplings must be protected from direct sunlight. If protection cannot be provided, consideration must be given to the effects of daily exposure to direct sunlight:

- up to 3 months — negligible UV degradation but possible extreme surface temperatures of up to 80°C may cause some localised distortion
- 3 to 12 months — may have significant effect on the impact resistance and physical properties
- over 12 months — damage will occur unless protection provided.

2.3 Pipes should be suitably supported at a minimum of two places when being lifted. Protected slings should preferably be used, but if metal hooks or chains are used then padding should be placed between them and the pipes.

2.4 Pipes should be stored on a flat surface, free from sharp projections, stones or other protuberances. They are generally delivered in pre-packed bundles and should be retained in the packing until installation. Care should be taken to avoid dropping the pipes on their ends, particularly during cold weather conditions.

## Design Data

### 3 General

Wavin Twin Wall slotted and unslotted filter and carrier pipes and couplings, comply with the requirements of the Highways Agency (HA) Manual of Contract Documents for Highway Works (MCHW), Volume 1, Clause 518.5 for pipe, Clause 518.6 for couplers and Clause 518.7 for the system. When installed in accordance with the recommendations given in this Certificate, they are suitable for use in highways for the collection and disposal of surface and sub-surface water.

### 4 Strength

4.1 The product has adequate strength to resist loads associated with installation and with subsequent use. The ring stiffness of the pipe exceeds the minimum requirement of 6 kNm<sup>-2</sup> and has a creep ratio of less than 4.

4.2 For safe bedding-depth purposes the pipes may be assumed to have a stiffness of greater than 6 kNm<sup>-2</sup>.

4.3 The pipes have adequate resistance to impact loads to which they may have been subjected during installation and in service. Care should be taken during site handling and installation to avoid

dropping the pipes on their ends, particularly during cold weather conditions.

## 5 Performance of joints

5.1 Joints on filter pipes made from pipe and couplers without the rubber seals are not partially watertight as defined in the MCHW, Volume 1, Clause 504.3.

5.2 Correctly made, the joints constructed from pipe and couplers with rubber seals remain watertight when subjected to deflection and distortion, and comply with the MCHW, Volume 1, Clauses 504.3 and 518.7 (see section 14).

## 6 Water infiltration

The slot area for the pipes exceeds the HA minimum requirement of 1000 mm<sup>2</sup> per metre length.

## 7 Flow characteristics



7.1 The pipes will have normal flow characteristics associated with PVC-U pipes.

7.2 Full-bore velocity values are available from the *Table for the Hydraulic Design of Pipes, Sewers and Channels*, Volume 2, 7th Edition by H R Wallingford and D I H Barr. The values are based on the Colebrook-White equation. An appropriate value of roughness coefficient should be selected when designing the drainage system. For new pipes, a value of 0.006 mm is applicable, but for designs, a value of 0.6 mm is generally used.

## 8 Practicability of installation

The pipes are installed easily using traditional drain-laying methods in accordance with the HA

requirements and Clauses 503, 505 and 518 of MCHW, Volume 1. The lengths in which the pipes are available and their lightness in weight are a significant advantage in handling and installation. Jointing of the pipes is achieved easily.

## 9 Resistance of chemicals

The pipes will be unaffected by those types and quantities of chemicals likely to be found in surface water.

## 10 Maintenance

10.1 The slots are designed to restrict the ingress of silt into the drains.

10.2 Access to the system for cleaning should be provided by conventional methods.

10.3 The system can be rodded easily using flexible drain rods. In common with other standard plastic drainage systems, toothed root cutters and rods with metal ferrules, as used with some mechanical clearing systems, could damage the pipes and couplers and should not be used.

10.4 Tests indicate that the pipes have adequate resistance to water cleansing using pressure jetting equipment (see section 14.1). It is recommended that low-pressure, high-volume systems are utilised in accordance with MCHW, Volume 1, Clause 520.

## 11 Durability



In the opinion of the BBA, when used in the context of this Detail Sheet, the material from which the pipes and couplers are manufactured will not significantly deteriorate and the anticipated life of the system will be in excess of 50 years.

### 12 General

Wavin Twin Wall slotted and unslotted filter and carrier pipes and couplings must be installed in accordance with the HA requirements and Clauses 503, 505, 518.7 and 518.8 of MCHW, Volume 1.

### 13 Procedures

13.1 For typical laying, trench and backfilling specification details reference should be made to Figure 5 and the MCHW, Volume 3, Drawing No F1 (Types T and S) and F2 (Types G, H and I).

13.2 Pipes are cut easily using conventional hand tools, and should be cut square between the corrugations.

13.3 For a watertight joint, the pipe ends and coupler should be cleaned and a rubber seal fitted externally between the first and second corrugation in the pipe. The inside of the coupler should be lubricated and the pipe pushed fully home to the central register either by hand, or using a lever if necessary.

13.4 Wavin Twin Wall slotted and unslotted pipes and couplings must be protected against damage from site construction traffic.

13.5 Care should be taken during backfill to maintain the line and level of the pipeline. If necessary, the pipe should be restrained to prevent uplift.

Figure 5 Installation details

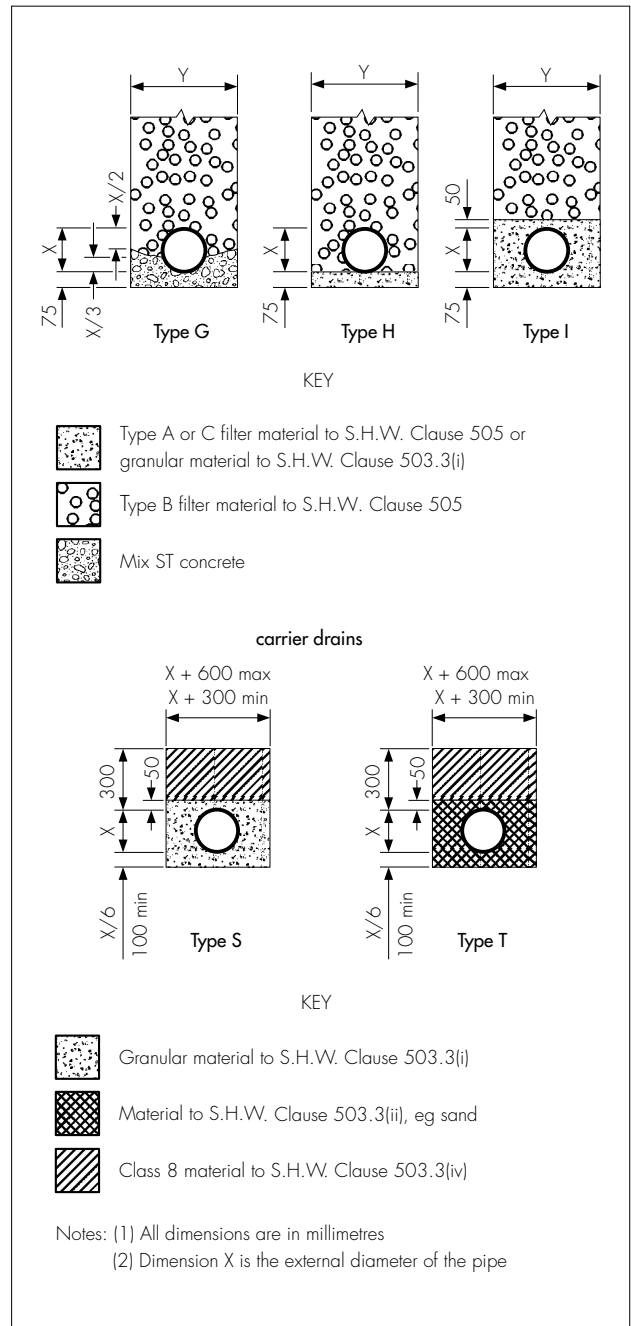

## Technical Investigations

The following is a summary of the technical investigations carried out on Wavin Twin Wall, Polypropylene Filter and Carrier Pipes, (with Internal Pipe Diameters of 300 mm, 375 mm, 450 mm, 500 mm and 600 mm) Ring Seals and Couplings.

### 14 Tests

14.1 Tests were carried out on the pipe to determine compliance with MCHW, Volume 1, Clause 518.5 on:

- determination of ring stiffness to BS EN ISO 9969 : 1995
- creep ratio to BS EN ISO 9967 : 1995
- resistance to longitudinal bending to MCHW, Volume 1, Clause 518.11
- impact strength at 0°C and 23°C to BS EN 1411 : 1996 with a d25 striker of 1.0 kg mass
- rodding resistance to MCHW, Volume 1, Clause 518.12
- water jetting WRc method.

14.2 Tests were carried out on joined pipe to establish compliance with MCHW, Volume 1, Clause 518.7 on:

- leaktightness of joints to BS EN 1277 : 1996 when subjected to diameter distortion and angular deflection from 0.5 bar to -0.3 bar
- insertion force (ease of jointing)
- resistance to rodding.

14.3 Tests were carried out to establish the dimensional accuracy of the pipe, coupler and ring seal to ISO 11922-1 : 1997.

### 15 Investigations

15.1 An examination was made of data in relation to the affect of the production tolerances on the performance of the products.

15.2 An evaluation of existing data was made to assess material properties, chemical resistance and durability.

15.3 Calculations were carried out to determine the slot area.

15.4 The manufacturing process was examined, including the methods adopted for quality control, and details were obtained of the quality and composition of the materials used.

## Bibliography

BS 5955-6 : 1980 *Plastics pipework (thermoplastics materials) — Code of practice for the installation of unplasticized PVC pipework for gravity drains and sewers*

BS EN 681-1 : 1996 *Elastomeric seals — Material requirements for pipe joint seals used in water and drainage applications — Vulcanized rubber*

BS EN 728 : 1997 *Plastics piping and ducting systems — Polyolefin pipes and fittings — Determination of oxidation induction time*

BS EN 1277 : 1996 *Methods of testing plastics — Thermoplastics pipes, fittings and valves — Plastics piping systems — Thermoplastics piping systems for buried non-pressure applications — Test methods for leaktightness of elastomeric sealing ring type joints*

BS EN 1411 : 1996 *Plastics piping and ducting systems — Thermoplastics pipes — Determination of resistance to external blows by the staircase method*

BS EN ISO 9967 : 1995 *Thermoplastics pipes — Determination of creep ratio*

BS EN ISO 9969 : 1995 *Thermoplastics pipes — Determination of ring stiffness*

EN 638 : 1994 *Plastics piping and ducting systems — Thermoplastics pipes — Determination of tensile properties*

EN 728 : 1997 *Plastics piping and ducting systems — Polyolefin pipes and fittings — Determination of oxidation induction time*

EN 763 : 1994 *Plastics piping and ducting systems — Injection moulded thermoplastics fittings — Test method for visually assessing effects of heating*

ISO 527-2 : 1993 *Plastics — Determination of tensile properties — Test conditions for moulding and extrusion plastics*

ISO 1133 : 1997 *Plastics — Determination of the melt mass-flow rate (MFR) and the melt volume-flow rate (MVR) of thermoplastics*

ISO 1183 : 1987 *Plastics — Method for determining the density and relative density of non-cellular plastics*

ISO 4451 : 1980 *Polyethylene (PE) pipes and fittings — Determination of reference density of uncoloured and black polyethylenes*

ISO 11922-1 : 1997 *Thermoplastics pipes for the conveyance of fluids — Dimensions and tolerances — Metric series*

ISO 12091 : 1995 *Structural wall thermoplastics pipes — Oven test*

Manual of Contract Documents for Highway Works, Volume 1 *Specification for Highway Works*, August 1998 (as amended)

Manual of Contract Documents for Highway Works, Volume 2 *Notes for Guidance on the Specification for Highway Works*, August 1998 (as amended)

Manual of Contract Documents for Highway Works, Volume 3 *Highway Construction Details*, March 1998 (as amended)



On behalf of the British Board of Agrément

Date of Second issue: 23rd February 2005

A handwritten signature in black ink, appearing to read 'P. C. Newson'.

Chief Executive

\*Original Detail Sheet issued 10th July 2002. This amended version includes change of pipe dimensions, specifications and change of seal profile.

# Electronic Copy

---

**British Board of Agrément**

P O Box No 195, Bucknalls Lane  
Garston, Watford, Herts WD25 9BA  
Fax: 01923 665301

©2005

e-mail: [mail@bba.star.co.uk](mailto:mail@bba.star.co.uk)  
website: [www.bbacerts.co.uk](http://www.bbacerts.co.uk)



For technical or additional information,  
contact the Certificate holder (see  
front page).  
For information about the Agrément  
Certificate, including validity and  
scope, tel: Hotline 01923 665400,  
or check the BBA website.



Wavin Plastics Ltd

WAVIN TWIN WALL  
JUNCTIONS AND BENDS

Certificate No 02/3940

DETAIL SHEET 4

## Product



- THIS DETAIL SHEET RELATES TO WAVIN TWIN WALL JUNCTIONS AND BENDS FOR USE IN HIGHWAY DRAINAGE.
- The fittings are for use with the pipes described in Detail Sheets 1 and 2 of this Certificate for the collection and disposal of surface and sub-surface water.

This Detail Sheet must be read in conjunction with the Front Sheets, which give the product's position regarding the Building Regulations and the Conditions of Certification.

## Technical Specification

### 1 Description

1.1 Wavin Twin Wall Junctions and Bends are manufactured from material with the specifications given in Tables 1 to 3.

1.2 Details and dimensions of the fittings are given in Table 4.

1.3 The ring seals are also described in Detail Sheets 2 and 3 are available for each size of pipe for connection to the fittings.

1.4 Continuous quality control is exercised during manufacture. Checks include:

dimensional accuracy  
airtightness  
visual examination.

1.5 Each fitting carries a label bearing the BBA identification mark incorporating the number of this Certificate, and the angle of the bends and junctions, and for fittings greater than 300 mm nominal diameter the legend 'Handle with Care'.

### 2 Delivery and site handling

2.1 Handling, storage and transportation should be in accordance with MCHW, BS 5955-6 : 1980 and the manufacturer's instructions.

2.2 When long-term storage is envisaged, Wavin Twin Wall slotted and unslotted filter and carrier pipes and couplings must be protected from direct sunlight. If protection cannot be provided,

consideration must be given to the effects of daily exposure to direct sunlight.

2.3 Fittings above 300 mm nominal diameter must be handled with care.

Table 1 Material properties/specification<sup>(1)</sup> PVC<sup>(2)</sup>

Property	Test method reference	Specification
Tensile properties	ISO 527-1	N/A
Vicat	EN 727	> 79°C
K value	EN 922	56-60
Density	ISO 1183, ISO 4451	≥ 600 kgm <sup>-3</sup>
Heat reversion	ISO 12091	N/A
PVC content	EN 1905	>80%
Effects of heating (injection moulded fittings only)	EN 763	150°C for 30 mins (pass)

(1) This table is in the format of Appendix 5/7 of MCHW, Volume 2. It is used to satisfy Clause 518.2 of MCHW, Volume 1.

(2) This covers, 150 mm fittings (injection moulded).

Table 2 Material properties/specification<sup>(1)</sup> PE<sup>(2)</sup>

Property	Test method reference	Specification
Tensile properties	ISO 527-1	Sample 1B @ 50 mm min <sup>-1</sup> ≥ 16 MPa
Oxygen induction time	EN 728	≥ 8 min
Melt flow rate	ISO 1133	≤ 6.0 g (10 min) <sup>-1</sup>
Density	ISO 1183, ISO 4451	≥ 934 kgm <sup>-3</sup>
Heat reversion	ISO 12091	N/A
Effects of heating (injection moulded fittings only)	EN 763	N/A

(1) This table is in the format of Appendix 5/7 of MCHW, Volume 2. It is used to satisfy Clause 518.2 of MCHW, Volume 1.

(2) This covers, 225 mm and 300 mm fittings (rotationally moulded).

**Table 3** Material properties/specification<sup>(1)PP<sup>2</sup></sup>

Property	Test method reference	Specification
Tensile properties	ISO 527-1	Sample 1B @ 50 mm min <sup>-1</sup> ≥ 28 MPa
Oxygen induction time	EN 728	≥ 8 min
Melt flow rate	ISO 1133	≤ 0.4 g (10 min) <sup>-1</sup>
Density	ISO 1183, ISO 4451	≥ 850 kgm <sup>-3</sup>
Heat reversion	ISO 12091	N/A
Effects of heating (injection moulded fittings only)	EN 763	N/A

(1) This table is in the format of Appendix 5/7 of MCHW, Volume 2. It is used to satisfy Clause 518.2 of MCHW, Volume 1.

(2) This covers, 375 mm, 450 mm, 500 mm and 600 mm fittings (fabricated).

**Table 4** Fittings

**Bends 87.5°, 45°, 30° and 15°**  
(150 mm – 300 mm D/S, 375 mm – 600 mm S/S)

150	450
225	500
300	600
375	



**Junctions 45°**  
(150 mm – 300 mm D/S, 375 mm – 600 mm S/S)

150 x 150	450 x 225
225 x 225	450 x 300
300 x 300	450 x 375
375 x 375	500 x 150
450 x 450	500 x 225
500 x 500	500 x 300
600 x 600	500 x 375
225 x 150	500 x 450
300 x 150	600 x 150
300 x 225	600 x 225
375 x 150	600 x 300
375 x 225	600 x 375
375 x 300	600 x 450
450 x 150	600 x 500



**Junctions 90°**

375 x 375	375 x 225
450 x 450	450 x 150
500 x 500	450 x 225
600 x 600	500 x 150
375 x 150	600 x 150



## Design Data

### 3 General

Wavin Twin Wall Junctions and Bends, when used with the pipes described in Detail Sheets 2 and 3 comply with the requirements of the Department for Transport, Local Government and the Regions, Highways Agency (DTLR, HA) Manual of Contract Documents for Highway Works (MCHW), Volume 1, Clause 518.3 for pipe, Clause 518.6 for couplers and Clause 518.7 for the system.

When installed in accordance with the recommendations given in the Certificate they are suitable for use in highways for the collection and disposal of surface and sub-surface water.

### 4 Strength

The fittings have adequate strength to resist loads associated with installation and with subsequent use in the situations described in this Detail Sheet.

### 5 Performance of joints

The joints constructed from connectors with rubber seals comply with watertight joints in accordance with MCHW, Volume 1, sub-clause 504.3.

### 6 Flow characteristics

When used with the pipes described in Detail Sheet 3, the fittings will increase the hydraulic resistance of the system. Loss coefficients (K values) may be taken as:

11° bends	0.2
22° and 45° bend	0.5
45° branch connections	1.0

### 7 Practicability of installation

The fittings are installed easily using conventional drain-laying techniques (see section 11).

### 8 Maintenance

Drains incorporating the fittings can be rodded easily using conventional drain rods. In common with other standard plastics drainage systems, toothed root cutters and rods with metal ferrules, as used with some mechanical cleaning systems, could damage the fittings and should not be used.

### 9 Durability

Wavin Twin Wall fittings can be expected to have a life equivalent to that of other plastics fittings listed in Table 5/1 of MCHW, Volume 1.

## Installation

### 10 General

Drains utilising the fittings must be installed in accordance with MCHW, Volume 1, Clauses 503, 505, 518.7 and 518.8.

### 11 Procedure

11.1 For typical laying, trench and backfilling specification details, see section 13 of Detail Sheets 2 and 3.

11.2 To make a joint a ring seal is fitted externally to the first corrugation in the pipe. The inside of the coupler is lubricated and the pipe pushed fully home to the central register.

11.3 Pipes and fittings must be protected from site construction traffic.

## Technical Investigations

The following is a summary of the technical investigations carried out on Wavin Twin Wall Junctions and Bends.

### 12 Tests

Tests were carried out to determine:  
dimensional accuracy to ISO 11922-1 : 1997  
and ISO 11922-2 : 1997  
impact resistance (drop test) to BS EN 12061 :  
1999  
ring stiffness to ISO 13967 : 1998  
rodding resistance to sub-clause 518.12  
watertightness of fabricated fittings to EN 1053 :  
1995.

### 13 Other investigations

The manufacturing process was examined, including the methods adopted for quality control, and details were obtained of the quality and composition of the materials used.

## Bibliography

BS EN 12061 : 1999 *Plastics piping systems — Thermoplastics fittings — Test method for impact resistance*  
EN 727 : 1994 *Plastics piping and ducting systems — Thermoplastics pipes and fittings — Determination of Vicat softening temperature (VST)*  
EN 728 : 1997 *Plastics piping and ducting systems — Polyolefin pipes and fittings — Determination of oxidation induction time*  
EN 763 : 1994 *Plastics piping and ducting systems — Injection moulded thermoplastics fittings — Test method for visually assessing effects of heating*  
EN 922 *Plastics piping and ducting systems — Pipes and fittings of unplasticized poly(vinyl chloride) (PVC-U) — Specimen preparation for determination of the viscosity number and calculation of the K-value*

EN 1053 : 1995 *Plastics piping systems — Thermoplastics piping systems for non-pressure applications — Test method for watertightness*  
EN 1905 *Plastics piping systems — Unplasticized poly (vinyl chloride) (PVC-U) pipes, fittings and material — Method for assessment of the PVC content based on total chlorine content*  
ISO 527-1 : 1993 *Plastics — Determination of tensile properties — General principles*  
ISO 1133 : 1997 *Plastics — Determination of the melt mass-flow rate (MFR) and the melt volume-flow rate (MVR) of thermoplastics*  
ISO 1183 : 1987 *Plastics — Method for determining the density and relative density of non-cellular plastics*  
ISO 4451 : 1980 *Polyethylene (PE) pipes and fittings — Determination of reference density of uncoloured and black polyethylenes*  
ISO 12091 : 1995 *Structural wall thermoplastics pipes — Oven test*  
ISO 11922-1 : 1997 *Thermoplastic pipes for the conveyance of fluids — Dimensions and tolerances — Metric series*  
ISO 11922-2 : 1997 *Thermoplastic pipes for the conveyance of fluids — Dimensions and tolerances — Inch-based series*

ISO 13967 : 1998 *Thermoplastic fittings — Determination of ring stiffness*  
Manual of Contract Documents for Highway Works, Volume 1 : *Specification for Highway Works* : May 2001 edition  
Manual of Contract Documents for Highway Works, Volume 2 : *Notes for Guidance on the Specification for Highway Works* : 2001



On behalf of the British Board of Agrément

Date of issue: 10th July 2002

A handwritten signature in black ink, appearing to read 'P. C. Hewitt', is positioned above the title 'Chief Executive'.

Chief Executive

# Electronic Copy

---

**British Board of Agrément**  
P O Box No 195, Bucknalls Lane  
Garston, Watford, Herts WD25 9BA  
Fax: 01923 665301

©2002

e-mail: [mail@bba.star.co.uk](mailto:mail@bba.star.co.uk)  
website: [www.bbacerts.co.uk](http://www.bbacerts.co.uk)



For additional information about the Certificate, tel: 01923 665300.  
For information about Agrément Certificate validity and scope, tel: Hotline 01923 665400, or check the BBA website.