



Wavin Building Products Ltd

Parsonage Way
Chippenham
Wilts SN15 5PN
Tel: 01249 654121 Fax: 01249 443286

**Agrément
Certificate
No 87/1835**
Second issue*

Designated by Government
to issue
European Technical
Approvals

OSMADRAIN UNDERGROUND DRAINAGE SYSTEM

Eléments de drainage souterrains
Dränungssystem

Product



• THIS CERTIFICATE RELATES TO THE OSMADRAIN 110 mm AND 160 mm UNDERGROUND DRAINAGE SYSTEM, THE COMPONENTS OF WHICH ARE REFERRED TO IN THE ACCOMPANYING DETAIL SHEETS.

- The system is for use in domestic drains and public and private sewers.
- Components of the system can be used individually or in combinations as described in the Detail Sheets.
- This Certificate does not cover the use of any of the products for untreated trade effluents.

Building Regulations — Detail Sheet 1

1 The Building Regulations 1991 (as amended) (England and Wales)

The Secretary of State has agreed with the British Board of Agrément the aspects of performance to be used by the BBA in assessing the compliance of drainage systems with the Building Regulations. In the opinion of the BBA, the OsmoDrain Underground Drainage System, if used in accordance with the provisions of this Certificate, will meet the relevant requirements.

Requirement: H1(1)	Sanitary pipework and drainage
Comment:	See the marked sections of the <i>Design Data</i> parts in the accompanying Detail Sheets.
Requirement: H3	Rainwater drainage
Comment:	See the marked sections of the <i>Design Data</i> parts in the accompanying Detail Sheets.
Requirement: Regulation 7	Materials and workmanship
Comment:	The system is acceptable.

Electronic Copy

2 The Building Standards (Scotland) Regulations 1990 (as amended)



In the opinion of the BBA, the OsmaDrain Underground Drainage System, if used in accordance with the provisions of this Certificate, will satisfy the various Regulations as listed below.

Regulation:	10	Selection and use of materials and components
Standards:	B2.1, B2.2	Selection and use of materials and components
Comment:		The system is acceptable.
Standard:	M2.1	Drainage system of a building
Comment:		The system can meet the relevant requirements of this Standard. See the marked sections of the <i>Design Data</i> parts in the accompanying Detail Sheets.

3 The Building Regulations (Northern Ireland) 1994 (as amended)



In the opinion of the BBA, the OsmaDrain Underground Drainage System, if used in accordance with the provisions of this Certificate, will satisfy the various Regulations as listed below.

Regulation:	B2	Fitness of materials and workmanship
Comment:		The system is acceptable.
Regulation:	Part N2	Drainage, systems
Comment:		The system satisfies the relevant requirements of this Regulation. See the marked sections of the <i>Design Data</i> parts in the accompanying Detail Sheets.

Conditions of Certification

4 Conditions

4.1 This Certificate:

- (a) relates only to the product that is described, installed, used and maintained as set out in this Certificate;
- (b) is granted only to the company, firm or person identified on the front cover — no other company, firm or person may hold or claim any entitlement to this Certificate;
- (c) is copyright of the BBA.

4.2 References in this Certificate to any Act of Parliament, Regulation made thereunder, Directive or Regulation of the European Union, Statutory Instrument, Code of Practice, British Standard, manufacturers' instructions or similar publication, shall be construed as references to such publication in the form in which it was current at the date of this Certificate.

4.3 This Certificate will remain valid for an unlimited period provided that the product and the manufacture and/or fabricating process(es) thereof:

- (a) are maintained at or above the levels which have been assessed and found to be satisfactory by the BBA;
- (b) continue to be checked by the BBA or its agents; and

(c) are reviewed by the BBA as and when it considers appropriate.

4.4 In granting this Certificate, the BBA makes no representation as to:

- (a) the presence or absence of any patent or similar rights subsisting in the product or any other product;
- (b) the right of the Certificate holder to market, supply, install or maintain the product; and
- (c) the nature of individual installations of the product, including methods and workmanship.

4.5 Any recommendations relating to the use or installation of this product which are contained or referred to in this Certificate are the minimum standards required to be met when the product is used. They do not purport in any way to restate the requirements of the Health & Safety at Work etc Act 1974, or of any other statutory, common law or other duty which may exist at the date of this Certificate or in the future; nor is conformity with such recommendations to be taken as satisfying the requirements of the 1974 Act or of any present or future statutory, common law or other duty of care. In granting this Certificate, the BBA does not accept responsibility to any person or body for any loss or damage, including personal injury, arising as a direct or indirect result of the installation and use of this product.



In the opinion of the British Board of Agrément, the OsmaDrain Underground Drainage System is fit for its intended use provided it is installed, used and maintained as set out in this Certificate. Certificate No 87/1835 is accordingly awarded to Wavin Building Products Ltd.

On behalf of the British Board of Agrément

Date of Second issue: 24th December 1998

Director

**Original Certificate issued 29th April 1987, this revised version issued to include updated telephone number, the facsimile number, reference to the revised national Building Regulations and new Conditions of Certification.*

Electronic Copy

British Board of Agrément
P O Box No 195, Bucknalls Lane
Garston, Watford, Herts WD2 7NG
Fax: 01923 665301

©1999

e-mail: mail@bba.star.co.uk
<http://www.bbacerts.co.uk>



For technical or additional
information, tel: 01923 665300.
For information about Agrément
Certificate validity and scope, tel:
Hotline: 01923 665400



Wavin Building Products Ltd

Certificate No 87/1835

OSMADRAIN UNDERGROUND DRAINAGE SYSTEM

DETAIL SHEET 2

BSI Kitemarked Components

• THIS DETAIL SHEET LISTS THE COMPONENTS IN THE OSMADRAIN UNDERGROUND DRAINAGE SYSTEM CURRENTLY COVERED BY THE BSI KITEMARK CERTIFICATION SCHEME.



BSI Kitemark Licence No 7091 issued to

Wavin Building Products Ltd,
Parsonage Way,
Chippenham,
Wilts SN15 5PN.

BSI Kitemark Licence No 5452 issued to

Wavin Building Products Ltd,
Cobbs Wood,
Ashford,
Kent TN23 1EL.

BSI Kitemark Licence No 6000 issued to

Wavin Industrial Products Ltd,
Meadowfield Industrial Estate,
Brandon, Durham DH7 8RJ.

BS 4660 : 1973 Specification for unplasticized PVC underground drain pipe and fittings — Nominal sizes of 110 mm and 160 mm. Materials, material colour, dimensions, marking, sampling and tests on pipe, fittings and assemblies. Notes for guidance on storage, handling and installation.

Kitemark certified pipe and fittings to BS 4660 : 1973*	Manufacturer's catalogue No**	Nominal size (mm)
Plain ended pipe	3m	4D 073/A/B/C
	6m	4D 076/A/B/C
	3m	6D 073/A/B/C
	6m	6D 076/A/B/C
D/S pipe coupler	4D 205/A	110
	6D 205/A	160
S/SW pipe coupler	4D 124/A	110
	6D 124/A	160
D/S slip coupler	4D 105/A	110
	6D 105/A	160
S/S adaptor to cast iron or clay socket	4D 107/A	110
	6D 107/A	110
S/S adaptor to cast iron or clay spigot	4D 128/A	110
	6D 128/A	160
SS reducer	4D 095/A	110 x 82
	6D 099/A	160 x 110
S/S 1 1/2° short radius bend	4D 168/B	110
S/S 15° short radius bends	4D 167/A	110
	6D 167/A	160
S/S 30° short radius bends	4D 166/A	110
	6D 166/A	160
S/S 45° short radius bends	4D 163/A	110
	6D 163/A	160
S/S 67 1/2° short radius bends	4D 162/A	110
S/S 87 1/2° short radius bends	4D 161/A	110
	6D 161/A	160
D/S 1 1/4° short radius bends	4D 568/B	110
D/S 15° short radius bends	4D 567/A	110
	6D 567/A	160
D/S 30° short radius bends	4D 566/A	110
	6D 566/A	160
D/S 45° short radius bends	4D 563/A	110
	6D 563/A	160
D/S 67 1/2° short radius bends	4D 562/A	110
D/S 87 1/2° short radius bends	4D 561/A	110
	6D 561/A	160
S/S 45° long radius bends	4D 183/A	110
	6D 183/A	160
D/S 45° long radius bends	4D 583/A	110
	6D 583/A	160
D/S 87 1/2° long radius test bend	4D 581/A	110

continued

Electronic Copy

continued

S/S 87½° long radius bend	4D 181/D	110
P/E 90° long radius bend	6D 281/A	160
S/S 45° equal junctions	4D 210/A	110
	6D 210/A	160
S/S 45° unequal junctions	6D 218/A	160 x 100
S/S 87½° equal junctions	4D 190/A	110
	6D 190/A	160
S/S 87½° unequal junctions	6D 198/A	160 x 100
D/S 45° equal junctions	4D 213/A	110
	6D 213/A	160
D/S 45° unequal junctions	6D 219/A	160 x 110
D/S 87½° equal junctions	4D 193/A	110
	6D 193/A	160
S/S inspection pipes	4D 420/B	110
	6D 420/D	160
S/S equal single inspection junctions	4D 441/B	110
	4D 451/B	110
	6D 441/D	160
	6D 451/D	160
S/S 45° equal double inspection junction	6D 492/D	160
D/S inspection pipes	4D 520/B	110
	6D 520/D	160
D/S 45° equal single inspection junctions	4D 541/C	110
	4D 551/C	110
	6D 541/D	160
	6D 551/D	160
D/S 45° equal double inspection junctions	4D 592/C	110
	6D 592/D	160
D/S 45° equal twin inspection junctions	4D 542/D	110
	4D 552/D	110
D/S 45° equal double twin inspection junction	4D 594/D	110
S/S 87½° short radius access bend with screwed access	4D 169/A	110
D/S 87½° short radius access bend with screwed access	4D 569/A	110
S/S access pipe	6D 274/A	160
S/S screwed access covers	4D 292/A	110
	6D 292/A	160
Socket plugs	4D 296/A	110
D/S 87½° equal single access junction	4D 593/A	110
S/S 15° channel branch bends	6D 776/D	160
	6D 777/D	160
S/S 30° channel branch bends	6D 778/D	160
	6D 779/D	160
S/S 45° channel branch bends	6D 780/D	160
	6D 781/D	160
S/S 87½° channel branch bends	6D 784/D	160
	6D 785/D	160
SW/½S 45° equal channel junctions	4D 794/D	110
	4D 795/D	110
SW/½S 87½° equal channel junctions	4D 792/D	110
	4D 793/D	110
SW/½S 45° unequal channel junctions	6D 798/D	160 x 110
	6D 799/D	160 x 110
SW/½S 87½° unequal channel junctions	6D 796/D	160 x 110
	6D 797/D	160 x 110
SW/½S half connectors	4D 864/D	110
	6D 864/D	160
SW/½S access pipes	4D 868/D	110
	6D 868/D	160
P/E channel access pipes	4D 874/D	110
	6D 874/D	160
D/S 90° channel bends	4D 585/D	110
	6D 585/D	160

continued

Electronic Copy

continued

D/S 45° long radius	4D 587/D	110
channel bends	6D 587/D	160
Socket plug with open boss socket	4D 297/D	110
S/S screwed access cover	4D 290/B	110
S/S screwed access cover	6D 290/B	160
S/S adjustable bend — LH	4D 782/B	110
S/S adjustable bend — RH	4D 783/B	110
D/S unequal junction 87½°	6D 199/A	160



BS 497 : Part 1 : 1976 Specification for manhole covers, road gully gratings and frames for drainage purposes — Cast iron and cast steel

— Materials, workmanship, protective coating, quality control, inspection, marking, grading, dimensions and design features.

Appendices detail loading tests and summarize optional variations.

Kitemark certified pipe and fittings to BS 497 : Part 1 : 1976*	Manufacturer's catalogue No**	Nominal size (mm)
Cast iron cover and frame — single seal	4D 344/E	110
Cast iron cover and frame — double seal	4D 346/E	110

BSI Kitemark Licence No 7133 issued to

Brickhouse Dudley Manufacturing (Fareham) Ltd, 2 Quay Street, Fareham, Hampshire PO16 0LP.



BS 4514 : 1983 Specification for unplasticized PVC soil and ventilating pipes, fittings and accessories — Applies to unplasticized PVC soil and ventilating pipe, fittings and accessories, including coated metal fittings, and jointing materials for use in above ground drainage systems intended to convey normal domestic effluents and surface rainwater.

Kitemark certified pipe and fittings to BS 4514 : 1983*	Manufacturer's catalogue No**
P/E 90° WC connector with access	4D 761/F
SW/S 90° WC connector with access	4D 762/F

BSI Kitemark Licence No 5314 issued to

Wavin Building Products Ltd, Cobbs Wood, Ashford, Kent TN23 1EL.

*Details of Kitemark certification schemes can be obtained from Certification and Assessment Service Quality Assurance Services, British Standards Institution, P O Box 375, Milton Keynes MK14 6LO. Tel: Milton Keynes (0908) 315555; Telex: 82782.

** The letter after the manufacturer's catalogue number refers to the products covered by the following BSI Kitemark Licences:

- A — Nos 5452, 6000 and 7091
- B — Nos 5452 and 6000
- C — No 5452
- D — No 6000
- E — No 7133
- F — No 5314

Electronic Copy

Key to abbreviations:

P/E both ends plain or with one plain end and one special end

S/S one or more ring seal or push fit socket, but always with one plain or special end

D/S ring seal or push fit sockets at all ends

S/SW one or more ring seal sockets, but always with one solvent socket

SW/S one solvent socket and one plain or special end

D/SW solvent sockets at all ends

SW/½S half spigot or half socket ends



On behalf of the British Board of Agrément

Date of issue: 29th April 1987

Director

Recreated in QX 12.3.03 (sm)

British Board of Agrément

P O Box No 195, Bucknalls Lane
Garston, Watford, Herts WD25 9BA

Fax: 01923 665301

©1987

e-mail: mail@bba.star.co.uk
website: www.bbacerts.co.uk



For additional information about the Certificate, tel: 01923 665300.
For information about Agrément Certificate validity and scope, tel: Hotline 01923 665400, or check the BBA website.



Wavin Building Products Ltd

Certificate No 87/1835

**OSMADRAIN UNDERGROUND
DRAINAGE SYSTEM –INSTALLATION**

DETAIL SHEET 3
Second issue*

Product

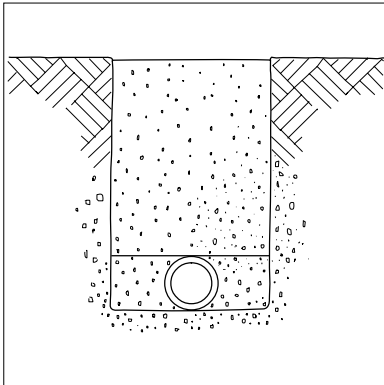

• THIS DETAIL SHEET RELATES TO THE INSTALLATION OF KITEMARKED OSMADRAIN 110 mm AND 160 mm DIAMETER PVC-U UNDERGROUND DRAIN PIPES AND FITTINGS TO BS EN 1401-1 : 1998 AND BS 4660 : 1989 (SEE DETAIL SHEET 2) AND PRODUCTS CERTIFICATED BY THE BBA AS DESCRIBED IN THIS CERTIFICATE.

Installation

1 General

Installation should be carried out in accordance with BS 5955 : Part 6 : 1980, BS EN 1610 : 1998, and BS EN 752 Parts 1 to 4.

2 Laying pipes

On trench bottom in granular material (see Figure 1)

Figure 1 Pipes laid on trench bottom

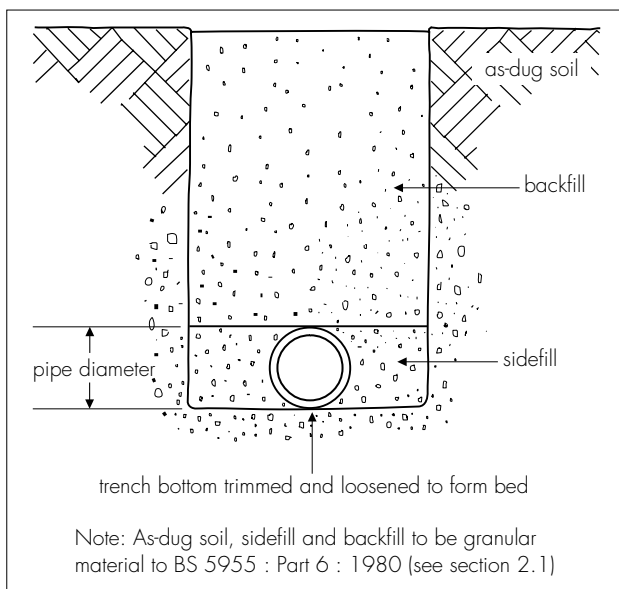

2.1 Where the as-dug material is suitable* for use as bedding, the bottom of the trench may be trimmed to form the pipe bed.

*Suitable material is defined as granular material in accordance with the recommendations of BS 5955 : Part 6 : 1980, Appendix A, having a nominal particle size not

exceeding 10 mm or 14 mm for 110 mm diameter and 160 mm diameter pipes, respectively.

2.2 Small depressions should be made to accommodate the pipe sockets or couplings. After the pipe has been laid these should be carefully filled to ensure that no voids remain under the socket.

2.3 When the formation is prepared, the pipes should be laid upon it true to line and level within the specified tolerances. Each pipe should be checked and any necessary adjustments to level made by raising or lowering the formation, ensuring that the pipes finally rest evenly on the adjusted formation throughout the length of the barrels. Adjustment should never be made by local packing.

2.4 Where the formation is low and does not provide continuous support, it should be brought up to the correct level by placing and compacting suitable material.

On granular beds (see Figures 2 and 3)

Figure 2 Pipes laid on 50 mm minimum pea gravel bedding

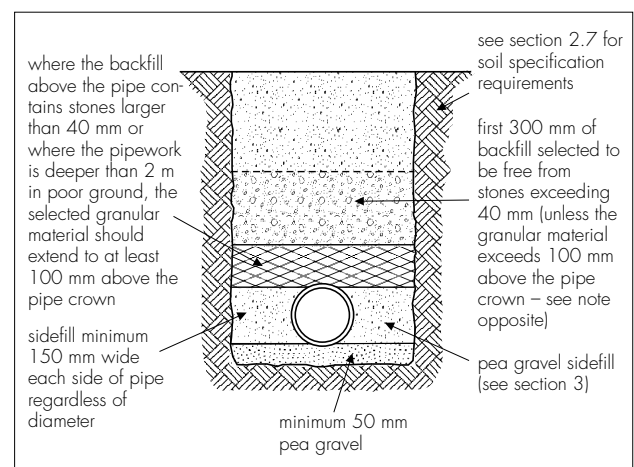
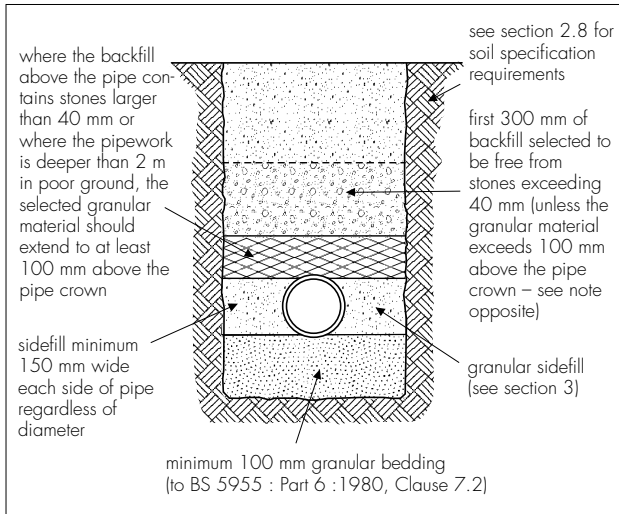

Figure 3 Pipes laid on 100 mm minimum granular bedding



2.5 When the as-dug material is not suitable as a bedding, a layer of suitable granular material (see section 2.1) must be spread evenly on the trimmed trench bottom before the pipes are installed. The trench should be excavated to allow for the thickness of granular bedding under the barrels.

2.6 The trench formation should be prepared, the bedding placed and the pipes laid in accordance with BS 5955 : Part 6 : 1980.

2.7 Where the as-dug material can be hand trimmed by shovel and is not puddled when walked upon, a 50 mm depth of bedding material may be used. In this case the material must be nominal 10 mm single-sized aggregate with no sharp edges, ie pea gravel (see Figure 2).

2.8 When the pipes are to be laid in rock, compacted sand and gravel requiring mechanical means of trimming, and in very soft or wet ground, the bedding should be a minimum of 100 mm in accordance with BS 5955 : Part 6 : 1980 (see Figure 3).

3 Sidefill

In all cases the sidefill must be of the same specification as the bedding material and extend to the level of the crown of the pipe and placed and compacted in accordance with BS 5955 : 1980 : Part 6.

4 Backfill

Backfill above the level of the crown of the pipe must be in accordance with BS 5955 : Part 6 : 1980 (see Figures 1, 2 and 3).

Bibliography

BS 4660 : 1989 — Specification for unplasticized polyvinyl chloride (PVC-U) pipes and plastics fittings of nominal sizes 110 and 160 for below ground gravity drainage and sewerage

BS 5955 *Plastics pipework (thermoplastics materials)*

Part 6 : 1980 *Code of practice for the installation of unplasticized PVC pipework for gravity drains and sewers*

BS EN 752 *Drains and sewer systems outside buildings*

BS EN 752-1 : 1996 *Generalities and definitions*

BS EN 752-2 : 1997 *Performance requirements*

BS EN 752-3 : 1997 *Planning*

BS EN 752-4 : 1998 *Hydraulic design and environmental considerations*

BS EN 1401 *Plastics piping systems for non-pressure underground drainage and sewerage — Unplasticized poly (vinyl chloride) (PVC-U)*

BS EN 1401-1 : 1998 *Specifications for pipes, fittings and the system*



On behalf of the British Board of Agrément

Date of Second issue: 24th December 1998

Director

*Original Detail Sheet issued 11th May 1987, this revised version issued to include reference to revised British Standards and associated text and the addition of the Bibliography.



Wavin Building Products Ltd

Certificate No 87/1835

DETAIL SHEET 7

OSMADRAIN UNIVERSAL GULLY

Product

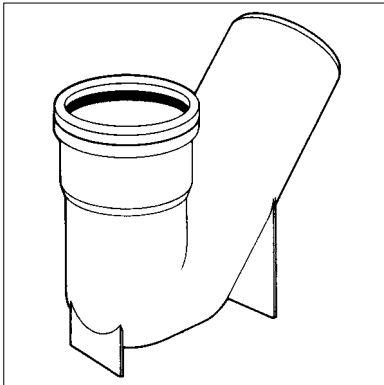

- THIS DETAIL SHEET REPLACES PART OF CERTIFICATE No 84/1371 AND RELATES TO THE OSMADRAIN UNIVERSAL GULLY.
- The gully is for use with 110 mm uPVC underground drain pipes and fittings to BS 4660 : 1973, to receive surface water from paved areas inaccessible to wheeled vehicles, surface water from roofs and/or waste water from ground floor domestic appliances.

This Detail Sheet must be read in conjunction with the Front Sheet and Detail Sheet 1 which give Conditions of Certification and the product's position regarding the Building Regulations respectively.

Technical Specification

1 Description

1.1 The universal gully is assembled from a range of components to allow various inlet and outlet arrangements to be made on site. The basic components are the gully trap, hopper and outlet bend (see Table 1 and Figures 1, 2 and 3). Dimensions are detailed in Wavin Building Products Ltd's *Product Catalogue*, reference BPC 1.

Table 1 Universal Gully and fittings

Manufacturer's catalogue No	Product
4D 161	Single socket short radius 87½° bend
4D 169	Single socket short radius 87½° access bend
4D 500	Single socket gully trap
4D 503	Solvent weld socket hopper (plain)
4D 504	solvent weld socket hopper (vertical inlet)
4D 507	Plain ended hopper (plain)
4D 508	Plain ended hopper (vertical inlet)
4D 525	Sealed access plate (spare)
4D 527	Plain ended sealed inspection hopper
4D 561	double socket short radius 87½° bend
4D 563	Double socket short radius 45° bend
4D 569	Double socket short radius 87½° access bend
4D 589	Single socket bossed pipe

1.2 The fittings are injection moulded in polypropylene or uPVC. The uPVC components comply with the quality and colour requirements of BS 4660 : 1973 *Specification for unplasticized PVC underground drain pipe and fittings*. Continuous quality control is exercised during manufacture and includes checks on stress relief, tensile strength and dimensional accuracy.

1.3 The 110 mm diameter ring seals are SBR (styrene butadiene rubber) to BS 2494 : 1986 *Specification for elastomeric joint rings for pipework and drainage*.

1.4 Some of the items used to construct the universal gully are kitemarked to BS 4660 : 1973 (see Detail Sheet 2).

2 Delivery and site handling

2.1 The components are delivered to site in plastic bags containing similar items. The packaging should be retained during storage to minimise the risk of loss or damage.

2.2 If long term storage in the open is envisaged then the fittings should be shaded from direct sunlight.

2.3 A label is fixed to each gully bearing the BBA identification mark incorporating the number of this Certificate.

Electronic Copy

Figure 1 Typical combinations for use with universal gully

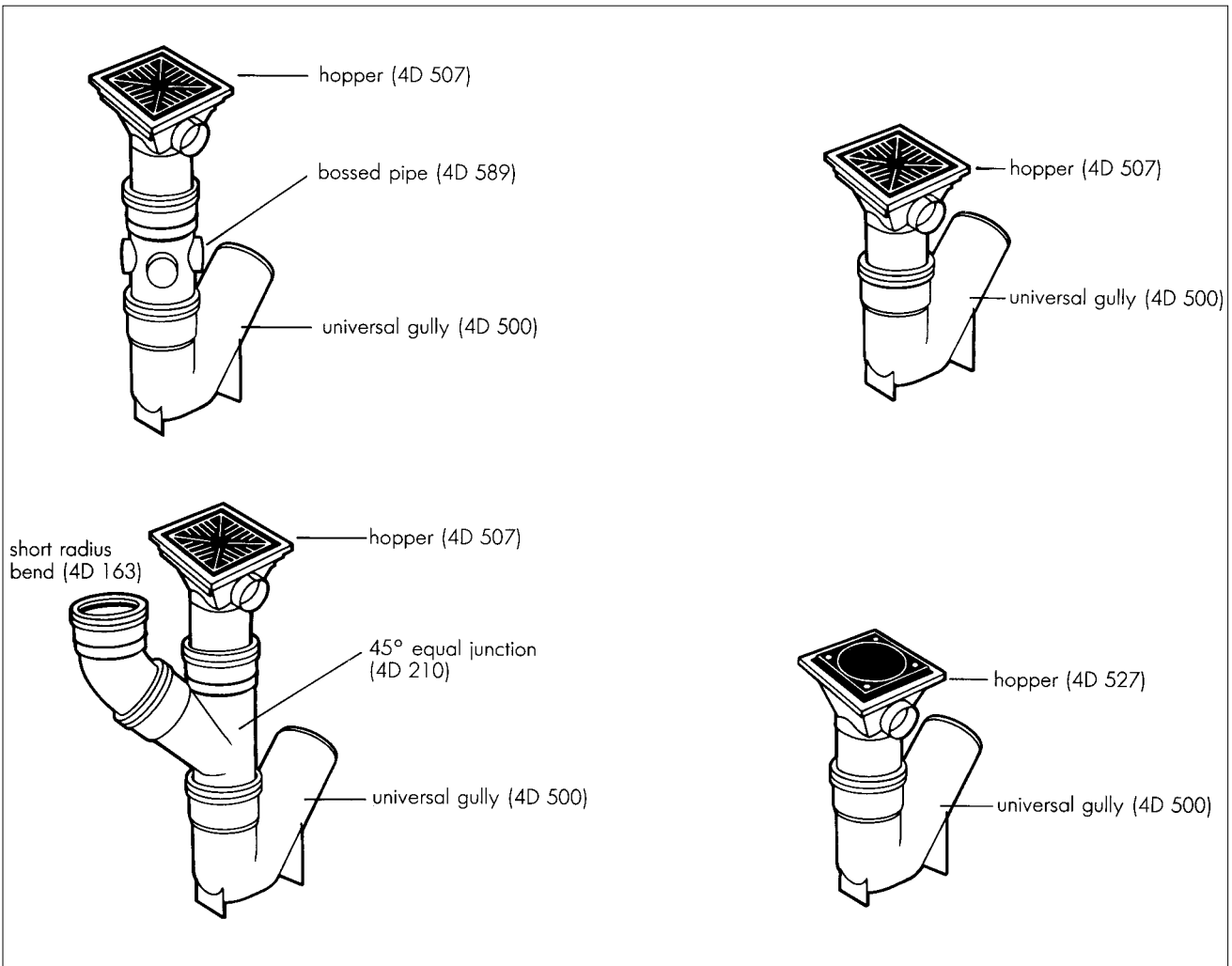

Figure 2 Alternative assemblies

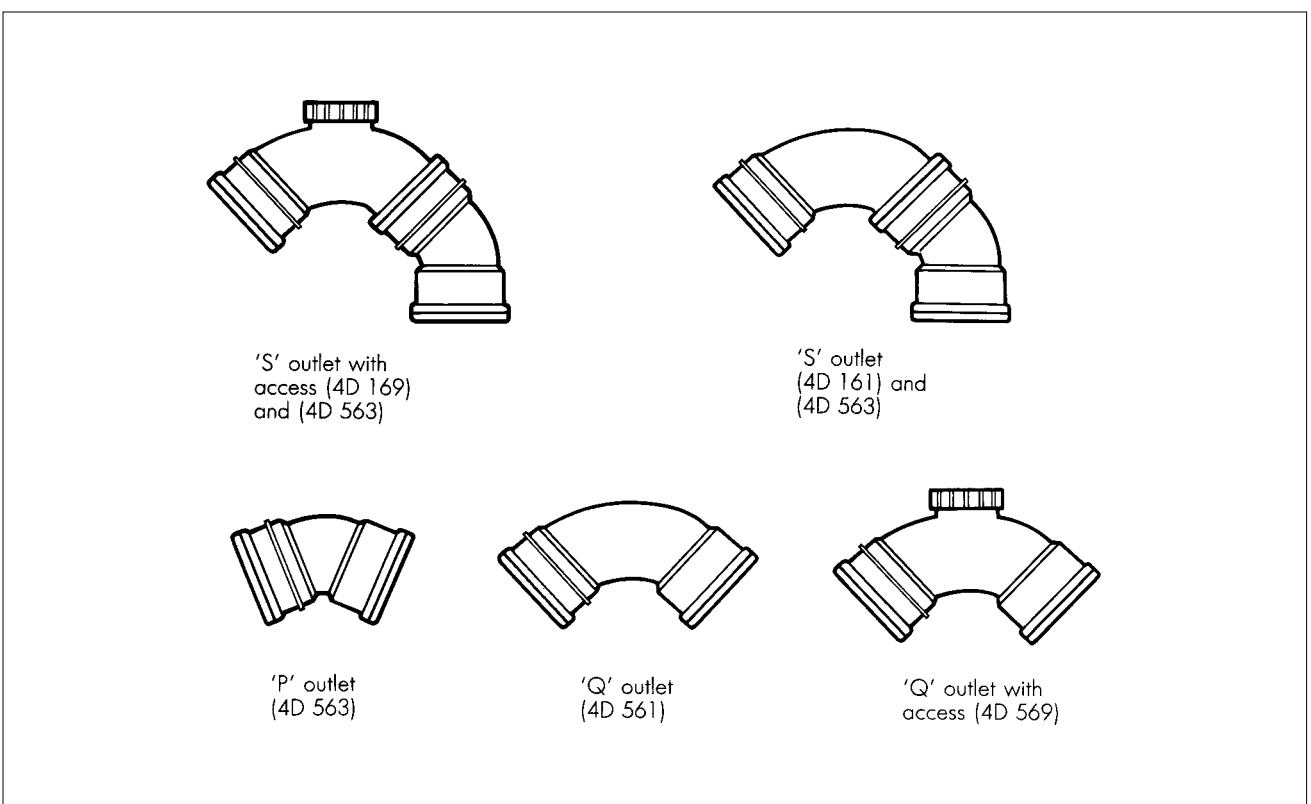
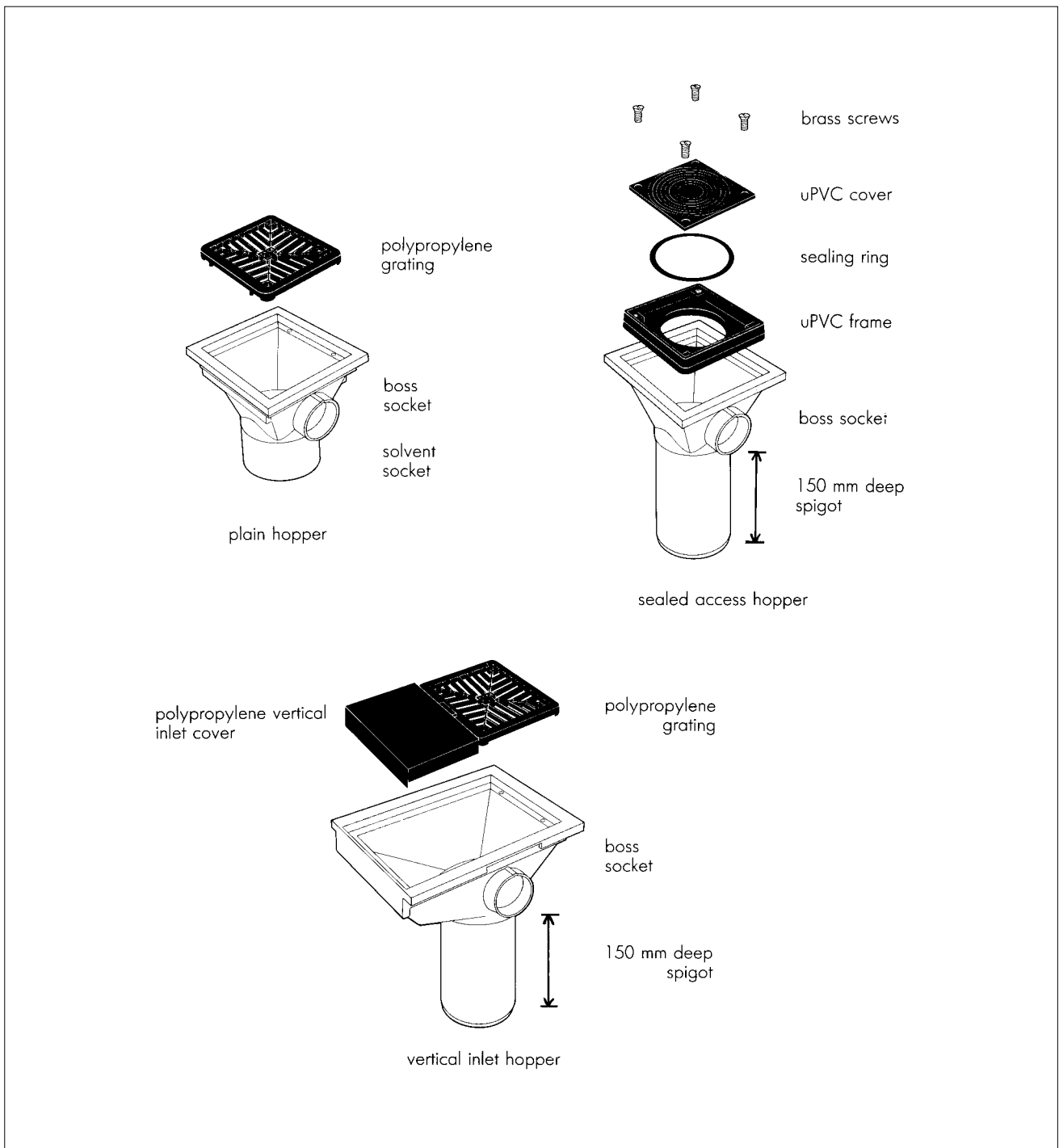



Figure 3 Detail of hoppers



Design Data

3 General

 The OsmaDrain Universal Gully is suitable for use in domestic drains designed in accordance with BS 8301 : 1985 *Code of practice for building drainage* for the conveyance, by combined or separate systems, of surface water as is permitted to be discharged into public sewers by the Public Health Act 1936, and surface water as is permitted and defined by the Sewerage (Scotland) Act 1968 and the Water and Sewerage Services (Northern Ireland) Order 1973.

4 Strength

 The universal gully has adequate strength to resist loads associated with installation and for subsequent use in situations inaccessible to wheeled vehicles.

5 Performance of joints

 5.1 Joints between the access systems, universal gully and drainage systems complying with BS 4660 : 1973 will remain watertight under conditions of deformation and pipeline deflection in excess of those expected to occur with normal good drainage practice.

5.2 The dimensions of sockets and sealing rings are such as to give satisfactory joints. The performance of the joints will not be affected by thermal movement when the system is correctly installed and limited to the conditions of use set out in this Detail Sheet.

6 Flow characteristics



6.1 The gully has adequate flow characteristics and will retain an effective water seal in conditions of induced or self-siphonage in excess of those associated with good drainage practice.

6.2 The sealed access hopper remains airtight under normal service conditions.

7 Resistance to chemicals



The universal gully will be unaffected by those types and quantities of chemicals associated with waste water and surface water.

8 Resistance to elevated temperatures



The gully has adequate resistance to temperatures which are likely to be found in waste and surface water.

9 Rodding



If access is required for rodding the drain from a position near the gully, an access bend (4D 569) and a cast iron cover and frame assembly 4D 324 must be used (see Figure 4a). The drain cannot be rodded through the universal gully.

10 Maintenance

Removal of the grating or sealed access plate will allow access to the gully trap for the removal of debris provided the recommended installation depths are not exceeded.

11 Durability

In the opinion of the BBA, when used in the context of this Detail Sheet, the materials from which the components are manufactured will not significantly deteriorate, and the system will have a life in excess of 50 years.

Figure 4 Typical installation details

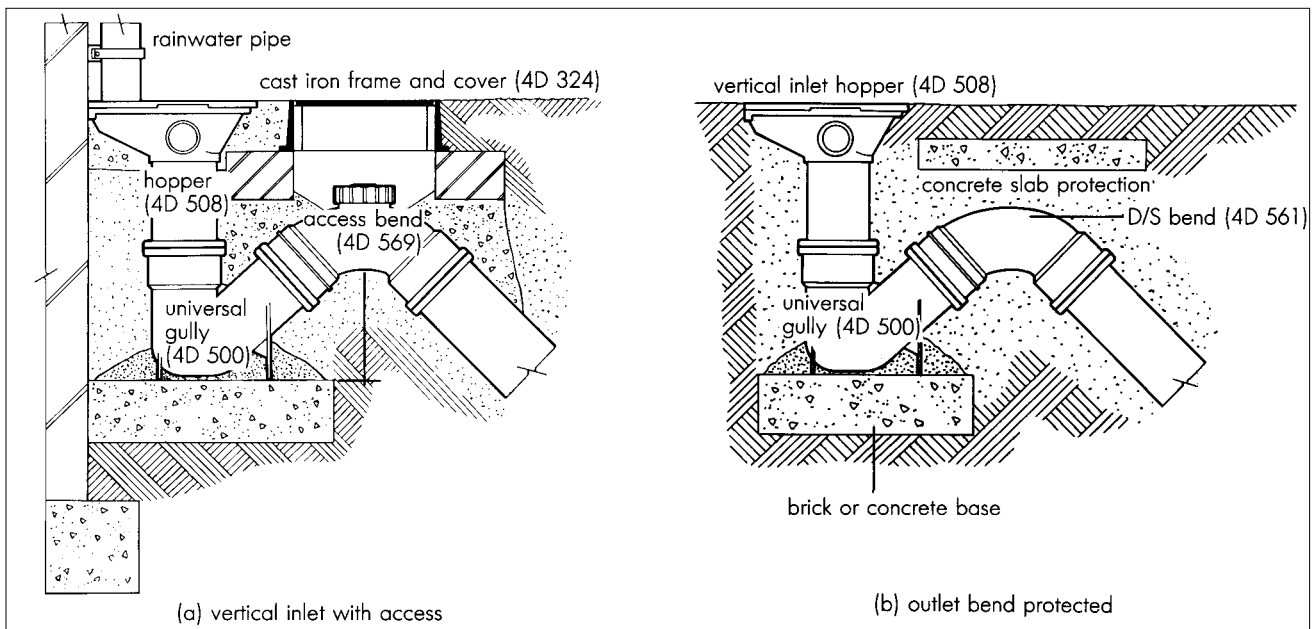

Installation

12 Procedure

12.1 Installation of the OsmoDrain Universal Gully must be in accordance with BS 5955 : Part 6 : 1980 *Plastics pipework (thermoplastics materials) — Code of practice for the installation of unplasticized PVC pipework for gravity drains and sewers*, BS 8301 : 1985 and Wavin Building Products Ltd's *OsmoDrain Installation Guide* publication BIG 1, October 1986.

12.2 Precautions must be taken during and after installation to protect the gully arrangements from damage due to site traffic.

12.3 The universal gully must be assembled above ground and then positioned on levelled bricks or a prepared concrete slab. The trap is then bedded and surrounded in concrete to give full support to the base. Connections are then made and the assembly backfilled as shown in Figures 3, 4 and 5 with suitable granular material.

Figure 5 Arrangements for particular use

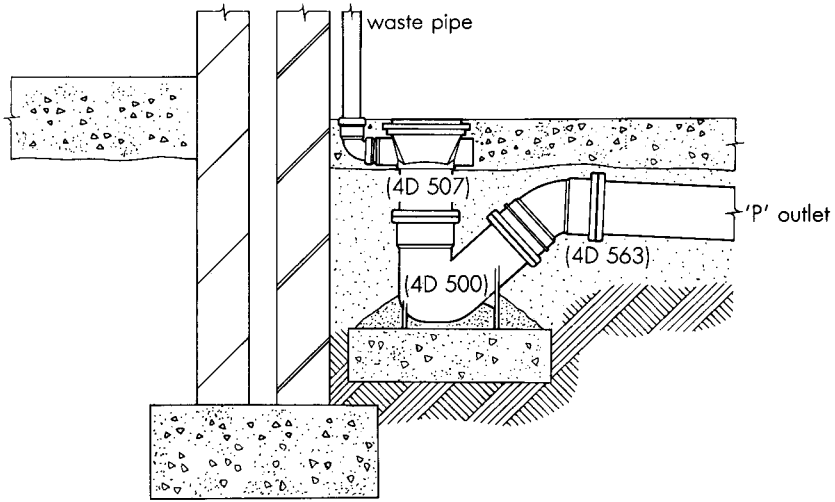

(a) horizontal inlet

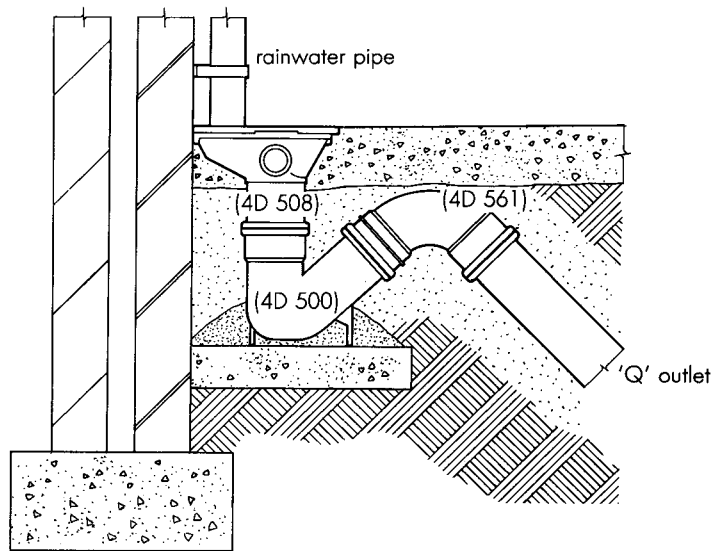

(b) vertical inlet

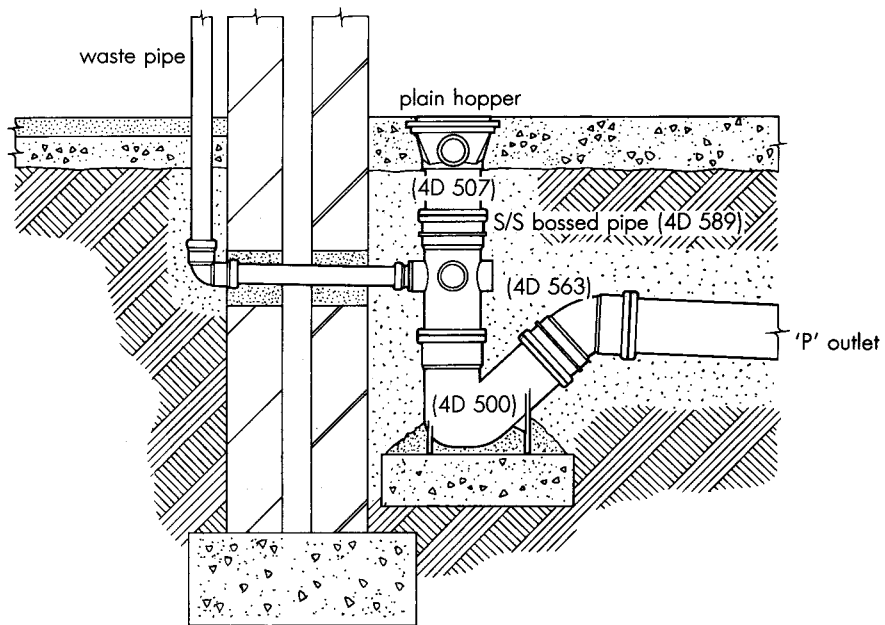

(c) deep horizontal inlet

12.4 The crown of the outlet bend from the gully must be below the level to which garden implements can penetrate when it is not protected by paving or concrete at ground level. When this is not practicable a concrete slab should be bedded above the bend (see Figure 4b).

12.5 The depth from ground level to the base of the trap should not exceed 600 mm to facilitate the removal of debris.

Technical Investigations

The following is a summary of the technical investigations carried out on the OsmaDrain Universal Gully.

13 Tests

Tests were carried out to determine:

dimensional accuracy
effect of thermal cycling to BS 4514 : 1969
Unplasticized PVC soil and ventilating pipe, fittings and accessories
Vicat softening point
impact resistance
practicability of installation
watertightness
airtightness.

14 Other investigations

14.1 An evaluation of existing data was made to assess the following:

resistance to chemicals
suitability of materials
durability
effect of syphonage on trap seal loss

14.2 The manufacturing process was examined including the methods adopted for quality control and details were obtained of the quality and composition of materials used.

14.3 An assessment was made of the flow characteristics.

14.4 A site visit was undertaken to assess the practicability of the installation instructions.



On behalf of the British Board of Agrément

Date of issue: 29th April 1987

A handwritten signature in black ink, appearing to read 'P. C. Newson'.

Director

Recreated in QX 12.3.03 (sm)



Wavin Building Products Ltd

Certificate No 87/1835

**OSMADRAIN 110 mm
ADJUSTABLE BENDS**

DETAIL SHEET 10
Second issue*

Product

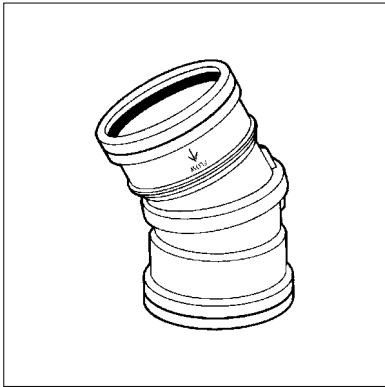

- THIS DETAIL SHEET RELATES TO THE OSMADRAIN 4D 173 AND 4D 573 110 mm DIAMETER POLYPROPYLENE ADJUSTABLE BENDS.
- The adjustable bends are for use with pipes and fittings complying with BS EN 1401-1 : 1998, BS 4660 : 1989 and BS 7158 : 1989, and with the components referred to in the accompanying Detail Sheets.

This Detail Sheet must be read in conjunction with the Front Sheet and Detail Sheet 1, which give the Conditions of Certification and the products' position regarding the Building Regulations, respectively.

Technical Specification

1 Description

1.1 The Osmadrain adjustable bend (see Figures 1 and 2) incorporates two mouldings pressed together to retain a sealing ring. The two components may be rotated to form any angle between 0° and 30°. The 4D 173 bend has a socket inlet and spigot outlet, the 4D 573 bend is a double socket fitting. Each socket incorporates a ring seal retained by a snap cap. The products have an arrow indicating the direction of flow.

Figure 1 Single socket adjustable bend

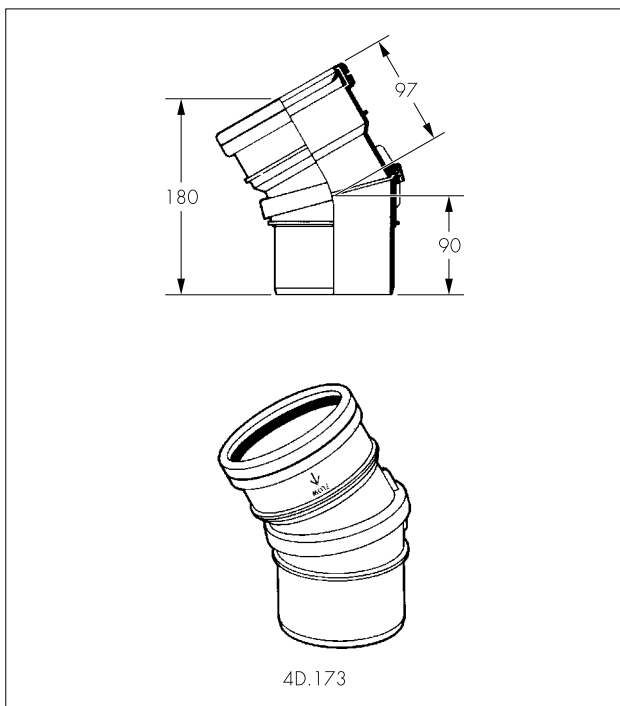
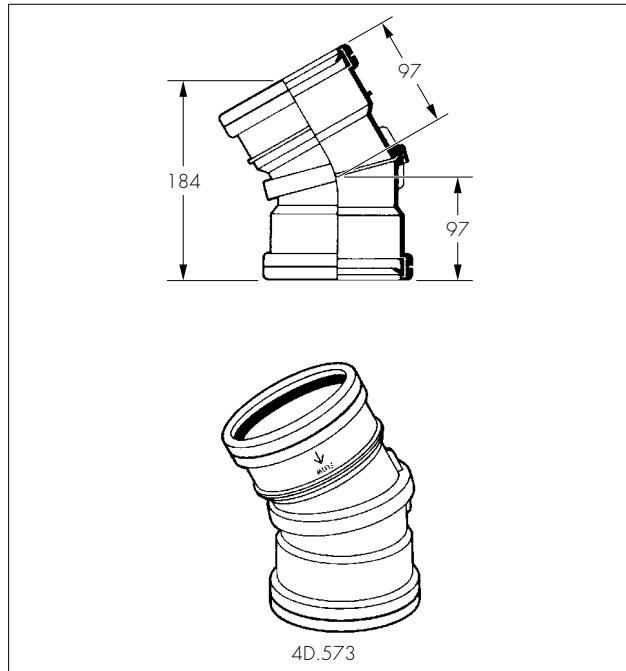

Figure 2 Double socket adjustable bend



- 1.2 The fitting body and snap cap are injection moulded in polypropylene.
- 1.3 Quality control checks, including visual dimensional checks, heat reversion and water pressure resistance tests, are carried out continuously during manufacture.
- 1.4 The sealing rings are Type WC BS EN 681-1 : 1996.
- 1.5 Each fitting is stamped with the manufacturer's name and product code number. A label bearing the BBA identification mark incorporating the number of this Certificate is attached to each fitting.

2 Delivery and site handling

The fittings are delivered to site in polythene bags. This packaging should be retained during storage to minimise the risk of damage to component parts.

Design Data

3 General



The 110 mm diameter adjustable bends have been assessed for use with pipes and fittings complying with BS EN 1401-1 : 1998, in domestic drains designed in accordance with BS EN 752 : 1996 : Parts 1 to 4, BS 4660 : 1989 and BS 7158 : 1989 for the conveyance, by combined or separate systems, of surface water and domestic sewage as is permitted to be discharged into public sewers by the Water Industry Act 1991 Chapter 56 and surface water and sewage as is permitted and defined by the Sewerage (Scotland) Act 1968 and the Water and Sewerage Services (Northern Ireland) Order 1973.

4 Strength



The adjustable bends have adequate strength to resist those loads associated with installation and with subsequent use in locations defined in this Detail Sheet.

5 Performance of joints



5.1 The performance of joints will not be adversely affected by thermal expansion or contraction when correctly made.

5.2 Joints with the pipeline remain watertight under conditions of pipeline movement in excess of those expected to occur in normal good drainage practice.

6 Flow characteristics



When used in underground drainage systems designed and installed in accordance with the recommendations given in this Detail Sheet, the adjustable bend will not adversely affect the flow characteristics of the system.

7 Resistance to chemicals



7.1 The products are suitable for use where pipes and fittings to BS EN 1401-1 : 1998 and BS 4660 : 1989 are normally used. They have adequate resistance to the type and quantity of chemicals likely to be found in domestic sewage.

7.2 Details of the chemical resistance of polypropylene are given in BS Code of Practice 312 : Part 1 : 1973.

8 Resistance to elevated temperatures



The products are for use where pipes and fittings to BS EN 1401-1 : 1998, BS 4660 : 1989 and BS 7158 : 1989 are normally used and have adequate resistance to the temperatures likely to be found in domestic sewage.

9 Practicability of installation



The products are installed easily under normal site conditions and are rotated easily to the required angle.

10 Rodding



Drains incorporating the product can be rodded easily using conventional flexible drain rods. Toothed root cutters, as used with some mechanical cleaning systems, could damage the fittings and these should not be used.

11 Durability



In the opinion of the BBA, when used in the context of this Detail Sheet, no significant deterioration of the product will take place and installations have a life in excess of 50 years.

Installation

12 General

12.1 Installation of the OsmaDrain 110 mm Adjustable Bend must be in accordance with the manufacturer's installation instructions, and Detail Sheet 3 of this Certificate.

12.2 Installations using the product are shown in Figures 3 to 7.

Electronic Copy

Figure 3 Installation of single socket adjustable bend

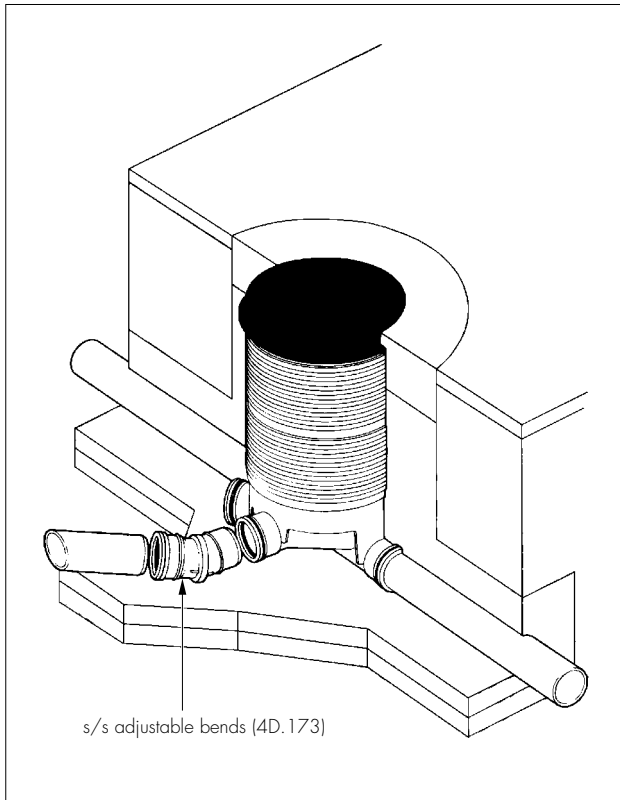
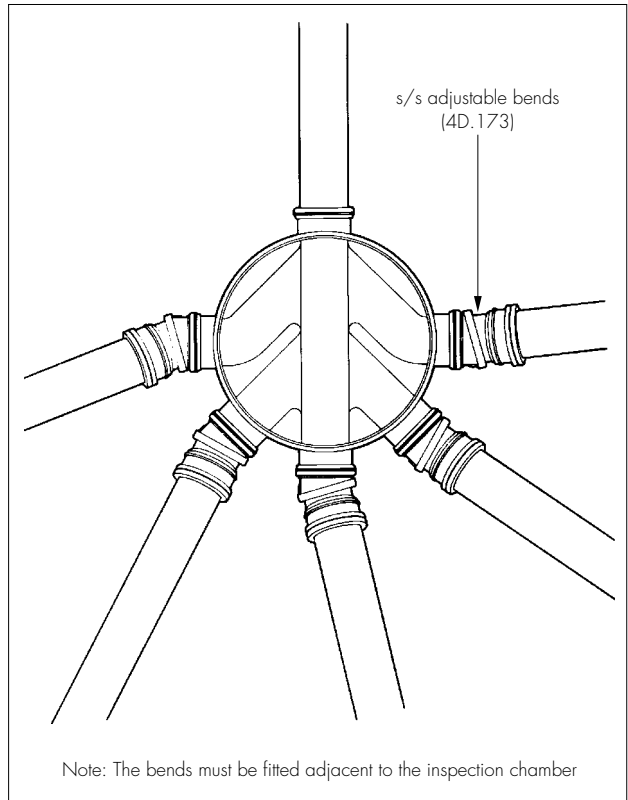

Figure 4 Permissible connections to inspection chamber



Electronic Copy

Figure 5 Double socket bend — change in gradient

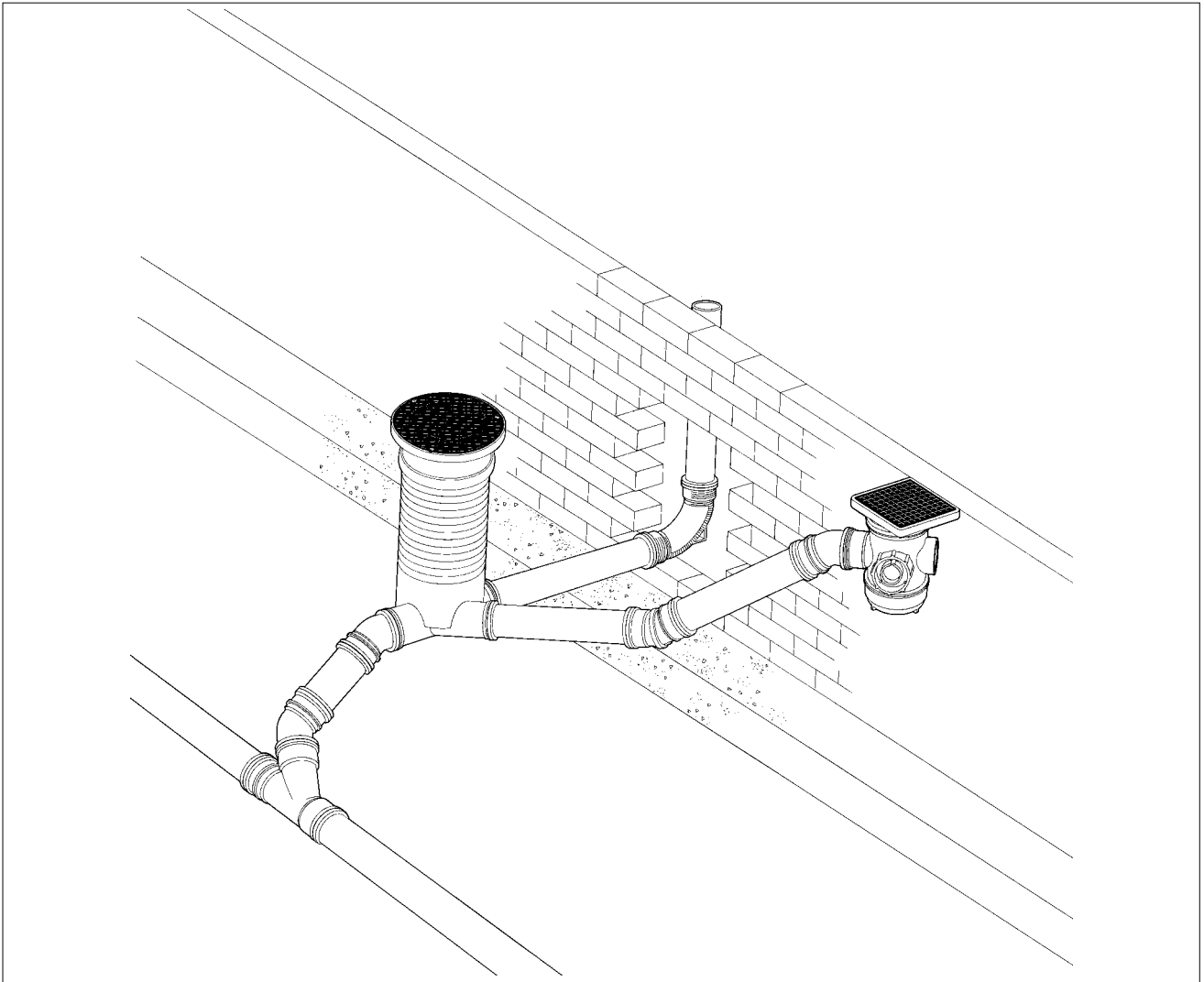

Figure 6 Double socket bend — manhole base

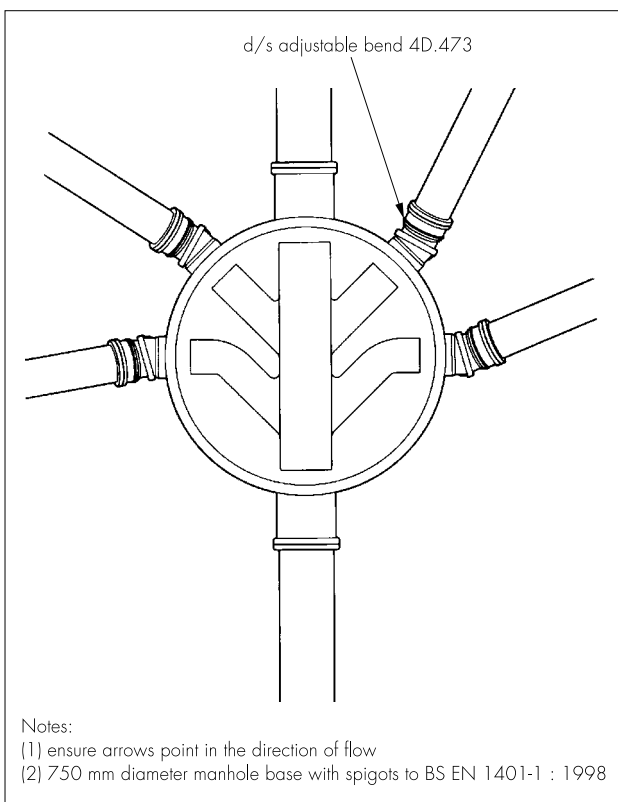
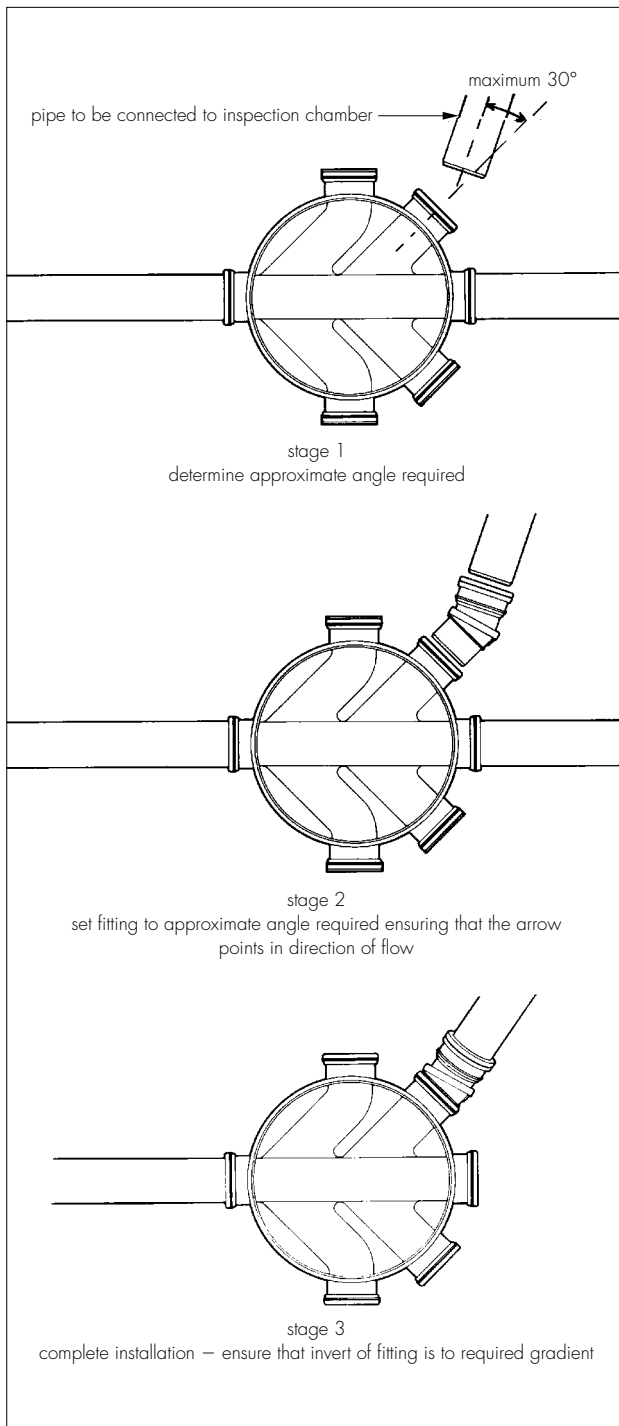

Figure 7 Installation procedure (typical)



13 Procedure

13.1 Joints are made as follows:

- The components to be joined are lined up. The flow direction indicator must point in the direction of flow.
- The fitting is rotated to the approximate angle required.
- Both socket and pipe or spigot must be cleaned.
- The ring seal must be correctly seated.

(e) The recommended lubricant is applied to the pipe or spigot.

(f) The pipe is inserted fully into the socket and approximately 10 mm is withdrawn to allow for expansion.

(g) It is important to ensure that the invert of the fitting follows the required gradient.

1.3.2 Drain and sewer systems utilising the bends should be installed in accordance with Detail Sheet 3 of this Certificate.

1.3.3 The systems must have adequate protection against damage from site construction traffic and from agricultural or similar operations.

Technical Investigations

The following is a summary of the technical investigations carried out on the OsmaDrain 110 mm Adjustable Bend.

14 Tests

Tests were carried out to determine:

- effect of combined hot and cold water discharges through the product whilst subjected to a loading of 35 kN (BS 4660 : 1973 Appendix K)
- dimensional accuracy
- watertightness of joints under conditions of pipe deformation and hydrostatic pressure of 0.35 bar
- watertightness of joints under conditions of vertical displacement and a hydrostatic pressure of 0.35 bar
- ease of jointing and rotating to angle required
- watertightness of central joint when subject to shear loads
- effect of rodding using polypropylene drain rods with various rodding heads.

15 Other investigations

15.1 An evaluation of existing data was made to assess:

- tensile strength
- compressive strength
- impact strength
- Vicat softening point
- resistance to chemicals
- flow characteristics
- durability.

15.2 The manufacturing process was examined, including the methods adopted for quality control, and details were obtained of the quality and composition of the materials used.

15.3 A visit was made to a site in progress to assess the practicability of installation.

Bibliography

BS 4660 : 1989 *Specification for unplasticized polyvinyl chloride (PVC-U) pipes and plastics fittings of nominal sizes 110 and 160 for below ground gravity drainage and sewerage*

BS 7158 : 1989 *Specification for plastics inspection chambers for drains*

BS EN 681 *Elastomeric seals : Material requirements for pipe joint seals used in water and drainage applications*

BS EN 681-1 : 1996 *Vulcanized rubber*

BS EN 752 *Drains and sewer systems outside buildings*

BS EN 752-1 : 1996 *Generalities and definitions*

BS EN 752-2 : 1997 *Performance requirements*

BS EN 752-3 : 1997 *Planning*

BS EN 752-4 : 1998 *Hydraulic design and environmental considerations*

BS EN 1401 *Plastics piping systems for non-pressure underground drainage and sewerage — Unplasticized poly (vinyl chloride) (PVC-U)*

BS EN 1401-1 : 1998 *Specifications for pipes, fittings and the system*

BS Code of Practice 312

Part 1 : 1973 *Code of Practice for Plastics pipework (thermoplastics material) — General principles and choice of material*



On behalf of the British Board of Agrément

Date of Second issue: 24th December 1998

Director

**Original Detail Sheet issued 17th November 1988, this revised version issued to include reference to revised British Standards and associated text and the addition of the Bibliography.*



Wavin Building Products Ltd

Certificate No 87/1835

DETAIL SHEET 12

Second issue*

OSMADRAIN YARD GULLY

Product

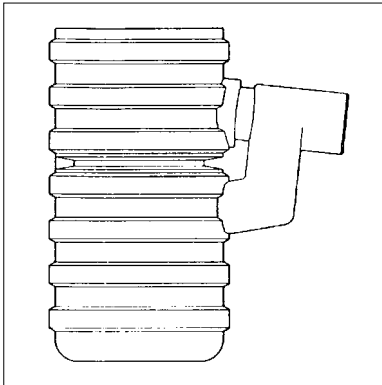

- THIS DETAIL SHEET RELATES TO THE OSMADRAIN YARD GULLY.
- The product is for use as a trapped gully for connection to 110 mm PVC-U pipes and fittings to BS EN 1401-1 : 1998 and BS 4660 : 1989.
- The gully is for use in situations where Class B125 covers to BS EN 124 : 1994 would be suitable.
- This Detail Sheet does not cover the use of the gully for domestic sewerage, combined sewerage systems or untreated trade effluents.

This Detail Sheet must be read in conjunction with the Front Sheet and Detail Sheet 1, which give the Conditions of Certification and the product's position regarding the Building Regulations, respectively.

Technical Specification

1 Description

1.1 The Osmadrain Yard Gully comprises a blow-moulded, high density polyethylene (HDPE) gully with an internal diameter of 305 mm and depth of 600 mm (see Figure 1).

Figure 1 Gully details

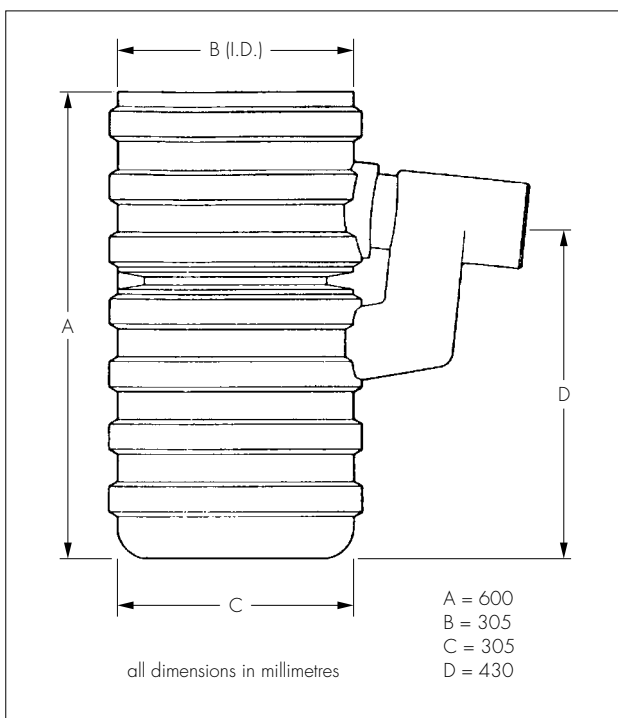

1.2 The trapped gully incorporates an integral trap, outlet spigot and an EPDM rubber plug and retaining strap to BS EN 681-1 : 1996, Type W6.

If the access plug is not used, the gully is considered to be untrapped.

1.3 A perforated galvanized mild steel catchment bucket is available for use with the gully (see Figure 2).

Figure 2 Catchment bucket

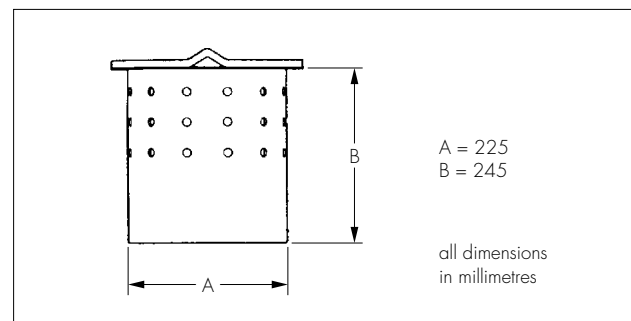

1.4 A cast iron grating and frame, kitemarked for use as a Class B125 cover to BS EN 124 : 1994, are available for use with the gully (grating dimensions 303 mm by 325 mm).

1.5 Joints to PVC-U pipe to BS EN 1401-1 : 1998 can be made directly from the outlet using standard BS EN 1401-1 and BS 4660 : 1989 connectors.

1.6 Quality control includes visual examinations on each moulding and checks on dimensions and weight.

2 Delivery to site, handling and storage

The Osmadrain Yard Gully is delivered to site unprotected and is identified by the manufacturer's product code and a label bearing the BBA identification mark incorporating the number of this Certificate.

Design Data

3 General

3.1 The gully is for use with pipes and fittings complying with BS EN 1401-1 : 1998 and BS 4660 : 1989 in surface water drainage systems designed in accordance with BS 6367 : 1983 and BS EN 752 : 1996, Parts 1 to 4, for the conveyance of surface water.

3.2 This Detail Sheet does not cover the use of the gully for domestic sewage, combined sewerage systems or untreated trade effluents.

4 Flow characteristics

The gully has a nominal holding capacity of 26 litres.

5 Strength

The product has adequate strength to resist loads associated with installation and with subsequent use in the situations defined in the *Product* part of this Detail Sheet.

6 Watertightness

The connection between the gully and pipes and fittings to BS EN 1401-1 : 1998 and BS 4660 : 1989 is watertight.

7 Rodding and maintenance

The drain from the gully may be rodded, using flexible drain rods, by removing the access plug. To maintain the effectiveness of the trap the plug must be replaced after rodding.

8 Practicability of installation

The gully is installed easily under normal site conditions.

9 Resistance to chemicals

The gully will be unaffected by those types and quantities of chemicals likely to be found in surface water.

10 Durability

The gully will have a life equivalent to that of PVC-U drainage systems.

Installation

11 Procedure

11.1 The gully should be installed in a suitably sized excavation allowing an additional 150 mm under and around the gully (see Figure 3).

11.2 A bed of 150 mm granular material is laid.

11.3 The gully is set level and in line with the branched drain.

11.4 The gully is connected to the branch drain and surrounded by granular material to a maximum depth of 350 mm.

11.5 The rest of the excavation is filled with concrete and the grating and frame bedded in a suitable concrete mix.

Figure 3 Typical installation details

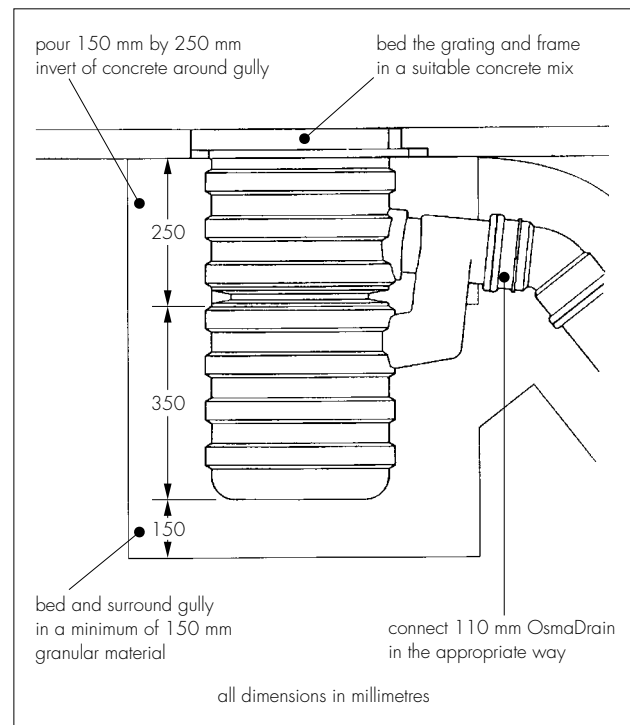

Technical Investigations

The following is a summary of the technical investigations carried out on the OsmaDrain Yard Gully.

12 Tests

Tests were carried out to determine:

dimensional accuracy

density of HDPE to ISO 1183 : 1987, Method A

Vicat softening temperature to ISO 306 : 1987, Method A

ash content to ISO 1270 : 1975 : Method A

tensile strength and elongation to ISO R 527 : 1966

melt flow rate of BS 2782 : Part 7 :

Method 720A : 1979

watertightness of gully and connection

capacity

resistance to external hydrostatic pressure

resistance to wheel loads.

13 Other investigations

13.1 An evaluation of existing data was made to assess resistance to chemicals and durability.

Electronic Copy

13.2 The manufacturing process was examined, including the methods adopted for quality control, and details were obtained of the quality and composition of the materials used.

Bibliography

BS 2782 *Methods of testing plastics*

Part 7 *Rheological properties*

Method 720A : 1979 *Determination of melt flow rate of thermoplastics*

BS 4660 : 1989 *Specification for unplasticized polyvinyl chloride (PVC-U) pipes and plastics fittings of nominal sizes 110 and 160 for below ground gravity drainage and sewerage*

BS 6367 : 1983 *Code of practice for drainage of roofs and paved areas*

BS EN 124 : 1994 *Gully tops and manhole tops for vehicular and pedestrian areas — Design requirements, type testing, marking, quality control*

BS EN 752 *Drains and sewer systems outside buildings*

BS EN 752-1 : 1996 *Generalities and definitions*

BS EN 752-2 : 1997 *Performance requirements*

BS EN 752-3 : 1997 *Planning*

BS EN 752-4 *Hydraulic design and environmental considerations*

ISO 306 : 1987 *Plastics — Thermoplastics materials — Determination of Vicat softening point : Method A*

BS EN 1401 *Plastics piping systems for non-pressure underground drainage and sewerage — Unplasticized poly (vinyl chloride) (PVC-U)*

BS EN 1401-1 : 1998 *Specifications for pipes, fittings and the system*

ISO R 527 : 1966 *Plastics. Determination of tensile properties*

ISO 1183 : 1987 *Plastics. Methods for determining the density and relative density of non-cellular plastics : Method A*

ISO 1270 : 1975 *Plastics. PVC Resins : Determination of ash and sulphated ash : Method A*



On behalf of the British Board of Agrément

Date of Second issue: 24th December 1998

A handwritten signature in black ink, appearing to read 'P. C. Hewson'.

Director

*Original Detail Sheet issued 7th March 1995. This revised version issued to include reference to revised British Standards and associated text and the addition of the Bibliography.

Electronic Copy

British Board of Agrément
P O Box No 195, Bucknalls Lane
Garston, Watford, Herts WD2 7NG
Fax: 01923 665301

©1999

e-mail: mail@bba.star.co.uk
<http://www.bbacerts.co.uk>



For technical or additional
information, tel: 01923 665300.
For information about Agrément
Certificate validity and scope, tel:
Hotline: 01923 665400