

## Forticrete Limited

Hillhead Quarry  
Harper Mill  
Buxton  
Derbyshire SK17 9PS  
Tel: 01298 23333 Fax: 01298 23000  
e-mail: info@forticrete.com  
website: www.forticrete.com

**Roads and Bridges  
Agrément Certificate  
No 04/R137**

**BBA** BRITISH BOARD OF AGREMENT  
TECHNICAL APPROVALS FOR CONSTRUCTION

Designated by Government  
to issue  
European Technical  
Approvals

## FORTICRETE KEYSTONE SYSTEMS FOR REINFORCED SOIL RETAINING WALLS AND BRIDGE ABUTMENTS

Système de renforcement des sols  
Bodenverfestigung

## Product

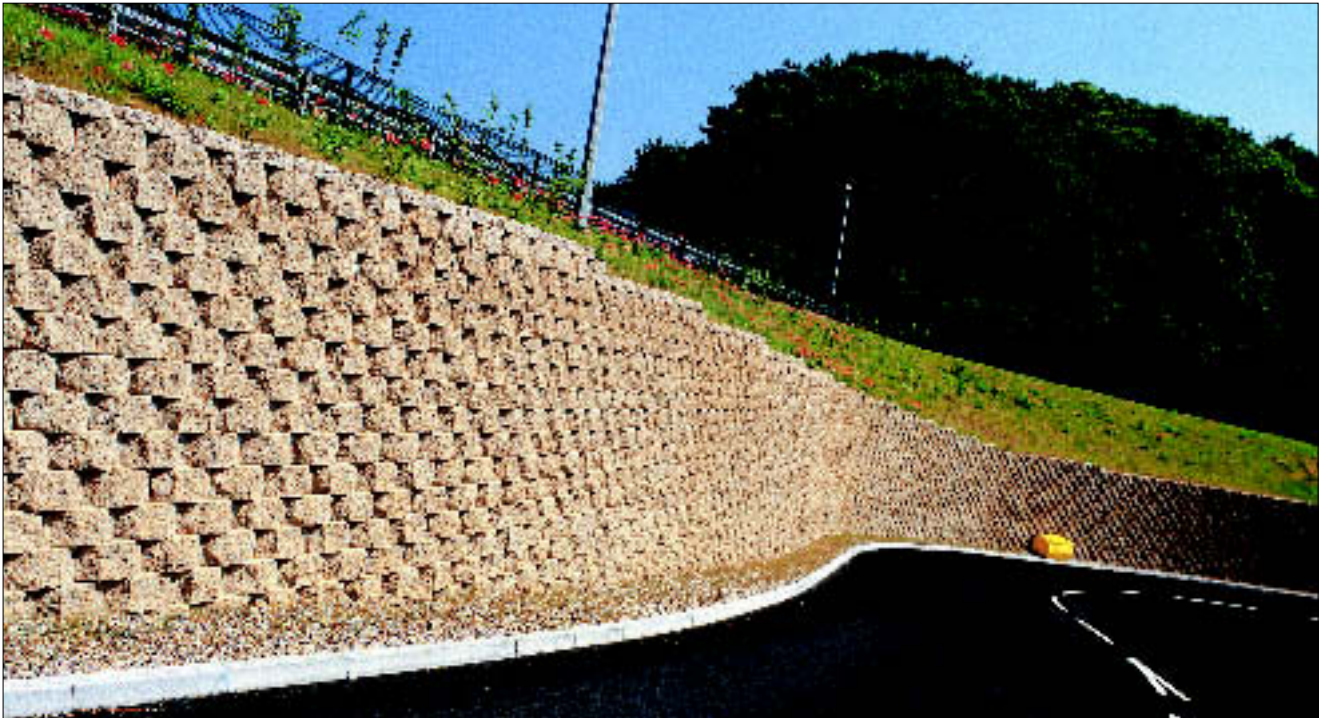

- THIS CERTIFICATE REPLACES CERTIFICATE No 98/R103 AND RELATES TO THE FORTICRETE KEYSTONE SYSTEMS FOR REINFORCED SOIL RETAINING WALLS AND BRIDGE ABUTMENTS, REFERRED TO IN THE ACCOMPANYING DETAIL SHEETS.

- The systems are based on the use of proprietary dry-jointed concrete block facing units in combination with proprietary reinforcement identified in the accompanying Detail Sheets.

- The design and construction of the reinforced soil structure must be in accordance with the requirements of the Highways Agency (HA); acting on behalf of the Department for Transport, the Scottish Executive Development Department, the Welsh Assembly Government, and the Department for Regional Development, Northern Ireland; and the conditions set out in the Design Data and Installation parts of this Certificate.

This Front Sheet must be read in conjunction with the accompanying Detail Sheets, which provides information specific to the system.

## Highways Agency Requirements — Detail Sheet 1

### 1 Requirements

1.1 All proposals for adopting the system shall comply with current HA design and certification procedures and relevant design data shall be submitted in accordance with the requirements of section 3 of the accompanying Detail Sheets.

1.2 The design, materials specification and construction methods adopted must be in accordance with the HA Technical Standard BD 70/03 (DMRB 2.1.5), and Manual of Contract Documents for Highway Works (MCHW) Volume 1, May 2001.

## Regulations

### 2 Construction (Design and Management) Regulations 1994 (as amended)

#### Construction (Design and Management) Regulations (Northern Ireland) 1995 (as amended)

Information in this Certificate may assist the client, planning supervisor, designer and contractors to address their obligations under these Regulations.

See sections:

2 Delivery to site, handling and storage (2.1) and  
8 Installation (8.1) of Detail Sheets 2 and 3.

Readers are advised to check the validity of this Certificate by either referring to the BBA's website ([www.bbacerts.co.uk](http://www.bbacerts.co.uk)) or contacting the BBA direct (Telephone Hotline 01923 665400).

## Additional Information

The quality management systems of Forticrete Ltd have been assessed and registered as meeting the requirements of BS EN ISO 9002 : 1994 by British Standards Institution Quality Assurance (Certificate Number FM 00562).

## Bibliography

BS EN ISO 9002 : 1994 *Quality systems — Model for quality assurance in production, installation and servicing*

BD 70/03 *Strengthened Reinforced Soils and other Fills for Retaining Walls and Bridge Abutments*

Manual of Contract Documents for Highway Works, Volume 1 : *Specification for Highway Works* : May 2001 edition

## Conditions of Certification

### 3 Conditions

3.1 This Certificate:

- (a) relates only to the product that is described, installed, used and maintained as set out in this Certificate;
- (b) is granted only to the company, firm or person identified on the front cover — no other company, firm or person may hold or claim any entitlement to this Certificate;
- (c) is valid only within the UK;
- (d) has to be read, considered and used as a whole document — it may be misleading and will be incomplete to be selective;
- (e) is copyright of the BBA;
- (f) is subject to English law.

3.2 References in this Certificate to any Act of Parliament, Regulation made thereunder, Directive or Regulation of the European Union, Statutory Instrument, Code of Practice, British Standard, manufacturers' instructions or similar publication, are references to such publication in the form in which it was current at the date of this Certificate.

3.3 This Certificate will remain valid for an unlimited period provided that the product and the manufacture and/or fabrication including all related and relevant processes thereof:

- (a) are maintained at or above the levels which have been assessed and found to be satisfactory by the BBA;
- (b) continue to be checked as and when deemed appropriate by the BBA under arrangements that it will determine;
- (c) are reviewed by the BBA as and when it considers appropriate; and
- (d) remain in accordance with the requirements of the Highways Agency.

3.4 In granting this Certificate, the BBA is not responsible for:

- (a) the presence or absence of any patent or similar rights subsisting in the product or any other product;
- (b) the right of the Certificate holder to market, supply, install or maintain the product; and
- (c) the nature or standard of individual installations of the product or any maintenance thereto, including methods and workmanship.

3.5 Any recommendations relating to the use or installation of this product which are contained or referred to in this Certificate are the minimum standards required to be met when the product is used. They do not purport in any way to restate the requirements of the Health & Safety at Work etc Act 1974, or of any other statutory, common law or other duty which may exist at the date of this Certificate or in the future; nor is conformity with such recommendations to be taken as satisfying the requirements of the 1974 Act or of any present or future statutory, common law or other duty of care. In granting this Certificate, the BBA does not accept responsibility to any person or body for any loss or damage, including personal injury, arising as a direct or indirect result of the installation and use of this product.



In the opinion of the British Board of Agrément, the Forticrete Keystone Systems for Reinforced Soil Retaining Walls and Bridge Abutments are fit for their intended use provided they are installed, used and maintained as set out in this Certificate. Certificate No 04/R137 is accordingly awarded to Forticrete Limited.

On behalf of the British Board of Agrément

A handwritten signature in black ink, appearing to read 'P. C. Hewson', is written over a light grey background.

Date of issue: 16th January 2004

Chief Executive

British Board of Agrément

P O Box No 195, Bucknalls Lane  
Garston, Watford, Herts WD25 9BA  
Fax: 01923 665301

©2004

e-mail: mail@bba.star.co.uk  
website: www.bbacerts.co.uk



For technical or additional information, contact the Certificate holder (see front page).  
For information about the Agrément Certificate, including validity and scope, tel: Hotline 01923 665400, or check the BBA website.



Forticrete Ltd

**FORTICRETE KEYSTONE REINFORCED  
SOIL RETAINING WALL AND BRIDGE  
ABUTMENT SYSTEM**

**Roads and Bridges  
Certificate No 04/R137  
DETAIL SHEET 2**

## Product



- THIS DETAIL SHEET RELATES TO THE FORTICRETE KEYSTONE REINFORCED SOIL RETAINING WALL AND BRIDGE ABUTMENT SYSTEM, COMPRISING THE STANDARD OR COMPAC CONCRETE BLOCK FACING UNITS IN COMBINATION WITH TENSAR SR55, SR80 AND SR110 GEOGRIDS.
- The blocks and geogrids are connected by a combination of pultruded glass-reinforced polyester (GRP) dowels and frictional-fill material.
- The Forticrete Keystone system is marketed in the United Kingdom by Forticrete Ltd.

This Detail Sheet must be read in conjunction with the Front Sheet, which gives HA requirements and the Conditions of Certification.

## Technical Specification

### 1 Description

1.1 The system comprises:

- Forticrete Keystone concrete block facing units
- pultruded GRP dowels
- selected granular fill to all voids in, around and behind the facing units
- Tensar SR55, SR80, SR110 geogrids.

#### Forticrete Keystone concrete block facing units

1.2 The concrete block facing units covered by this Certificate are the Standard ('Rockface' and 'Classic') and Compac ('Rockface' and 'Classic') types (see Figure 1). All units are manufactured to the same concrete mix specification. A non-structural capping unit, for the top of the wall, is also available for both Standard and Compac units.

1.3 All pigments used for the coloration of the concrete blocks comply with BS EN 12878 : 1999.

1.4 Facing units are manufactured in block machines, where mechanical vibratory compaction

# Electronic Copy

and sizing is used with semi-dry concrete to achieve the specified minimum compressive strength, water absorption and block shape:

- minimum concrete strength —  $30 \text{ Nmm}^{-2}$  at 28 days
- water absorption — a maximum of 6% when tested in accordance with the method of BS 7263-1 : 2001, Annex C
- density range — average value to be a minimum of  $1925 \text{ kgm}^{-3}$  when tested in accordance with the method of BS 6073-2 : 1981, Appendix C.

1.5 The concrete mix specification comprises a minimum cement content of  $365 \text{ kgm}^{-3}$  and a maximum water/cement ratio of 0.5.

1.6 The blocks are cured for a minimum 24-hour period in a temperature- and humidity-controlled internal environment.

1.7 Factory production control is undertaken throughout all stages of manufacture. Checks include:

- formalised daily patrol checks
- formalised recording of use of correct concrete mix specification
- visual checks on appearance of demoulded units and hourly measurements of block heights
- compressive strength and measured density recording at seven days on three samples taken from each block type produced per day
- formalised acceptance of product after completion of all quality control checks (minimum period before products released for use is seven days).

## Pultruded GRP dowels

1.8 The GRP dowels are manufactured by a pultrusion process and supplied by Pultron Composites Limited (to approved specifications) to achieve both the required durability and long-term mechanical properties.

## Selected granular fill to all voids in, around and behind the facing units

1.9 The granular fill material to all voids must be a crushed, coarse aggregate graded 4 mm to 20 mm in accordance with BS EN 12620 : 2002. Pea gravel or other rounded aggregates must not be used.

## Tensar SR55, SR80, SR110 geogrids

1.10 The technical specification must comply with BBA Certificate No 99/R108.

## Fill

1.11 The fill material used in the structure should comply with the requirements of one of the class 6I, 6J, 7B, 7C or 7D of the HA specification (MCHW1) and with BD 70/03.

Figure 1 Types of block

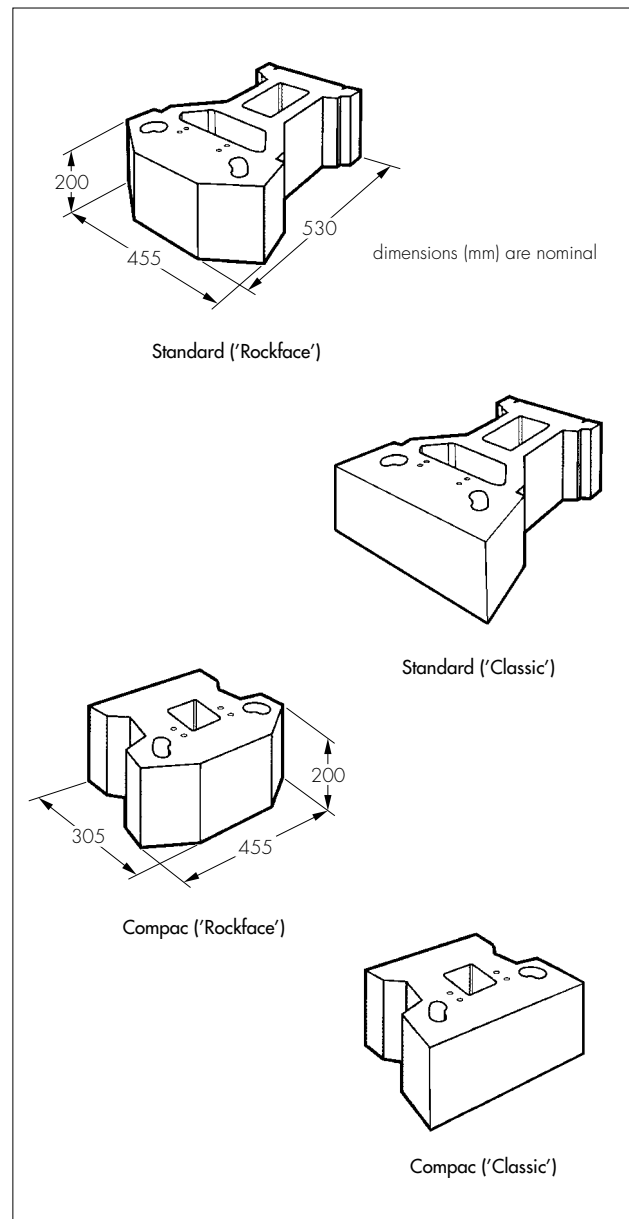

## 2 Delivery to site, handling and storage

### Facing units

2.1 The facing units are delivered to site on shrink-wrapped pallets. They carry a manufacturer's label or marking identifying the product type and batch code. Pallets should not be stacked more than two high.

2.2 To prevent damage, care should be taken in transit and handling. During prolonged periods of storage on site the units should remain covered on pallets.

### Pultruded GRP dowels

2.3 The GRP dowels are delivered to site in boxes. Care should be taken in storage, transit and handling on site.

### Tensar SR55, SR80, SR110 geogrids

2.4 The geogrids should be handled and stored generally in accordance with HA requirements and BBA Certificate No 99/R108.

## Design Data

### 3 General

3.1 The Forticrete Keystone Reinforced Soil Retaining Wall and Bridge Abutment System is satisfactory for use in providing reinforced soil retaining walls. Walls up to a maximum height of six metres are covered by this Certificate. Structural stability is achieved through the frictional interaction and interlock of the soil particles and the geogrid and by the mechanical connection of the geogrid to the facing units via the GRP dowels and the granular void fill (see Figures 2 and 3).

Figure 2 Geogrid fixed to block

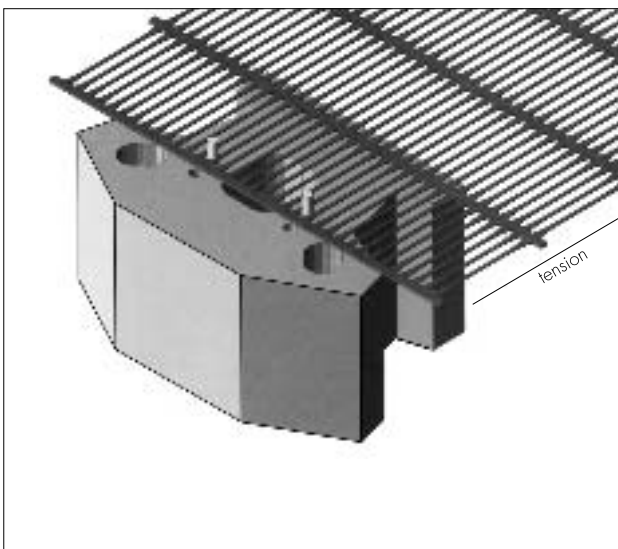
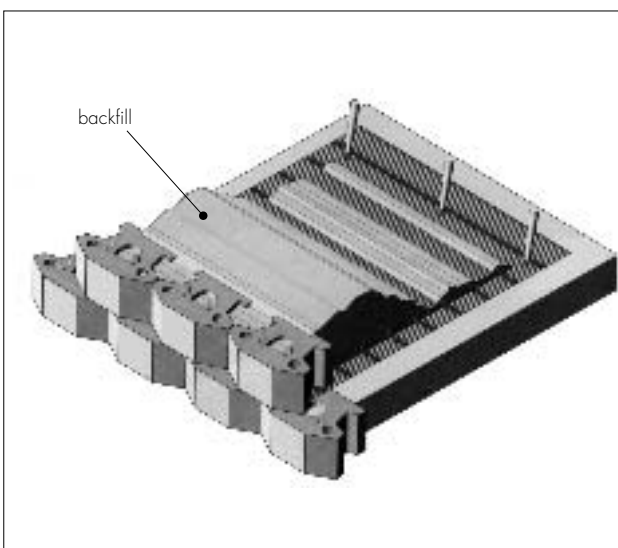

Figure 3 Next layer of blocks installed



3.2 The BBA has not assessed this system for supporting parapet loading caused by vehicle collision at the top of the facing units. When applicable this aspect of a design would require separate consideration and approval by the HA.

3.3 The system should be protected against horizontal impact loads caused by possible vehicle collision with the lower facing units of the wall.

3.4 Design of the reinforced soil wall must be in accordance with HA requirements and carried out by a suitably qualified engineer.

3.5 Prior to the commencement of the work, the designer shall submit to the HA nominee via the main contractor, relevant design and check certificates in accordance with current HA requirements and, as required, details:

- working drawings
- calculations
- source of fill material
- acceptable moisture content of fill material at time of placement
- method of tightening geogrids prior to fill placing
- sequence of placing fill material
- estimated movements of facing units during filling and compaction operations
- tolerance on the position of finished line of the wall.

### 4 Practicability of installation

4.1 The system is installed easily, provided all requirements of BBA Certificate No 99/R108 and section 8 of this Detail Sheet are complied with.

4.2 It is important that the first and each subsequent course of concrete block units is laid accurately to the correct line and level to avoid compounding errors in alignment as the wall is built.

4.3 Where accurate cutting of facing units is required on site, this should be carried out by disc-cutting techniques.

4.4 To avoid problems with the level of the facing units, the geogrid should not be lapped when attached to the GRP dowels. Adjacent strips of geogrids should be positioned to abut.

### 5 Design considerations

#### General

5.1 Walls utilising the Forticrete Keystone reinforced soil system must be designed in accordance with BD 70/03.

5.2 Adequate consideration must be given to the provision of drainage to the wall in accordance with HA requirements.

5.3 It is considered that with correct design and workmanship, and by following the recommendations of this Certificate, normally accepted tolerances for the construction of retaining walls can be achieved. However, where the alignment of the vertical face is critical, consideration may be given to providing a brickwork skin, or similar, to the facing units.

5.4 The design of the retaining wall as a whole unit must ensure that the facing units can provide

adequate anchorage to the geogrid and provide local support to the soil between the layers of geogrid.

## 6 Mechanical properties

### Long-term connection strength ( $T_{conn}$ )

6.1 A value for the long-term connection strength of the wall system (see Table 1) at various wall heights has been derived by performing a series of short-term tests in line with the National Concrete Masonry Association *Design Manual for Segmental Retaining Walls* (Second Edition, 1997). From the results of these tests, a connection efficiency, expressed as a percentage, has been applied to the values of tensile creep rupture strength,  $T_{cr}$  of the grid (as given in BBA Certificate No 99/R108).

| Geogrid grade           | $T_{cr}$<br>( $kNm^{-1}$ ) | Wall height<br>(m) | $T_{conn}$<br>( $kNm^{-1}$ ) |
|-------------------------|----------------------------|--------------------|------------------------------|
| <i>Standard blocks:</i> |                            |                    |                              |
| SR55                    | 22.5                       | 0.0–0.9            | 5.3                          |
|                         |                            | 1.0–1.9            | 9.2                          |
|                         |                            | 2.0–6.0            | 10.5                         |
| SR80                    | 31.6                       | 0.0–0.3            | 8.1                          |
|                         |                            | 0.4–0.9            | 9.0                          |
|                         |                            | 1.0–1.9            | 12.2                         |
|                         |                            | 2.0–2.9            | 17.4                         |
|                         |                            | 3.0–6.0            | 19.5                         |
| SR110                   | 43.9                       | 0.0–1.2            | 8.5                          |
|                         |                            | 1.3–2.9            | 12.6                         |
|                         |                            | 3.0–3.9            | 19.2                         |
|                         |                            | 4.0–4.9            | 22.7                         |
|                         |                            | 5.0–6.0            | 25.5                         |
|                         |                            |                    |                              |
| <i>Compac blocks:</i>   |                            |                    |                              |
| SR55                    | 22.5                       | 0.0–0.3            | 4.8                          |
|                         |                            | 0.4–0.9            | 5.8                          |
|                         |                            | 1.0–1.9            | 7.4                          |
|                         |                            | 2.0–2.9            | 9.1                          |
|                         |                            | 3.0–3.9            | 10.1                         |
|                         |                            | 4.0–6.0            | 11.6                         |
| SR80                    | 31.6                       | 0.0–0.3            | 5.5                          |
|                         |                            | 0.4–0.9            | 7.3                          |
|                         |                            | 1.0–1.9            | 8.7                          |
|                         |                            | 2.0–2.9            | 11.4                         |
|                         |                            | 3.0–3.9            | 13.9                         |
|                         |                            | 4.0–4.9            | 16.3                         |
| SR110                   | 43.9                       | 0.0–0.6            | 7.7                          |
|                         |                            | 0.7–2.1            | 11.0                         |
|                         |                            | 2.2–2.9            | 14.4                         |
|                         |                            | 3.0–3.9            | 16.5                         |
|                         |                            | 4.0–4.9            | 18.8                         |
|                         |                            | 5.0–6.0            | 21.0                         |

### Design strength of Forticrete wall system

6.2 To evaluate the overall design strength of the wall system, it is necessary to consider both the design strength of the grid ( $T_{Dgrid}$ ) and the design strength of the connection ( $T_{Dconn}$ ).

### Design strength $T_{Dgrid}$

6.3  $T_{Dgrid}$  should be calculated for both the ultimate and serviceability limit states using the information contained in BBA Certificate No 99/R108.

### Design strength $T_{Dconn}$

6.4 For the ultimate limit state, the connection design strength should be calculated by using:

$$T_{Dconn} = \frac{T_{conn}}{f_m f_n}$$

6.5 For all designs involving the use of the wall system the value of the partial factor for ramification of failure,  $f_n$ , should be in accordance with BD 70/03.

6.6 The values of the partial material factor,  $f_m$ , sub-components should be taken from Table 2.

| Partial material factor component | Value               |
|-----------------------------------|---------------------|
| $f_m 11$                          | 1.00                |
| $f_m 121$                         | 1.05                |
| $f_m 122$                         | 1.00                |
| $f_m 212$                         | 1.00 <sup>(1)</sup> |
| $f_m 22$                          | 1.05 <sup>(2)</sup> |

(1) Short-term installation damage effects are deemed to have been taken into account through the method of deriving the value,  $T_{conn}$ .

(2) A value of 1.05 applies to soils with a pH value in the range 2.0 to 12.0.

6.7 The design load the connection must resist ( $T_i$ ) is to be calculated using prescribed load factors recommended in BD 70/03. For all designs including the wall system the minimum value of load factor is to be 1.5. In all cases  $T_i$  must be  $\leq T_{Dconn}$ .

## 7 Durability

The system has been assessed as being capable of providing a design life of 120 years for normal reinforced soil-retaining wall applications. Sulphate-resisting Portland cement should be used where facing units are required to be embedded in aggressive soils.

## Installation

### 8 Procedure

8.1 Formation levels are prepared and a suitable concrete foundation is laid to the correct level for the first course of facing units. The first course of facing units should always be laid on a mortar bed, or bedded into the fresh concrete in order to achieve the required accuracy in line and level. Facing units should be lifted and located by two men using appropriate lifting equipment.

8.2 All voids inside, between and behind the facing units, should be filled with a selected granular fill complying with the specification in section 1.9 of this Detail Sheet.

8.3 Backfill may then be placed and compacted to correspond with the height required for the first geogrid layer. Compaction should always commence nearest the facing units, working away towards the free end of the grid. The compacted fill must be generally level to receive the geogrids.

8.4 To avoid excessive movement of the wall facing, heavy compaction plant should not be employed within two metres of the facing units, where the depth of fill before each pass may be less than 150 mm to suit the compaction plant used (MCHW1, clause 622.7). Outside of this area, installation and compaction of the Tensor SR geogrid should be as described in section 7 of BBA Certificate No 99/R108.

8.5 The GRP dowels should be securely inserted over half their length into the appropriate paired holes in the facing units (see Figure 1). The dowels should be placed in the holes nearest the front face of the units for vertical walls and in the holes farthest from the front face to achieve a pre-determined batter to the wall.

8.6 A suitable length of geogrid is cut from a roll and loose longitudinal ribs are trimmed to within 10 mm of a transverse bar, to ensure that no grid protrudes from the front face of the wall once the geogrid has been positioned.

8.7 The transverse bar of the geogrid is located over the GRP dowels (see Figure 2). The next course of facing units is placed over the GRP dowels locating the kidney-shaped recesses over the pins. The unit is centred over the two underlying units and the facing unit is pulled towards the front face of the wall until it makes full contact with both pins.

8.8 The geogrid is tensioned and backfill placed by mechanical plant, with an opening bucket, such that it causes the fill to cover the grid reasonably uniformly (see Figure 3). The backfill is then compacted as described in section 8.3.

8.9 Connection of lengths of geogrid (other than at the facing units) should be by Tensor Bodkins as described and detailed in BBA Certificate No 99/R108.

8.10 The procedure is repeated until the required level for the coping facing unit is reached.

## Technical Investigations

The following is a summary of the technical investigations carried out on the Forticrete Keystone Reinforced Soil Retaining Wall and Bridge Abutment System.

### 9 Investigations

9.1 The manufacturing process for the concrete facing units was examined, including the methods adopted for quality control, and details were obtained of the quality and composition of the materials used.

9.2 An examination was made of test data relating to:

- compressive strength of concrete block facing units
- durability
- performance of the retaining wall system under fire test conditions
- assessment, including product specific testing, of the connection strength between the Tensor SR geogrids and facing units using the interlock connector.

9.3 Visits were made to installations in progress to assess the practicability and ease of construction of the system.

9.4 Proposed design methods were assessed in relation to the requirements of BD 70/03 and the National Concrete Masonry Association *Design Manual for Segmental Retaining Walls* (Second Edition 1997) National Concrete Masonry Association, Herndon, Virginia, USA.

## Bibliography

BS 6073-2 : 1981 *Precast concrete masonry units — Method for specifying precast concrete masonry units*

BS 7263-1 : 2001 *Precast concrete flags, kerbs, channels, edgings and quadrants — Part 1 — Precast, unreinforced concrete paving flags and complementary fittings — Requirements and test methods*

BS EN 12620 : 2002 *Aggregates for concrete*

BS EN 12878 : 1999 *Pigments for the colouring of building materials based on cement and/or lime — Specifications and methods of test*

BD 70/03 *Strengthened Reinforced Soils and other Fills for Retaining Walls and Bridge Abutments*

Manual of Contract Documents for Highway Works, Volume 1 : *Specification for Highway Works* : May 2001 edition



On behalf of the British Board of Agrément

Date of issue: 16th January 2004

Chief Executive

Blank page

# Electronic Copy

---

**British Board of Agrément**

P O Box No 195, Bucknalls Lane  
Garston, Watford, Herts WD25 9BA  
Fax: 01923 665301

©2004

e-mail: [mail@bba.star.co.uk](mailto:mail@bba.star.co.uk)  
website: [www.bbacerts.co.uk](http://www.bbacerts.co.uk)



For technical or additional information,  
contact the Certificate holder (see  
front page).  
For information about the Agrément  
Certificate, including validity and  
scope, tel: Hotline 01923 665400,  
or check the BBA website.



Forticrete Ltd

**FORTICRETE UNIVERSAL REINFORCED  
SOIL RETAINING WALL AND BRIDGE  
ABUTMENT SYSTEM**

Roads and Bridges  
Certificate No 04/R137  
**DETAIL SHEET 3**

## Product



- THIS DETAIL SHEET RELATES TO THE FORTICRETE UNIVERSAL REINFORCED SOIL RETAINING WALL AND BRIDGE ABUTMENT SYSTEM, COMPRISING THE STANDARD OR COMPAC CONCRETE BLOCK FACING UNITS IN COMBINATION WITH TENSAR 55RE, 80RE AND 120RE GEOGRIDS.

- The blocks and geogrids are connected by a combination of polymeric comb connectors and frictional-fill material.
- The Forticrete Universal system is marketed in the United Kingdom by Forticrete Ltd.

*This Detail Sheet must be read in conjunction with the Front Sheet, which gives HA requirements and the Conditions of Certification.*

## Technical Specification

### 1 Description

1.1 The system comprises:

- Forticrete Universal concrete block facing units
- polymeric comb connectors
- Tensar 55RE, 80RE and 120RE geogrids
- selected granular fill to all voids, in, around and behind the facing units
- pultruded GRP dowels.

### Forticrete Universal concrete block facing units

1.2 The concrete block facing units covered by this Certificate are the ClassicFace or RockFace types (see Figure 1). All units are manufactured to the same concrete mix specification.

Figure 1 Types of block

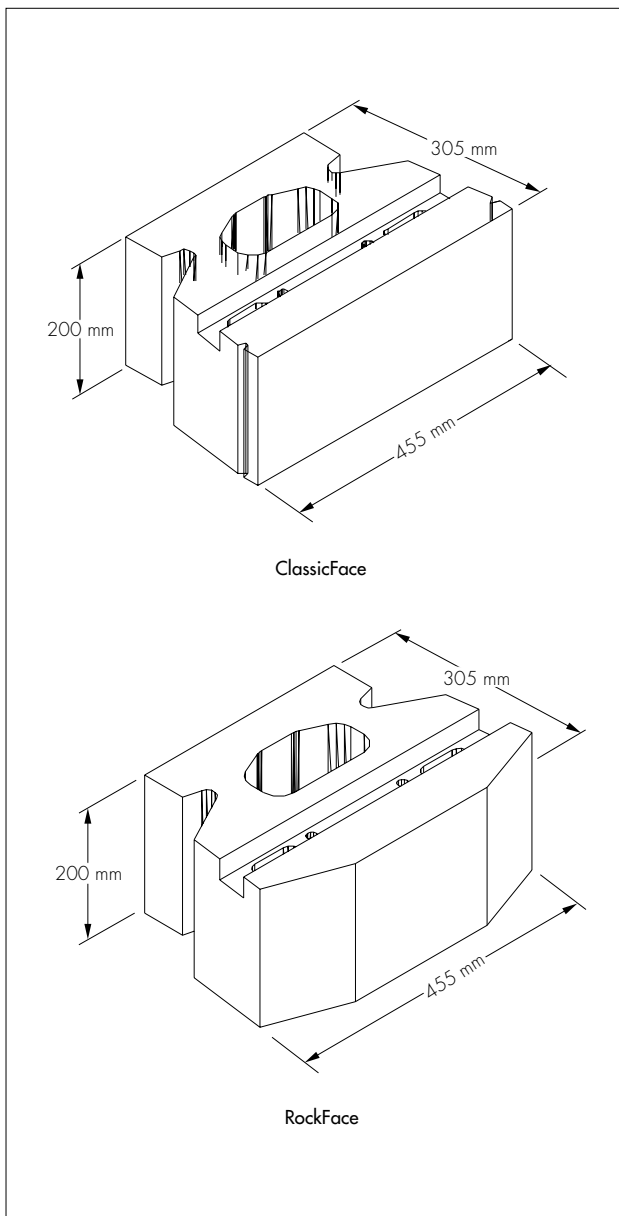

1.3 All pigments used for the coloration of the concrete blocks comply with BS EN 12878 : 1999.

1.4 Facing units are manufactured in block machines, where mechanical vibratory compaction and sizing is used with semi-dry concrete to achieve the specified minimum compressive strength, water absorption and block shape:

- minimum concrete strength —  $30 \text{ Nmm}^{-2}$  at 28 days
- water absorption — a maximum of 6% when tested in accordance with the method of BS 7263-1 : 2001, Annex C
- density range — average value to be a minimum of  $1925 \text{ kgm}^{-3}$  when tested in accordance with the method of BS 6073-2 : 1981, Appendix C.

1.5 The concrete mix specification comprises a minimum cement content of  $365 \text{ kgm}^{-3}$  and a maximum water/cement ratio of 0.5.

1.6 The blocks are cured for a minimum 24-hour period in a temperature- and humidity-controlled internal environment.

1.7 Factory production control is undertaken throughout all stages of manufacture. Checks include:

- formalised daily patrol checks
- formalised recording of use of correct concrete mix specification
- visual checks on appearance of demoulded units and hourly measurements of block heights
- compressive strength and measured density recording at seven days on three samples taken from each block type produced per day
- formalised acceptance of product after completion of all quality control checks (minimum period before products released for use is seven days).

### Polymeric comb connectors

1.8 The polymeric comb connectors are manufactured from polyethylene, to one specification, by a Forticrete Ltd approved sub-contractor (see Figure 2).

Figure 2 Polymeric connectors

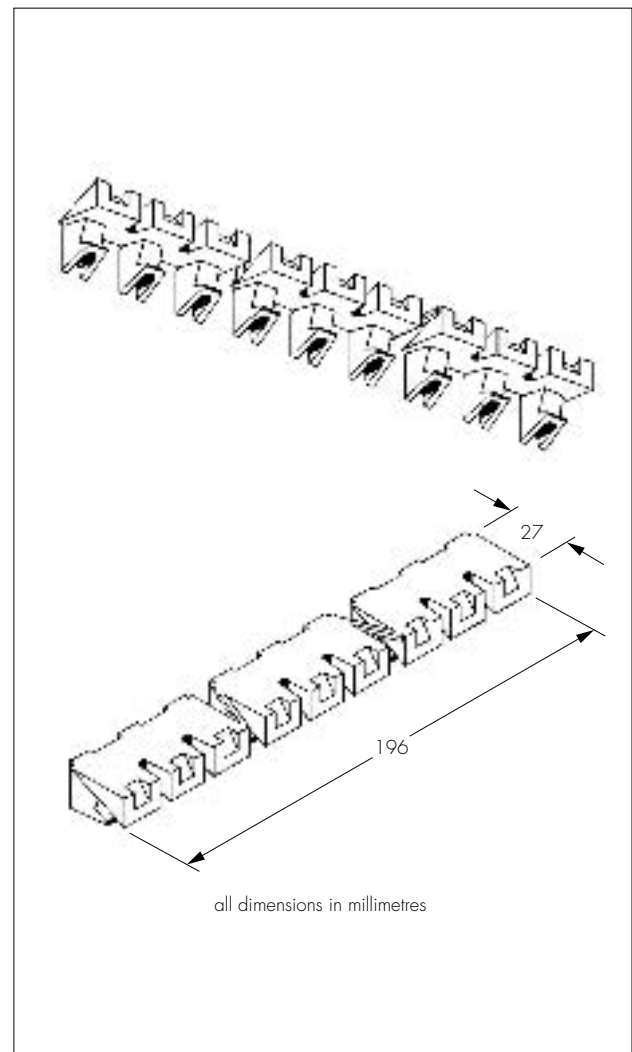

### Tensor 55RE, 80RE and 120RE geogrids

1.9 The technical specification must comply with BBA Certificate No 99/R109.

#### Pultruded GRP dowels

1.10 The GRP dowels are manufactured by a pultrusion process and supplied by Pultron Composites Limited (to approved specifications) to achieve both the required durability and long-term mechanical properties. They are 132 mm in length and have a diameter of 12 mm.

#### Selected granular fill to all voids in, around and behind the facing units

1.11 The granular fill material to all voids must be a crushed, coarse aggregate graded 4 mm to 20 mm in accordance with BS EN 12620 : 2002. Pea gravel or other rounded aggregates must not be used.

#### Fill

1.12 The fill material used in the structure should comply with the requirements of one of the class 6I, 6J, 7B, 7C or 7D of the HA specification (MCHW1 and 2) and with BD 70/03.

## 2 Delivery to site, handling and storage

#### Facing units

2.1 The facing units are delivered to site on shrink-wrapped pallets. They carry a manufacturer's label or marking identifying the product type and batch code. Pallets should not be stacked more than two high.

2.2 To prevent damage, care should be taken in transit and handling. During prolonged periods of storage on site the units should remain covered on pallets.

#### Polymeric comb connectors

2.3 The polymeric connectors are delivered to site in polyethylene bags containing 250 units. The bags are labelled, to show the manufacturer, product type and batch code. The connectors should remain within their packaging until use is imminent, since any damage or dirt accumulation will compromise the structural integrity of the connection.

### Tensor 55RE, 80RE and 120RE geogrids

2.4 The geogrids should be handled and stored generally in accordance with HA requirements and BBA Certificate No 99/R109.

#### Pultruded GRP dowels

2.5 The GRP dowels are delivered to site in boxes. Care should be taken in storage, transit and handling on site.

## 3 General

3.1 The Forticrete Universal Reinforced Soil Retaining Wall and Bridge Abutment System is satisfactory for use in providing reinforced soil retaining walls. Walls up to a maximum height of 10 metres are covered by this Certificate. Structural stability is achieved through the frictional interaction and interlock of the soil particles and the geogrid and by the mechanical connection of the geogrid to the facing units via the polymeric comb connectors (see Figure 3).

Figure 3 Method of connecting geogrid to facing unit

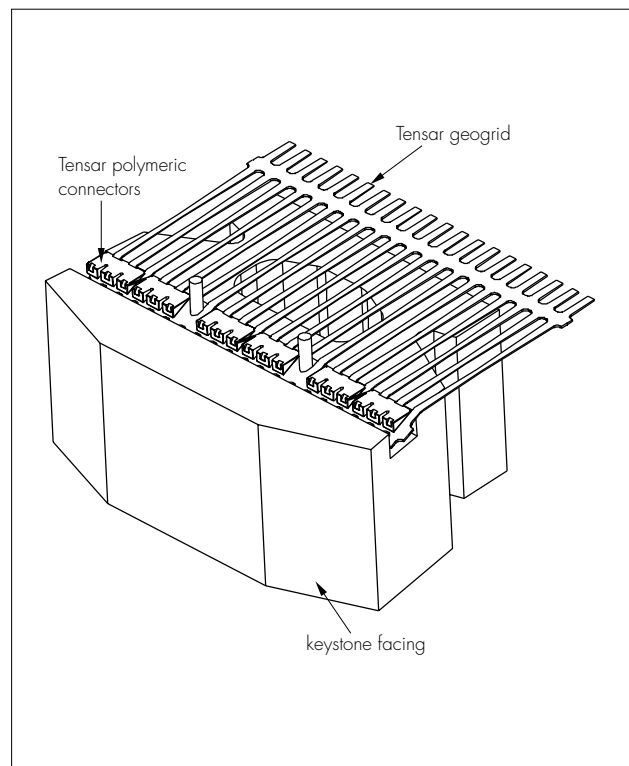

3.2 The BBA has not assessed this system for supporting parapet loading caused by vehicle collision at the top of the facing units. When applicable this aspect of a design would require separate consideration and approval by the HA.

3.3 In common with all retaining walls of this type, supplementary details are required if there is a risk of dislodgement of the top courses.

3.4 The system should be protected against horizontal impact loads caused by possible vehicle collision with the lower facing units of the wall.

3.5 Design of the reinforced soil wall must be in accordance with HA requirements and carried out by a suitably qualified engineer.

3.6 Prior to the commencement of the work, the designer shall submit to the HA nominee via the main contractor, relevant design and check

certificates in accordance with current HA requirements and, as required, details:

- working drawings
- calculations
- source of fill material
- acceptable moisture content of fill material at time of placement
- method of tightening geogrids prior to fill placing
- sequence of placing fill material
- estimated movements of facing units during filling and compaction operations
- tolerance on the position of finished line of the wall.

## 4 Practicability of installation

4.1 The system is installed easily provided all requirements of BBA Certificate No 99/R109 and section 8 of this Certificate are complied with.

4.2 It is important that the first course of concrete block units is laid accurately to the correct line and level to avoid compounding errors in alignment as the wall is built.

4.3 Where accurate cutting of facing units is required on site, this should be carried out by disc-cutting techniques.

4.4 To avoid problems with the level of the facing units, the geogrid should not be lapped when attached to the GRP dowels. Adjacent strips of geogrids should be positioned to abut.

## 5 Design considerations

### General

5.1 Walls utilising the system must be designed in accordance with BD 70/03.

5.2 Adequate consideration must be given to the provision of drainage to the wall in accordance with HA requirements.

5.3 It is considered that with correct design and workmanship, and by following the recommendations of this Certificate, normally accepted tolerances for the construction of retaining walls, as defined in Table 23 of BS 8006 : 1995, can be achieved. However, where the alignment of the vertical face is critical, consideration may be given to providing a brickwork skin, or similar, to the facing units.

5.4 The design of the retaining wall as a whole unit must ensure that the facing units can provide adequate anchorage to the geogrid and provide local support to the soil between the layers of geogrid.

5.5 To prevent interface shear, all blocks must be interconnected with the fibreglass dowels, whether or not a reinforcing layer is to be used.

## 6 Mechanical properties

### Long-term connection strength ( $T_{conn}$ )

6.1 A value for the long-term connection strength of the wall system (see Table 1) has been derived by performing a series of short-term tests in line with the National Concrete Masonry Association *Design Manual for Segmental Retaining Walls* (Second Edition, 1997). From the results of these tests, a connection efficiency, expressed as a percentage, has been applied to the values of tensile creep rupture strength,  $T_{cr}$  of the grid (as given in BBA Certificate No 99/R109).

Table 1 Long-term connection strength,  $T_{conn}$

| Geogrid grade | $T_{cr}$ (kNm <sup>-1</sup> ) | Wall height (m) | $T_{conn}$ (kNm <sup>-1</sup> ) |
|---------------|-------------------------------|-----------------|---------------------------------|
| 55RE          | 28.7                          | 0.0–1.4         | 23.6                            |
|               |                               | 1.5–3.8         | 24.2                            |
|               |                               | 3.9–6.2         | 22.9                            |
|               |                               | 6.3–8.1         | 23.5                            |
|               |                               | 8.2–10.0        | 20.9                            |
| 80RE          | 38.2                          | 0.0–1.0         | 31.7                            |
|               |                               | 1.1–2.1         | 30.7                            |
|               |                               | 2.2–3.1         | 32.2                            |
|               |                               | 3.2–5.2         | 31.5                            |
|               |                               | 5.3–7.0         | 32.3                            |
|               |                               | 7.1–8.7         | 30.8                            |
|               |                               | 8.8–10.0        | 26.8                            |
| 120RE         | 54.8                          | 0.0–2.0         | 50.0                            |
|               |                               | 2.1–4.0         | 49.7                            |
|               |                               | 4.1–5.9         | 49.9                            |
|               |                               | 6.0–7.8         | 50.7                            |
|               |                               | 7.9–9.6         | 48.3                            |
|               |                               | 9.7–10.0        | 45.0                            |

### Design strength of Forticrete wall system

6.2 To evaluate the overall design strength of the wall system, it is necessary to consider both the design strength of the grid ( $T_{Dgrid}$ ) and the design strength of the connection ( $T_{Dconn}$ ).

### Design strength $T_{Dgrid}$

6.3  $T_{Dgrid}$  should be calculated for both the ultimate and serviceability limit states using the information contained in BBA Certificate No 99/R109.

### Design strength $T_{Dconn}$

6.4 For the ultimate limit state, the connection design strength should be calculated by using:

$$T_{Dconn} = \frac{T_{conn}}{f_m f_n}$$

6.5 For all designs involving the use of the wall system the value of the partial factor for ramification of failure,  $f_n$ , should be in accordance with BD 70/03.

6.6 The values of the partial material factor,  $f_m$ , sub-components should be taken from Table 2.

Table 2 Partial material factor,  $f_m$ , sub-component factors for evaluating  $T_{Dconn}$

| Partial material factor component | Value               |
|-----------------------------------|---------------------|
| $f_m$ 11                          | 1.00                |
| $f_m$ 121                         | 1.05                |
| $f_m$ 122                         | 1.00                |
| $f_m$ 212                         | 1.00 <sup>(1)</sup> |
| $f_m$ 22                          | 1.05 <sup>(2)</sup> |

(1) The long-term effects of the short-term installation damage are deemed to have been taken into account through the method of deriving the value,  $T_{conn}$ .

(2) A value of 1.05 applies to soils with a pH value in the range 2.0 to 12.0.

6.7 The design load the connection must resist ( $T_i$ ) is to be calculated using prescribed load factors recommended in BD 70/03. For all designs including the wall system the minimum value of load factor is to be 1.5. In all cases  $T_i$  must be  $\leq T_{Dconn}$ .

## 7 Durability

The system has been assessed as being capable of providing a design life of 120 years for normal reinforced soil-retaining wall applications. Sulphate-resisting Portland cement should be used where facing units are required to be embedded in aggressive soils, as determined by reference to BRE Digest 250 : August 2001, *Concrete in aggressive ground*.

## Installation

### 8 Procedure

8.1 Formation levels are prepared and a suitable concrete foundation is laid to the correct level for the first course of facing units. The first course of facing units should always be laid on a mortar bed, or bedded into the fresh concrete in order to achieve the required accuracy in line and level. Facing units should be lifted and located by two men using appropriate lifting equipment.

8.2 The GRP dowels should be securely inserted to over half their length into the appropriate paired holes in the facing units (see Figure 1). All blocks must be inter-connected with fibreglass dowels, whether or not a geogrid layer is to be inserted.

8.3 Facing units should be laid until the required level of the first layer of geogrid. Fill all voids, in, between and immediately behind the facing units with the granular fill material. The drainage zone should extend a minimum of 300 mm behind the facing units. Backfill may then be placed and compacted to the level of the first layer of geogrid.

8.4 Fill should be placed by mechanical plant, but in order to avoid excessive movement of the wall facing, heavy compaction plant should not be employed within two metres of the facing units, where the depth of fill before each pass may be less than 150 mm to suit the compaction plant used (MCHW1, clause 622.7). Outside of this area, installation and compaction of the Tensar RE geogrid should be as described in section 7 of BBA Certificate No 99/R109.

8.5 The compacted fill should be generally level to receive the geogrid and the blocks swept to remove all debris. A suitable length of geogrid should be cut from the roll and any protruding ribs trimmed back to within 10 mm of the transverse bar. The prepared end of the grid is placed over the rebate in the block and locate the polymeric connectors around the transverse bar. Each aperture of the geogrid must be covered by a connector.

8.6 The assembly is positioned neatly into the rebate of the facing unit and push down firmly. The next course of blocks is placed over the GRP dowels, locating the kidney-shaped recesses over the pins, and pushed towards the front of the structure until it makes full contact with both pins.

8.7 Depending upon the design, up to three courses of facing units may be laid before inserting a further layer of geogrid, (606 mm maximum vertical spacing).

8.8 The geogrid should be lightly tensioned using the tensioning beam supplied, so that the polymeric connectors are up against the rear of the rebate.

8.9 The procedure is repeated until the required level for a coping facing unit is reached.

8.10 Connection of lengths of geogrid (other than at the facing units) should be by Tensar Bodkins as described and detailed in BBA Certificate No 99/R109.

The following is a summary of the technical investigations carried out on the Forticrete Universal Reinforced Soil Retaining Wall and Bridge Abutment System.

### 9 Investigations

9.1 The manufacturing process for the concrete facing units was examined, including the methods adopted for quality control, and details were obtained of the quality and composition of the materials used.

9.2 An examination was made of test data relating to:

- compressive strength of concrete block facing units
- durability
- performance of the retaining wall system under fire test conditions
- assessment, including product specific testing, of the connection strength between the Tensar RE geogrids and facing units using the polymeric connector.

9.3 Visits were made to installations in progress to assess the practicability and ease of construction of the system.

9.4 Proposed design methods were assessed in relation to the requirements of BD 70/03 and the National Concrete Masonry Association *Design Manual for Segmental Retaining Walls* (Second Edition 1997) National Concrete Masonry Association, Herndon, Virginia, USA.

BS 6073-2 : 1981 *Precast concrete masonry units — Method for specifying precast concrete masonry units*

BS 7263-1 : 2001 *Precast concrete flags, kerbs, channels, edgings and quadrants — Part 1 — Precast, unreinforced concrete paving flags and complementary fittings — Requirements and test methods*

BS 8006 : 1995 *Code of practice for strengthened/reinforced soils and other fills*

BS EN 12620 : 2002 *Aggregates for concrete*

BS EN 12878 : 1999 *Pigments for the colouring of building materials based on cement and/or lime — Specifications and methods of test*

BD 70/03 *Strengthened/Reinforced Soils and other Fills for Retaining Walls and Bridge Abutments*

Manual of Contract Documents for Highway Works, Volume 1 *Specification for Highway Works*, August 1998 (as amended)

Manual of Contract Documents for Highway Works, Volume 2 *Notes for Guidance on the Specification for Highway Works*, August 1998 (as amended)



On behalf of the British Board of Agrément

Date of issue: 14th June 2004

A handwritten signature in black ink, appearing to read 'P. C. Newson'.

Chief Executive

Blank page

# Electronic Copy

---

**British Board of Agrément**

P O Box No 195, Bucknalls Lane  
Garston, Watford, Herts WD25 9BA  
Fax: 01923 665301

©2004

e-mail: [mail@bba.star.co.uk](mailto:mail@bba.star.co.uk)  
website: [www.bbacerts.co.uk](http://www.bbacerts.co.uk)



For technical or additional information,  
contact the Certificate holder (see  
front page).  
For information about the Agrément  
Certificate, including validity and  
scope, tel: Hotline 01923 665400,  
or check the BBA website.