



FloPlast Limited

Sheppey Way
Howt Green
Sittingbourne
Kent ME9 8QT

Tel: 01795 431731 Fax: 01795 431188

**Agrément
Certificate
No 00/3771**

Designated by Government
to issue
European Technical
Approvals

FLOPLAST WHITE PVC-U ROOF TRIM SYSTEM

Accessoires en PVC-U pour toits
Zubehör (von PVC-U) für Dächer

Product



• THIS CERTIFICATE RELATES TO THE FLOPLAST WHITE PVC-U ROOF TRIM SYSTEM, COMPRISING WHITE FASCIA, SOFFIT AND BARGE BOARDS, SOFFIT VENTILATOR, AND ACCESSORIES.

• The system is for external use at the roofline as a substitute for timber or other conventional materials.

• It is essential that the system is installed in accordance with the manufacturer's instructions and the Design Data and Installation parts of this Certificate.

Regulations

1 The Building Regulations 2000 (England and Wales)



The Secretary of State has agreed with the British Board of Agrément the requirements of the Building Regulations to which roofline systems can contribute in achieving compliance. In the opinion of the BBA, the FloPlast White PVC-U Roof Trim System, if used in accordance with the provisions of this Certificate, will meet or contribute to meeting the relevant requirements.

Requirement: C4
Comment:

Resistance to weather and ground moisture

The system will contribute to providing protection against the penetration of moisture to the inner surface of the building on which it is installed. See section 7.1 of this Certificate.

Requirement: F2
Comment:

Condensation in roofs

When used in accordance with this Certificate, FloPlast soffit ventilators can contribute in enabling a roof to meet this Requirement. See sections 7.4 to 7.14 of this Certificate.

Requirement: Regulation 7
Comment:

Materials and workmanship

The components of the system are acceptable. See section 12.1 of this Certificate.

Electronic Copy

2 The Building Standards (Scotland) Regulations 1990 (as amended)



In the opinion of the BBA, the FloPlast White PVC-U Roof Trim System, if used in accordance with the provisions of this Certificate, will satisfy or contribute to satisfying the various Regulations and related Technical Standards as listed below.

Regulation:	10	Fitness of materials
Standard:	B2.1	Selection and use of materials and components
Comment:		The components of the system are acceptable. See section 12.1 of this Certificate
Regulation:	17	Resistance to moisture
Standard:	G3.1	Resistance to precipitation
Comment:		The system will provide adequate protection against the penetration of moisture to the inner surface of the building on which it is installed. See section 7.1 of this Certificate.
Regulation:	18	Resistance to condensation
Standard:	G4.1	Interstitial condensation
Comment:		FloPlast soffit ventilators can contribute towards enabling a roof to meet this Standard. See sections 7.4 to 7.14 of this Certificate.

3 The Building Regulations (Northern Ireland) 1994 (as amended)



In the opinion of the BBA, FloPlast White PVC-U Roof Trim System, if used in accordance with the provisions of this Certificate, will satisfy or contribute to satisfying the various Building Regulations as listed below.

Regulation:	B2	Fitness of materials and workmanship
Comment:		The components of the system are acceptable. See section 12.1 of this Certificate.
Regulation:	C5	Resistance to ground moisture and weather
Comment:		The system will contribute to providing protection against the penetration of moisture to the inner surface of the building on which it is installed. See section 7.1 of this Certificate.
Regulation:	C7	Condensation
Comment:		FloPlast soffit ventilators can contribute towards enabling a roof to meet this Regulation. See sections 7.4 to 7.14 of this Certificate.

4 Construction (Design and Management) Regulations 1994

Information in this Certificate may assist the client, planning supervisor, designer and contractors to address their obligations under these Regulations.

See sections: *8 Practicability of installation and 13 General (13.2).*

Technical Specification

5 Description

5.1 The FloPlast White PVC-U Roof Trim System is for external use at the roofline as a substitute for timber or other conventional materials.

5.2 The system comprises a range of white cellular PVC-U (PVC-UE) boards, including vented soffits (see Figure 1), together with matching ancillary components, including a rigid soffit ventilator and other extruded trims, and injection-moulded joint covers (see Figures 2 and 3).

5.3 The soffit ventilators, which include vented cellular boards and a ventilator strip, provide a means of ventilating the roof void.

5.4 The products are available in white.

5.5 The cellular boards comprise a closed cell cellular PVC-UE core beneath an outer weathering

impact modified PVC-U skin. The soffit ventilator and other extruded trims are composed of impact modified PVC-U and the injection mouldings of PVC-U.

5.6 Characteristics of the boards are shown in Table 1.

Table 1 Characteristics of boards

	Universal board	Ogee board	Multi-purpose board	Mammoth board (including Ogee)	Hollow soffit board
standard length (m)	5	5	5	5	5
nominal thickness (mm)	10	10	10	18	10
minimum thickness of outer skin (mm)	0.6	0.6	0.6	0.6	—
average density (kgm ⁻³)	420	420	420	420	—

Figure 1 Cellular boards

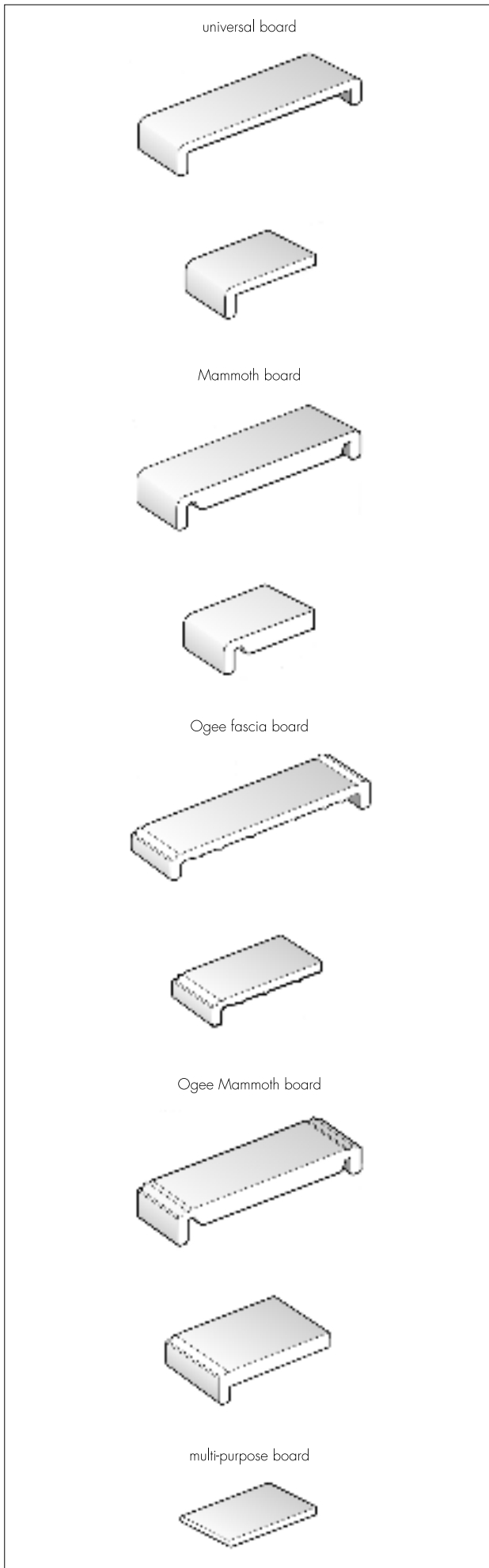

Figure 2 Soffit boards

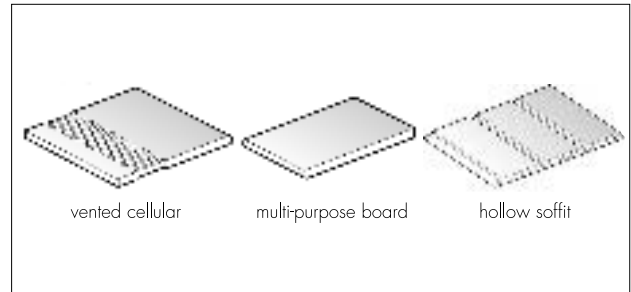
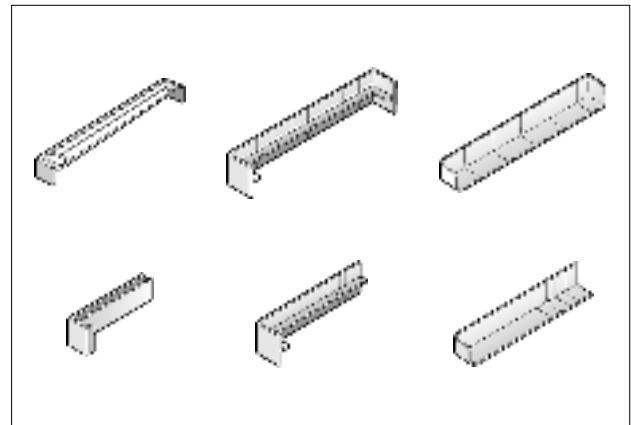

Figure 3 Injection-moulded trims



5.7 The cellular boards are manufactured by co-extruding a high impact PVC-U compound onto a foamable PVC-U compound, cooling and forming to section. Cellular PVC-U is formed during the process by the evolution of gas from sodium bicarbonate present in the foamable PVC-U compound. A clear polythene film is applied to the outer face.

5.8 The trims are manufactured using conventional extrusion and injection moulding techniques.

5.9 Continuous quality control is undertaken during the manufacture of cellular boards to include checks on appearance, colour, dimensions, weight per metre, skin thickness and impact strength, and on rigid trims to include checks on appearance, colour, dimensions, weight, heat reversion and heat ageing.

5.10 A range of A4 (Steel No 1.4401, BS EN 10088-2 : 1995) stainless steel nails/pins of minimum length 30 mm and minimum diameter 2 mm with white plastic heads are supplied by the manufacturer for fixing components of the system to the rafter feet, noggings or other timber substrates. Silicone sealants are used to fix fascia trims and end caps and silicone sealants are used to close gaps between substrate and roof trims.

6 Delivery and site handling

6.1 The fascia, barge board, soffit and trim profiles are delivered to site in packs sealed in polyethylene sleeves bearing the FloPlast product marking. Pack quantities vary dependent upon the type of profile.

6.2 Unloading should be carried out by hand to avoid damage to the components, which should be stored flat in their protective wrapping, on a clean, level surface. Stacks must not exceed 1 m in height and should be restrained to prevent collapse. If stored externally the pack should be kept under cover.

7 General



7.1 The FloPlast White PVC-U Roof Trim System is suitable for use externally to provide a protective and decorative trim at the roofline where timber or other conventional materials would normally be used.

7.2 The system must be fixed only to structurally sound building substrates, at centres not exceeding 600 mm. Rafter feet and gable ladders should be adequately supported by noggings to ensure rigidity. Timber roof structures, to which the system is fixed, must be designed and constructed in accordance with the relevant Building Regulations and, as appropriate, in compliance with one of the following technical specifications:

BS 5268-2 : 1996

BS 5268-3 : 1998

7.3 The cellular PVC-UE components have a similar coefficient of thermal expansion to that of conventional solid PVC-U. A 5 mm gap should be provided at the end of each board, at the joint trim (ie 10 mm between boards), to allow for movement. Care should be taken not to install the system in extremes of temperature. The recommended temperature for installation is between 5°C and 25°C.

Ventilation



7.4 The soffit ventilators can contribute towards providing the necessary roof space ventilation. Guidance on the provision of adequate ventilation is given in the 1995 edition of the Approved Document F2 *Condensation in roofs*, to the Building Regulations 2000 (England and Wales), and in BS 5250 : 1989(1995).

7.5 When providing roof space ventilation it is essential that the airway should not be allowed to become blocked by the loft insulation. This may be achieved by the use of a suitable BBA approved insulation retainer producing an air passage with an effective area (geometric free area) at least equal to that of the soffit ventilator used.

7.6 The vented soffit board has a vented area of 10200 mm² per metre run (which is equivalent to a continuous vent 10.2 mm wide at the eaves) and is suitable for the applications given in section 7.8.

7.7 The soffit ventilator strip (without mesh) has a vented area of 25 000 mm² per metre run (equivalent to a continuous vent 25 mm wide at the

eaves), and is suitable for applications given in sections 7.8 to 7.10.

7.8 For roofs with a pitch of 15° or more, where both the ceiling and insulation are horizontal, soffit ventilators with a minimum vented area of 10000 mm² per metre run, if used in accordance with section 7.5, can provide adequate ventilation to insulated loft spaces as set out in BS 5250 : 1989(1995), clause 9.4. The soffit ventilators should run along the eaves of the longest opposite sides of a rectangular roof to provide adequate cross-ventilation. The ventilators are suitable for use with traditional (semi-permeable) and high performance (impermeable) sarking felts. Consideration should be given to the use of high-level ventilation openings to increase the ventilation rate for roofs as recommended in BS 5250 : 1989(1995), clause 9.4. The use of high-level ventilation openings is strongly recommended in roofs with a pitch greater than 35° or roof spans in excess of 10 m.

7.9 For roofs where the ceiling follows the pitch of the roof, soffit ventilators with a minimum vented area of 25 000 mm² per metre run, if used in conjunction with suitable high-level ventilation, can provide adequately for roof voids as set out in BS 5250 : 1989(1995), clause 9.4. It is essential that a minimum unrestricted air space of 50 mm is maintained between the underside of the roof deck and the top of the insulation. Consideration should be given to the probability of the sarking felt bowing between rafters and it should be ensured that this does not reduce the gap between felt and insulation to less than 50 mm. Where there is an obstruction to the ventilation, eg rooflights or a change in pitch of roof, adequate ventilation, in accordance with the requirements of BS 5250 : 1989(1995), clause 9.4, should be provided above and below the obstruction using suitable ventilators. The required ventilation at high level and around obstructions may be achieved by using a suitable BBA approved ventilator.

7.10 For roofs with a pitch of less than 15°, soffit ventilators with a minimum vented area of 25 000 mm² per metre run, if used in accordance with section 7.5, can provide adequate ventilation to insulated roof voids as set out in BS 5250 : 1989(1995), clause 9.4. When providing roof space ventilation for flat roofs, it is essential that a minimum unrestricted air space of 50 mm is maintained between the underside of the roof deck and the top of the insulation. Ventilation should be provided along two opposite sides of the deck: where possible these should be the two longest sides in order to achieve maximum cross-ventilation. The recommendations contained in BS 5250 : 1989(1995), clause 9.4, should be followed when planning the provision of ventilation to flat roofs, especially where spans exceed 5 m, or for concrete deck roofs. Where a flat roof has a span

of greater than 10 m, or is not of a simple rectangular plan, more ventilation will be required, totalling at least 0.6% of the total area of the roof. It should be noted that cold flat roof construction is generally unacceptable in Scotland and not the preferred option elsewhere in the UK⁽¹⁾.

(1) See BRE Report BR 262 : 1994 *Thermal insulation : avoiding risks*.

7.11 Where soffit ventilators are used in lean-to or mono-pitched roofs, high-level ventilation, in accordance with BS 5250 : 1989(1995), clause 9.4, must be provided.

7.12 Where a pitched roof abuts a wall, additional high-level ventilation must be arranged to provide an open area at least equal to a 5 mm slot running the full length of the abutment.

7.13 The soffit ventilator sections meet NHBC requirements for protection against the ingress of birds, rodents or large insects.

7.14 The dimensions of the slots in the soffit ventilators are such that the risk of blockage is limited. However, blockage by insects and debris would impair their performance as vents and they should be examined occasionally and cleared if necessary.

8 Practicability of installation

8.1 The components of the system are easy to work using normal woodworking tools for cutting, drilling and shaping. Handsaws should have a fine-toothed blade. Hand-held and bench-mounted power tools with a carbide-tipped blade should be run at speeds similar to, or higher than, those normally used for timber.

8.2 Special training is not required to install the roof trim system correctly, provided the manufacturer's instructions and the procedures outlined in section 14 of this Certificate are followed. However, normal precautions should be taken when installing boards at roof level.

9 Strength and stability

9.1 When installed in accordance with this Certificate, the system will withstand, without damage or permanent deflection, the wind loads likely to be encountered in the United Kingdom. In exposed locations care should be taken to ensure that all profiles are adequately fixed.

9.2 The system has adequate resistance to the hard and soft body impacts likely to occur in practice.

9.3 PVC-U gutters, as specified in BS 4576-1 : 1989(1998), may be screw-fixed directly to the Mammoth boards. Gutter bracket spacings must not exceed 1 m; reduced spacings are recommended in the Scottish Highlands and similar exposed locations. Other lightweight gutters may

also be screw-fixed to the Mammoth board provided the maximum bracket loading, covered in BS 4576-1 : 1989(1998) is not exceeded. For other boards, all gutters should be fixed through the fascia to rafter end or other sound timber.

9.4 Apart from the exception detailed in section 9.3, the fascia boards are not loadbearing and must not be used independently to support fixtures such as roof tiles, gutters, other roof structure components, or television aerials. Suitably fixed telephone wires and power cables may be run along the boards, but the main brackets for these services should be fixed through the fascia to structurally sound timber.

10 Performance in relation to fire

10.1 When tested in accordance with BS 476-7 : 1997, the multi-purpose board achieved a Class 2Y rating; all other boards are expected to be similar except the hollow soffit which achieved a 1Y rating.

10.2 On exposure to fire, PVC-U tends to char and may fall away. The spread of flame along its surface is limited. It is unlikely that the roof trim system will significantly affect the overall fire performance of any roof in which it is installed.

10.3 Where it is normal practice to carry the eaves box over, between dwellings, it is important that the box is fire-stopped at compartment walls.

11 Maintenance

11.1 The system can be cleaned by washing with water and detergent. Solvent-based cleaners should not be used. The material can be cut and drilled, using normal woodworking tools, if repairs are required.

11.2 As with all PVC products, paint can adversely affect the impact strength of the cellular PVC-U sections, and the application of dark colours could lead to a risk of thermal distortion. Painting is therefore not recommended.

12 Durability

 12.1 Accelerated weathering tests indicate that FloPlast PVC-UE is as durable as conventional solid PVC-U and that profiles will retain adequate impact resistance for a period in excess of 20 years.

12.2 The system will retain its decorative qualities for a period in excess of 20 years with only minor changes in surface appearance.

12.3 Where the timber substrate is treated with a copper/chrome/arsenic preservative, care must be taken to ensure that sufficient time is allowed for complete fixation of the preservative (approximately seven days) to avoid corrosion of screws and nails used to fix the FloPlast components.

13 General

13.1 Installation must be carried out in accordance with the manufacturer's instructions and the requirements of this Certificate.

13.2 When using power tools to cut or shape the product, it is recommended that eye protection and a coarse-particle dust mask are used.

13.3 Fascia, soffit and barge boards should be fixed to preservative-treated, structurally sound timber at centres not exceeding 600 mm, using the nails supplied by the manufacturer. The nails should be selected to give a minimum of 40 mm penetration into the support timber.

13.4 Existing support timber should be checked and where necessary replaced or reinforced. Existing fascia board should not be used as a support/backing board for a cover board unless checked and found to be in sound condition.

13.5 Sarking felt should be checked to ensure that it is in good condition and extends onto the verge rafter and over a continuous tilting fillet and fascia into the gutter at the eaves. Damaged or worn felt should be replaced.

13.6 For the Mammoth board, gutter brackets may be fixed directly into the board at spacings not greater than 1 m, using the screws recommended by the manufacturer. The screws should penetrate the rear face of the board. For all other boards, gutter brackets are screwed through the fascia board into rafter feet or other timber support (see section 9.3).

13.7 Soffit ventilators should be selected so that the roof ventilation conforms to the relevant Building Regulations (see section 7).

14 Procedure

14.1 Selected boards and accessories are assembled and cut to size.

14.2 Rafter feet are cut to a line.

14.3 Noggings, soffit bearers, battens, eaves fillets, brackets and other additional timber supports are fixed to a sound substrate.

14.4 Protective films should be removed just prior to fixing, ie peeled off as nailing progresses along the board.

14.5 The summary for the installation details of fascia, soffit and barge boards (see sections 14.6 to 14.16) should be read with reference to the typical installation diagrams shown in Figure 4.

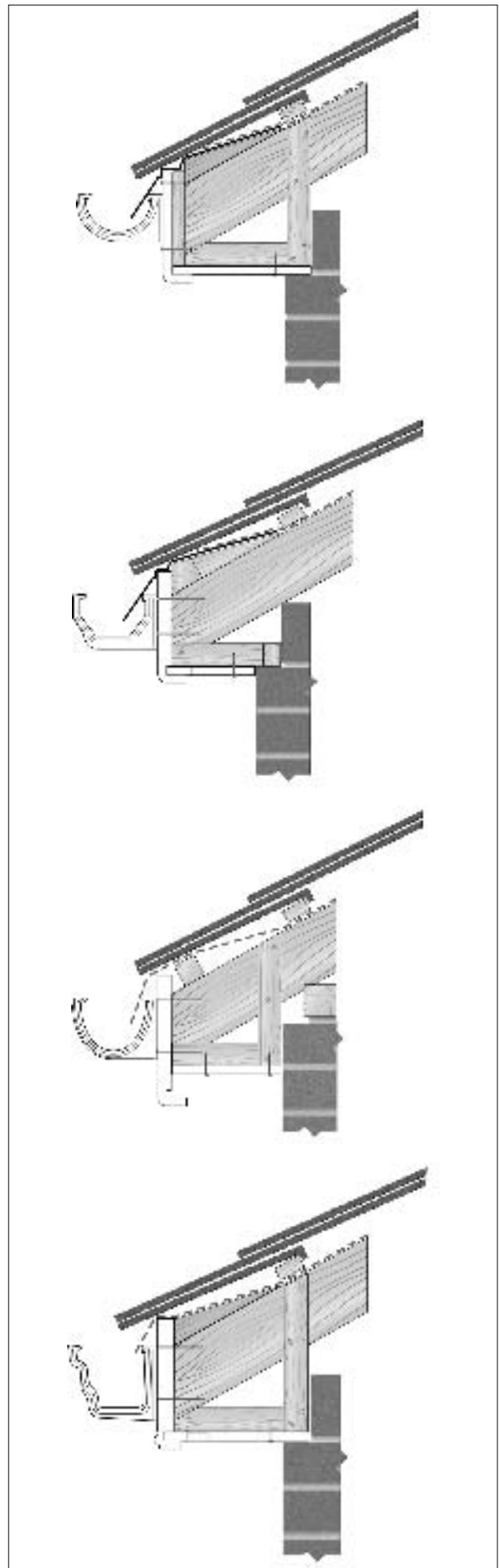

Fascias

14.6 Fascia boards are fixed to rafter feet using two specified ring-shanked nails at centres not exceeding 600 mm (65 mm long nails for Mammoth boards, 50 mm for other boards). Mammoth boards are fixed directly to rafter ends; other boards should be fixed to the rafter ends through a sound fascia backing board.

14.7 Butt joints between fascia boards should be made at the rafter end and covered with a butt joint trim, fixed to the end of one board with a suitable low modulus silicone sealant. Provision for expansion (minimum 10 mm between two 5 m boards) should be allowed between boards, both of which should be nailed to the rafter end.

14.8 At corners, the joint is covered with a corner trim fixed to the end of one board only with either a specified pin or low modulus silicone sealant. Provision for thermal movement of the boards should be allowed as detailed in section 14.7.

14.9 Gutter brackets are fixed through the fascia into supporting timberwork, normally the rafter feet.

Soffits

14.10 The board is cut to size and fitted into the groove at the rear of the fascia or sat on the top of the capping board at the rafter end.

14.11 The boards are fixed to rafter feet, soffit bearers, or other timber support at centres along their length, not exceeding 600 mm, and across their width, not exceeding 200 mm, using the specified 40 mm nails.

14.12 Where required, soffit boards may be joined along their length or width using a soffit jointing strip.

14.13 To comply with the Building Regulations a vented soffit board or soffit ventilator strip is used as required (see section 13.8).

Barge boards

14.14 Barge boards are installed by fixing fascia boards to a gable ladder or noggings, using the procedures given in sections 14.6 and 14.7.

14.15 Barge boards meeting at a ridge should be mitred to the appropriate angle.

14.16 Box ends are constructed from Universal board and trims to suit the roof pitch and overhead requirement. Any timber framework required in the construction of the box end must be preservative treated.

Technical Investigations

The following is a summary of the technical investigations carried out on the FloPlast White PVC-U Roof Trim System.

15 Tests

15.1 Tests were carried out on the Mammoth board to determine:

- dimensions
- voidage
- impact strength
- flexural strength.

15.2 An assessment was made of independent test data on the other products in the system relating to:

- weight per linear metre
- density
- dimensional stability
- resistance to impact
- resistance to impact at -10°C
- resistance to splitting and delamination (acetone)
- nail pull-through
- natural weathering
- accelerated weathering
- colour stability
- stress relief (heating)
- water absorption
- Vicat softening
- ash content
- surface spread of flame
- ignitability
- flammability
- fire propagation.

16 Other investigations

16.1 An assessment was made to establish the resistance of the product to wind action.

16.2 An assessment was made of the acceptability of soffit ventilators in meeting ventilation and NHBC requirements.

16.3 The manufacturing process, including the methods adopted for quality control, were assessed and details were obtained of the quality and composition of the materials used.

16.4 The practicability of the installation was assessed.

Bibliography

BS 476 *Fire tests on building materials and structures*
BS 476-7 : 1997 *Method of test to determine the classification of the surface spread of flame of products*

BS 4576 *Unplasticised polyvinyl chloride (PVC-U) rainwater goods and accessories*
BS 4576-1 : 1989(1998) *Half-round gutters and pipes of circular cross-section*

BS 5250 : 1989(1995) *Code of practice for control of condensation in buildings*

BS 5268 *Structural use of timber*

BS 5268-2 : 1996 *Code of practice for permissible stress design, materials and workmanship*

BS 5268-3 : 1998 *Code of practice for trussed rafter work*

Conditions of Certification

17 Conditions

17.1 This Certificate:

- (a) relates only to the product that is described, installed, used and maintained as set out in this Certificate;
- (b) is granted only to the company, firm or person identified on the front cover — no other company, firm or person may hold or claim any entitlement to this Certificate;
- (c) has to be read, considered and used as a whole document — it may be misleading and will be incomplete to be selective;
- (d) is copyright of the BBA.

17.2 References in this Certificate to any Act of Parliament, Regulation made thereunder, Directive or Regulation of the European Union, Statutory Instrument, Code of Practice, British Standard, manufacturers' instructions or similar publication, shall be construed as references to such publication in the form in which it was current at the date of this Certificate.

17.3 This Certificate will remain valid for an unlimited period provided that the product and the manufacture and/or fabricating process(es) thereof:

- (a) are maintained at or above the levels which have been assessed and found to be satisfactory by the BBA;
- (b) continue to be checked by the BBA or its agents; and
- (c) are reviewed by the BBA as and when it considers appropriate.

17.4 In granting this Certificate, the BBA makes no representation as to:

- (a) the presence or absence of any patent or similar rights subsisting in the product or any other product;
- (b) the right of the Certificate holder to market, supply, install or maintain the product; and
- (c) the nature of individual installations of the product, including methods and workmanship.

17.5 Any recommendations relating to the use or installation of this product which are contained or referred to in this Certificate are the minimum standards required to be met when the product is used. They do not purport in any way to restate the requirements of the Health & Safety at Work etc Act 1974, or of any other statutory, common law or other duty which may exist at the date of this Certificate or in the future; nor is conformity with such recommendations to be taken as satisfying the requirements of the 1974 Act or of any present or future statutory, common law or other duty of care. In granting this Certificate, the BBA does not accept responsibility to any person or body for any loss or damage, including personal injury, arising as a direct or indirect result of the installation and use of this product.



In the opinion of the British Board of Agrément, the FloPlast White PVC-U Roof Trim System is fit for its intended use provided it is installed, used and maintained as set out in this Certificate. Certificate No 00/3771 is accordingly awarded to FloPlast Limited.

On behalf of the British Board of Agrément

A handwritten signature in black ink, appearing to read 'P. C. Newson', is written over a light grey background.

Date of issue: 19th March 2001

Chief Executive