

Designated by Government
to issue
European Technical
Approvals

FLOPLAST AIR ADMITTANCE VALVES

Vanne d'adduction d'air
Luft Zulassung Ventil

Product



• THIS CERTIFICATE RELATES TO FLOPLAST AIR ADMITTANCE VALVES, COMPRISING 110 mm VALVES FOR PUSH-FIT AND SOLVENT WELDING, AND 82 mm, 50 mm, 40 mm AND 32 mm VALVES FOR SOLVENT WELDING.

- The valves are for use in above-ground drainage systems designed in accordance with this Certificate and have met the performance requirement of BS EN 12380 : 2002.
- The valves provide a means of ventilation to the drainage system to prevent the loss of water seals in traps and consequent release of foul air into the building.

continued

Regulations

1 The Building Regulations 2000 (as amended) (England and Wales)

 The Secretary of State has agreed with the British Board of Agrément the requirements of the Building Regulations to which air admittance valves can contribute in achieving compliance. In the opinion of the BBA, FloPlast Air Admittance Valves, used in accordance with the provisions of this Certificate, will meet or contribute to meeting the relevant requirements.

<p>Requirement: H1</p> <p>Comment:</p>	<p>Foul water drainage</p> <p>The valves will:</p> <ul style="list-style-type: none"> • provide adequate ventilation to prevent the loss of water seals in trapped appliances. See sections 7.1 to 7.4, 8.1 to 8.9, 9.1 and 9.2 of this Certificate • prevent foul air from entering the building. See section 9.1 of this Certificate • enable access to the sanitary pipe work for clearing blockages. See section 8.1 of this Certificate • contribute to the ventilation of underground drains. See sections 8.2 and 8.3 of this Certificate.
<p>Requirement: Regulation 7</p> <p>Comment:</p>	<p>Materials and workmanship</p> <p>The valves are acceptable. See section 11 and the <i>Installation</i> part of this Certificate.</p>

continued

- The drainage systems and the installation and use of the valves must be in accordance with the conditions set out in the Design Data and Installation parts of this Certificate.

2 The Building (Scotland) Regulations 2004 (as amended)



In the opinion of the BBA, FloPlast Air Admittance Valves, if used in accordance with this Certificate, will satisfy or contribute to satisfying the various Regulations and related Mandatory Standards as listed below.

<p>Regulation: 8(1)(2) Comment:</p>	<p>Fitness and durability of materials and workmanship The valves can contribute to a construction satisfying this Regulation. See sections 10 and 11 and the <i>Installation</i> part of this Certificate.</p>
<p>Regulation: 9 Standard: 3.7(b)(c) Comment:</p>	<p>Building standards – construction Wastewater drainage Sanitary pipe work incorporating the valves can satisfy the requirements of this Standard, with reference to clauses 3.7.1⁽¹⁾ and 3.7.7⁽¹⁾. See sections 7.1 to 7.4, 8.1 to 8.9, 9.1 and 9.2 of this Certificate. (1) Technical Handbook (Domestic).</p>

3 The Building Regulations (Northern Ireland) 2000 (as amended)



In the opinion of the BBA, FloPlast Air Admittance Valves, if used in accordance with the provisions of this Certificate, will satisfy or contribute to satisfying the various Building Regulations as listed below.

<p>Regulation: B2 Comment:</p>	<p>Fitness of materials and workmanship The valves are acceptable. See section 11 of this Certificate.</p>
<p>Regulation: B3(2) Comment:</p>	<p>Suitability of certain materials The valves are acceptable. See section 10 of this Certificate.</p>
<p>Regulation: N2 Comment:</p>	<p>Drainage systems The valves provide adequate ventilation to prevent the destruction of the water seals in traps. See sections 7.1 to 7.4, 8.1 to 8.9, 9.1 and 9.2 of this Certificate.</p>

4 Construction (Design and Management) Regulations 2007

Construction (Design and Management) Regulations (Northern Ireland) 2007

In the opinion of the BBA there is no information in this Certificate which relates to the obligations of the client, CDM co-ordinator, designer and contractors under these Regulations.

Technical Specification

5 Description

5.1 The FloPlast 110 mm push-fit valve, the 82 mm solvent-weld valve (see Figure 1) and the 110 mm solvent-weld valve (see Figure 2) are grey, white or black in colour and each comprise:

- valve body – PVC⁽¹⁾
- valve cover – PVC
- piston – ABS⁽²⁾
- piston seal – rubber
- cap seal – rubber
- finned seal⁽³⁾ – rubber

(1) Polyvinyl-chloride.

(2) Acrylonitrile-butadiene-styrene.

(3) Used with the 110 mm push-fit valve only.

5.2 The FloPlast 50 mm, 40 mm, and 32 mm valves (see Figure 3) are white or grey in colour⁽¹⁾ and each comprise:

- valve body – ABS
- valve cover – ABS
- piston – ABS
- adaptor⁽²⁾ – ABS

- piston seal – rubber
- cap seal – rubber.

(1) Black is available on request.

(2) Used with the 40 mm and 50 mm valve only.

5.3 The full product range is detailed in Table 1.

Table 1 Product range

Valve size ⁽¹⁾ (mm)	BS EN 12380 designation ⁽²⁾	Use
32	A1	see section 7.3
40	A1	see section 7.3
50	A1	see section 7.3
82	A1	see section 7.2
110	A1	see section 7.2
110 push-fit	A1	see section 7.2

(1) Nominal diameter of spigot.

(2) A1 = the valves are permitted to be used below flood level in locations where the temperature is within the range of –20°C to 60°C.

5.4 The valves are designed to fit waste pipes in accordance with the appropriate Standards including: BS EN 1329-1 : 2000, BS EN 1451-1 : 2000, BS EN 1455-1 : 2000, BS EN 1519-1 : 2000, BS EN 1565-1 : 2000, BS EN 1566-1 : 2000 and BS 4514 : 2001.

Figure 1 FloPlast 110 mm push-fit and 82 mm solvent-weld valve

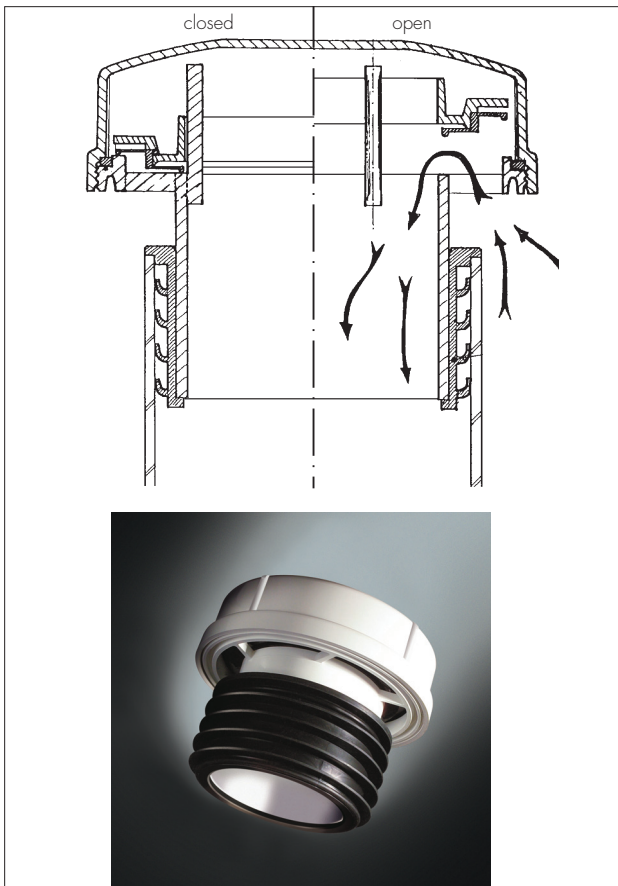

Figure 2 FloPlast 110 mm solvent-weld valve



5.5 The 110 mm push-fit valve, when used without the finned seal, becomes the 82 mm solvent-weld valve.

5.6 With the 110 mm valve, the diaphragm and cover seals are bought-in with each batch provided with a Certificate of Compliance to the agreed specification.

5.7 The reversal of the 50 mm adaptor allows the valve to be solvent welded into 40 mm waste pipe, and removal of the adaptor allows the valve to solvent welded to 32 mm waste pipe (see Figure 3). The piston and cap seals are bought-in with each batch provided with a Certificate of Compliance to the agreed specification.

5.8 The 110 mm and 82 mm valves are supplied protected (see section 6) to limit the risk of contamination or damage.

Figure 3 FloPlast 50 mm, 40 mm and 32 mm valves

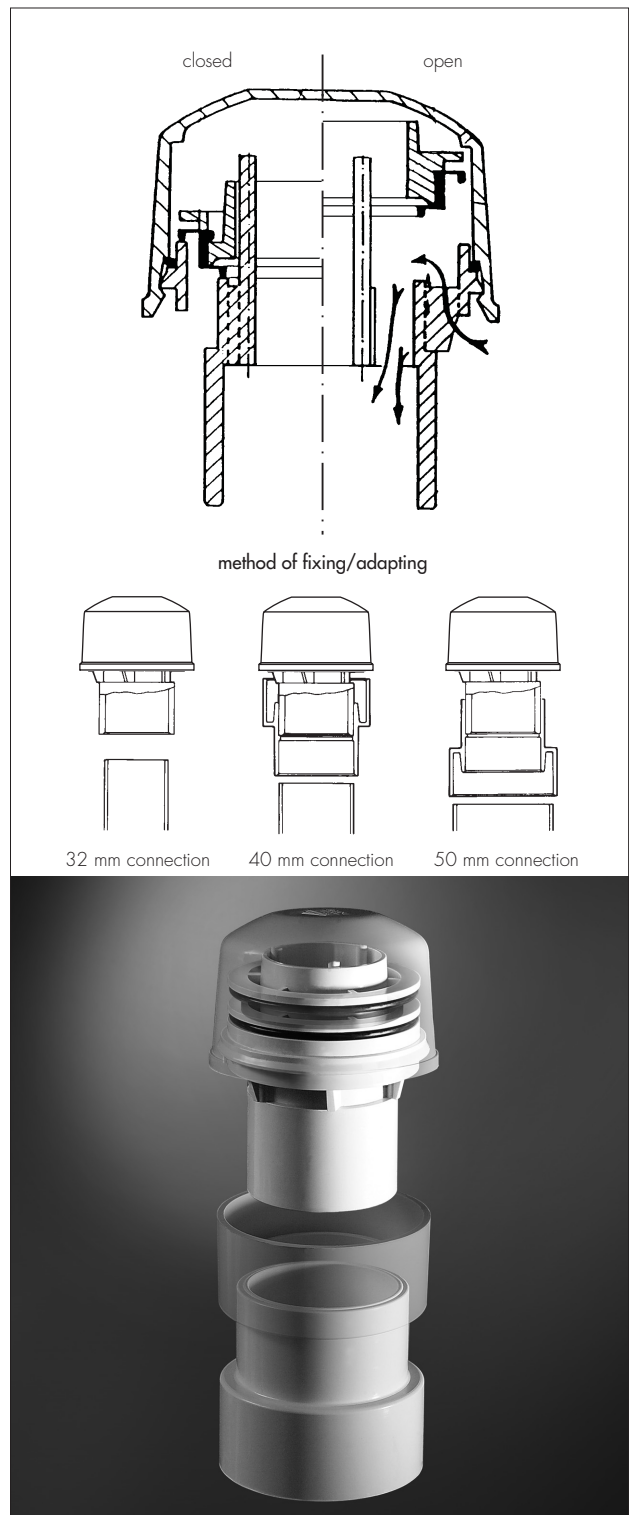

5.9 Continuous quality control is exercised during manufacture and assembly, including visual checks, checks on dimensional accuracy and airtightness. The raw materials and bought-in goods are subject to quality controls.

6 Delivery and site handling

The valves are individually sealed in plastic bags within a cardboard box to limit the risk of contamination and damage. They must be stored in an upright position within the boxes until required for use. The manufacturer's legend is moulded onto each valve cap.

7 General



7.1 When FloPlast Air Admittance Valves are used in above-ground drainage systems designed in accordance with BS 12056-1 : 2000 and BS 12056-2 : 2000 the valves will:

- admit air under conditions of reduced pressure in the discharge pipes and prevent water seals in traps from being drawn or evacuated
- prevent the release of foul air from the drainage system, and
- contribute to the ventilation of the main drain to which the discharge stack incorporating the valve is connected.

7.2 The 110 mm and 82 mm valves are for use on discharge stacks serving up to five storeys (see Figures 2 and 3).

7.3 The 50 mm, 40 mm and 32 mm valves are for use on branch discharge pipes.

7.4 The valves are for use in association with each other or separately.

8 Drainage system design



8.1 Drainage systems designed in accordance with BS EN 12056-1 : 2000 and BS EN 12056-2 : 2000 should be based on the airflow data given in Table 2⁽¹⁾. Typical installation details in accordance with BS EN 12056-1 : 2000 are given in Figures 4, 5 and 7.

(1) The Certificate holder's technical department provides an advisory service: Tel: 01795 431731 or e-mail: technical@floplast.co.uk — this is outside the scope of this Certificate.

Table 2 Airflow performance⁽¹⁾

Nominal size of pipe (mm)	Flow rate (litres per sec)
32	6.7
40	6.7
50	6.7
82	43.1
110	43.1

(1) These results are based on tests carried out in accordance with BS EN 12380 : 2002.

8.2 To contribute to the ventilation of the underground drain and to minimise the effects of excessive back pressures when a drain blockage occurs, the branch or main drain serving a stack or stacks fitted with the valves may require venting at a point upstream of the stack connection. For guidance the following should be noted (see Figure 6):

- for up to and including four dwellings, one, two, or three storeys in height, additional drain venting is not required. Where a drain serves more than four such dwellings equipped with the

valve, the drain should be vented according to the following rule, either by a conventional open-topped ventilating stack or discharge stack:

- 5 to 10 such dwellings — conventional ventilation to be provided at the head of the system
- 11 to 20 such dwellings — conventional ventilation to be provided at the mid-point and at the head of the system.
- for multi-storey domestic dwellings (other than those referred to above) and non-domestic buildings, conventional drain venting should be provided if more than one such building, each equipped with the valves, is connected to a common drain which itself is not vented by means of a ventilating stack or a discharge stack not fitted with a valve.

8.3 In installations other than those shown in Figure 6, stacks should not be fitted with the valves when the connecting drain is subject to periodic surcharging or is fitted with intercepting traps. An open-topped discharge stack or ventilating stack should be used in such cases.

8.4 The valve should be installed either within the building, preferably in a non-habitable space, such as a duct or roof, or externally to the building when protected from dust and insects and where it is easily accessible but not subject to interference, eg from vandals.

8.5 If the valve is to be installed in, or in close proximity to, a habitable space where noise of operation may cause a nuisance, consideration must be given to the use of a suitable form of sound insulation.

8.6 With the 110 mm and 82 mm valves the insulating cover should be used when there is a possibility of condensation forming and freezing within the valve body.

8.7 If self-siphonage may occur, a connection to the 32 mm valve is required within 300 mm of the trap (see Figure 7).

8.8 To prevent induced siphonage in a row of wash-basins, a 32 mm or 50 mm FloPlast valve should be fitted between the two wash-basins furthest from the discharge stack (see Figure 7).

8.9 Air admittance valves should not be used when the discharge stack provides the only ventilation to septic tanks or cesspools.

9 Effect on water seals



9.1 Under conditions of increased pressure in the drainage system, each valve will remain closed, thereby preventing the release of foul air into the building. In a correctly designed drainage system incorporating the valves in accordance with the recommendations given in this Certificate, increases in pressure will not be sufficient to cause traps in WCs or other appliances to become unsealed.

Figure 4 Typical domestic installation (eg bungalow or house)

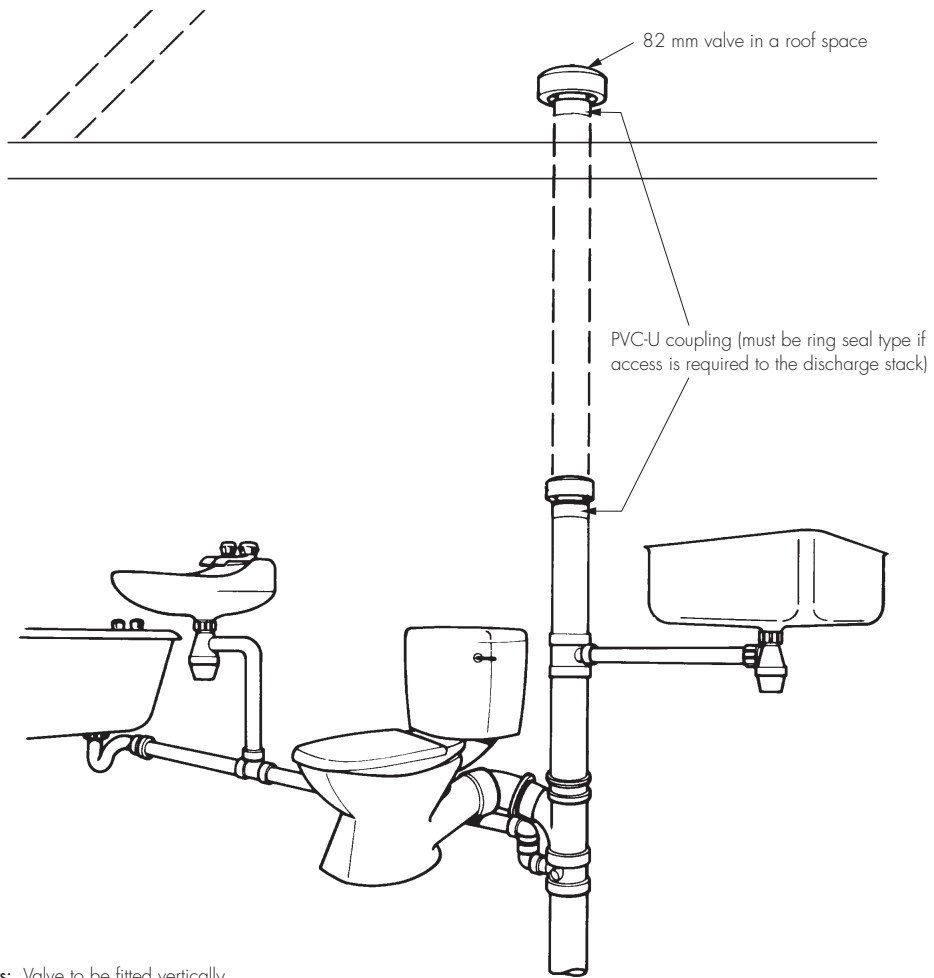

Notes: Valve to be fitted vertically.
If the valve is fitted inside a duct then the duct will require ventilation.
The size of branch discharge pipework and the location of appliances must be in accordance with BS EN 12056-2: 2000.

Figure 5 Domestic discharge system (eg multi-storey flats and halls of residence)

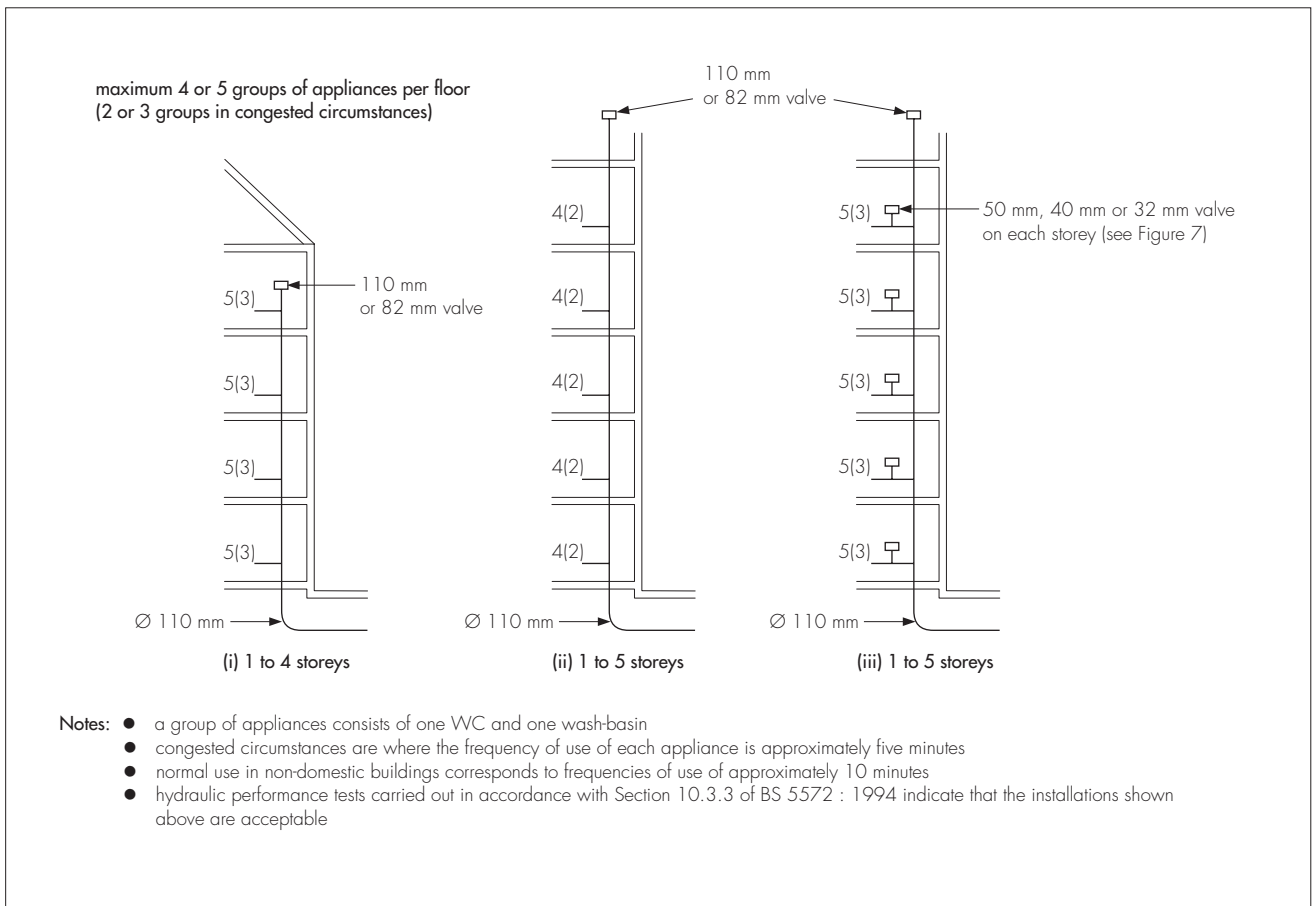

9.2 Should a pressure increase occur such that it is sufficient to cause the loss of water seals, it is an indication that a drain blockage has occurred or that the system is being overloaded or otherwise misused.

10 Maintenance

The valves do not require maintenance. In the event of damage they can be replaced easily. The 110 mm push-fit valves can be removed and the lids and poppets can be removed from the 110 mm and 82 mm solvent-weld valves to allow access for removal of blockages.

11 Durability



The valves are manufactured from conventional materials in drainage systems. Repeated opening and closing will not adversely affect the sealing or operation of the valve. When used in the context of this Certificate the product will not be subject to significant deterioration and will have a life equivalent to that of the drainage system in which it is installed.

Figure 7 Typical non-domestic (eg offices, factories, schools and other types of public buildings)

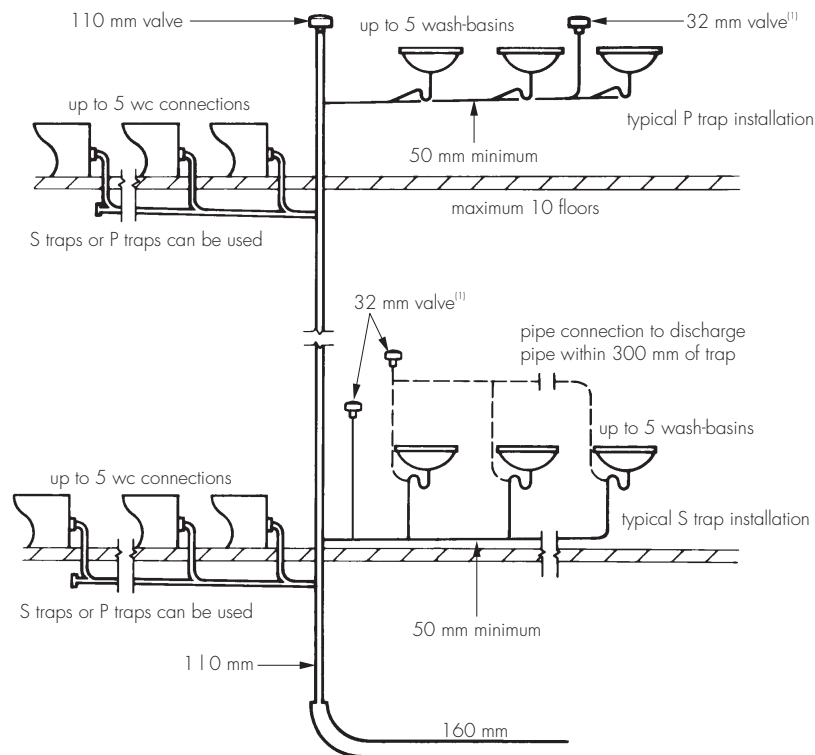

(1) The valve can be positioned below flood level (ie a level of which an appliance would overflow) in accordance with sections 8.7 and 8.8 of this Certificate.

Notes:

Valves to be fitted vertically.

If the valve is fitted inside a duct then the duct will require ventilation.

If access is required to the discharge stack then the valve must be fitted to a ring seal socket.

Branch discharge pipes to ranges of appliances must be designed in accordance with clause 7.2.3 of BS EN 12056-2 : 2000, where required branch pipe ventilation may be provided by the 50 mm FloPlast valve.

Installation

12 Procedure

12.1 Installation of FloPlast Air Admittance Valves must be carried out in accordance with the manufacturer's instructions. Joints are effected by conventional push-fit or solvent-weld joint methods.

12.2 Solvent-weld connections must be made using solvent cement to BS 6209 : 1982. This cement is suitable for solvent welding the valves to ABS and PVC-U fittings. Care must be taken in making solvent welded joints to prevent contact with the moving parts of the valve. Solvent welding

must not be used for connection to polypropylene or polyethylene pipes and fittings.

12.3 For 110 mm push-fit valves, a suitable lubricant recommended by the Certificate holder should be applied to the finned seal.

12.4 The valves must be fitted in a vertical position above the pipe being ventilated.

12.5 The valves are installed in discharge and/or ventilating pipes and obviate the need to penetrate the roof covering. Care should be taken to avoid contamination of the sealing surfaces, as this may affect airtightness.

Technical Investigations

The following is a summary of the technical investigations carried out on FloPlast Air Admittance Valves.

13 Tests

13.1 As part of the assessment resulting in the issue of the previous Certificate No 93/2916, tests were carried out to determine:

- dimensional accuracy
- airtightness when tested to a pressure of 40 mm and 200 mm water gauge
- airtightness at low positive pressure
- reduced pressure required to open the valve
- impact drop test and correct functioning
- effect of repeated operation.
- performance after oven-aging of connectors
- prevention of loss of trap seals due to induced and self-siphonage
- effect on trap seals when tested on four-storey test rig (110 mm/82 mm valve).

13.2 Tests were carried out on the 110 mm solvent-weld valve to establish:

- effect of pressure cycling
- airtightness under normal operating conditions
- performance in use on a stack when tested in accordance with BS 5572 : 1994
- practicability of installation
- dimensional checks
- Shore hardness of diaphragm seals.

13.3 Tests were conducted to determine the performance in use for the conditions covered in the *Design Data* part of this Certificate.

13.4 Tests were carried out on the full range of valves in accordance with BS EN 12380 : 2002:

- drop test
- airtightness test at 30 Pa, 500 Pa and 10000 Pa
- airtightness after endurance testing at -20°C and 60°C
- opening characteristics and airflow capacity
- effectiveness at temperatures below zero.

14 Investigations

14.1 The manufacturing process was examined including the methods adopted for quality control and details were obtained of the quality and composition of materials used.

14.2 A re-examination was made of the data on which the previous Certificates were based. The conclusions drawn from the original data remain valid.

14.3 An examination was made on data relating to:

- effect on trap seals when tested on five-storey test rigs
- self and induced siphonage
- stress relaxation
- practicability of installation
- airflow capacity
- creep
- durability.

14.4 Regular factory inspections have been carried out to ensure that quality is being maintained.

14.5 A user survey has been carried out to confirm performance in use.

Bibliography

BS 4514 : 2001 *Unplasticized PVC soil and ventilating pipes of 82.4 mm minimum mean, outside diameter and fittings and accessories of 82.4 mm and of other sizes — specification*

BS 5572 : 1994 *Code of practice for sanitary pipework*

BS 6209 : 1982 *Specification for solvent cement for non-pressure thermoplastics pipe systems*

BS EN 681-1 : 1996 *Elastomeric seals — Material requirements for pipe joint seals used in water and drainage applications — Vulcanized rubber*

BS EN 752-1 : 1996 *Drain and sewer systems outside buildings — Generalities and definitions*

BS EN 752-2 : 1997 *Drain and sewer systems outside buildings — Performance requirements*

BS EN 752-3 : 1997 *Drain and sewer systems outside buildings — Planning*

BS EN 752-4 : 1998 *Drain and sewer systems outside buildings — Hydraulic design and environmental considerations*

BS EN 1329-1 : 2000 *Plastics piping systems for soil and waste discharge (low and high temperature) within the building structure — Unplasticized poly(vinyl chloride) (PVC-U)*

BS EN 1451-1 : 2000 *Plastics piping systems for soil and waste discharge (low and high temperature) within the building structure — Polypropylene (PP) — Specifications for pipes, fittings and the system*

BS EN 1455-1 : 2000 *Plastics piping systems for soil and waste (low and high temperature) within the building structure — Acrylonitrile-butadiene-styrene (ABS) — Specifications for pipes, fittings and the system*

BS EN 1519-1 : 2000 *Plastics piping systems for soil and waste discharge (low and high temperature) within the building structure. Polyethylene (PE) — Specifications for pipes, fittings and the system*

BS EN 1565-1 : 2000 *Plastics piping systems for soil and waste discharge (low and high temperature) within the building structure — Styrene copolymer blends (SAN + PVC) — Specifications for pipes, fittings and the system*

BS EN 1566-1 : 2000 *Plastics piping systems for soil and waste discharge (low and high temperature) within the building structure — Chlorinated poly(vinylchloride) (PVC-C) — Specification for pipes, fittings and the system*

BS EN 12056-1 : 2000 *Gravity Drainage Systems inside Buildings — General and performance requirements*

BS EN 12056-2 : 2000 *Gravity Drainage Systems inside Buildings — Sanitary pipework, layout and calculation*

BS EN 12380 : 2002 *Air admittance valves for drainage systems — Requirements, test methods and evaluation of conformity*

Conditions of Certification

15 Conditions

15.1 This Certificate:

- relates only to the product/system that is named and described on the front page
- is granted only to the company, firm or person named on the front page — no other company, firm or person may hold or claim any entitlement to this Certificate
- is valid only within the UK
- has to be read, considered and used as a whole document — it may be misleading and will be incomplete to be selective
- is copyright of the BBA
- is subject to English law.

15.2 References in this Certificate to any Act of Parliament, Statutory Instrument, Directive or Regulation of the European Union, British, European or International Standard, Code of Practice, manufacturers' instructions or similar publication, are references to such publication in the form in which it was current at the date of this Certificate.

15.3 This Certificate will remain valid for an unlimited period provided that the product/system and the manufacture and/or fabrication including all related and relevant processes thereof:

- are maintained at or above the levels which have been assessed and found to be satisfactory by the BBA
- continue to be checked as and when deemed appropriate by the BBA under arrangements that it will determine
- are reviewed by the BBA as and when it considers appropriate.

15.4 In granting this Certificate, the BBA is not responsible for:

- the presence or absence of any patent, intellectual property or similar rights subsisting in the product/system or any other product/system
- the right of the Certificate holder to manufacture, supply, install, maintain or market the product/system
- individual installations of the product/system, including the nature, design, methods and workmanship of or related to the installation
- the actual works in which the product/system is installed, used and maintained, including the nature, design, methods and workmanship of such works.

15.5 Any information relating to the manufacture, supply, installation, use and maintenance of this product/system which is contained or referred to in this Certificate is the minimum required to be met when the product/system is manufactured, supplied, installed, used and maintained. It does not purport in any way to restate the requirements of the Health & Safety at Work etc Act 1974, or of any other statutory, common law or other duty which may exist at the date of this Certificate; nor is conformity with such information to be taken as satisfying the requirements of the 1974 Act or of any statutory, common law or other duty of care. In granting this Certificate, the BBA does not accept responsibility to any person or body for any loss or damage, including personal injury, arising as a direct or indirect result of the manufacture, supply, installation, use and maintenance of this product/system.



In the opinion of the British Board of Agrément, FloPlast Air Admittance Valves are fit for their intended use provided they are installed, used and maintained as set out in this Certificate. Certificate No 06/4343 is accordingly awarded to FloPlast Ltd.

On behalf of the British Board of Agrément

Date of issue: 31st March 2008

Head of Approvals
— Engineering

Chief Executive

