



Designated by Government  
to issue  
European Technical  
Approvals

### FAKRO ROOF TILE UNDERLAYS

Système de revêtement  
Dachbelagsystem

## Product



• THIS CERTIFICATE RELATES TO FAKRO ROOF TILE UNDERLAYS, FOR USE AS AN UNSUPPORTED OR FULLY SUPPORTED ROOF LINING MATERIAL FOR TILED OR SLATED PITCHED ROOFS.

- The product is for use in warm and ventilated cold pitched roof systems.
- The product prevents the ingress of wind-blown rain or snow.
- The membrane is resistant to tearing during installation and is flexible at low ambient temperatures.

These Front Sheets must be read in conjunction with the accompanying Detail Sheet which provides specific product information.

## Regulations — Detail Sheet 1

### 1 The Building Regulations 2000 (as amended) (England and Wales)

 The Secretary of State has agreed with the British Board of Agrément the aspects of performance to be used by the BBA in assessing the compliance of roof waterproofing with the Building Regulations. In the opinion of the BBA, Fakro Roof Tile Underlays, if used in accordance with the provisions of this Certificate, will meet or contribute to meeting the relevant requirements.

Requirement: C2(b)  
Comment:

Resistance to moisture  
Tests for weather resistance indicate that the product contributes towards a tiled or slated roof meeting this Requirement. See the *Weathertightness* section of these Front Sheets.

Requirement: Regulation 7  
Comment:

Materials and workmanship  
The product is an acceptable material. See the *Durability* section of these Front Sheets.

# Electronic Copy

## 2 The Building (Scotland) Regulations 2004



In the opinion of the BBA, Fakro Roof Tile Underlays, if used in accordance with the provisions of this Certificate, will satisfy or contribute to satisfying the various Regulations and related Mandatory Standards as listed below.

Regulation:	8	Fitness and durability of materials and workmanship
Regulation:	8(1)	Fitness and durability of materials and workmanship
Comment:		The product can contribute to a construction satisfying this Regulation. See the <i>Durability</i> section of these Front Sheets.
Regulation:	9	Building standards — construction
Standard:	3.10	Precipitation
Comment:		The product is an acceptable material. See clauses 3.10.1 <sup>(1)(2)</sup> and 3.10.7 <sup>(1)(2)</sup> of this Standard. See the <i>Weathertightness</i> section of these Front Sheets.
Regulation:	12	Building standards — conversions
Comment:		All comments given for this product under Regulation 9, also apply to this Regulation with reference to clause 0.12.1 <sup>(1)(2)</sup> and Schedule 6 <sup>(1)(2)</sup> .

(1) Technical Handbook (Domestic).  
(2) Technical Handbook (Non-Domestic).

## 3 The Building Regulations (Northern Ireland) 2000



In the opinion of the BBA, Fakro Roof Tile Underlays, if used in accordance with the provisions of this Certificate, will satisfy or contribute to satisfying the various Building Regulations as listed below.

Regulation:	B2	Fitness of materials and workmanship
Comment:		The product is an acceptable material. See the <i>Durability</i> section of these Front Sheets.
Regulation:	C4	Resistance to ground moisture and weather
Comment:		The product will contribute towards a roof satisfying this Regulation. See the <i>Weathertightness</i> section of these Front Sheets.

## 4 Construction (Design and Management) Regulations 1994 (as amended) Construction (Design and Management) Regulations (Northern Ireland) 1995 (as amended)

Information in this Certificate may assist the client, planning supervisor, designer and contractors to address their obligations under these Regulations.

See sections: 1 *Description* (1.2) of the accompanying Detail Sheet.

## Technical Specification

### 5 Delivery and site handling

5.1 Fakro Roof Tile Underlays are supplied in rolls and delivered to site individually wrapped in polythene. A technical leaflet bearing the product name is included with each roll and the BBA identification mark incorporating the number of this Certificate is shown on the leaflet.

5.2 Rolls should be stored flat or on end on a clean, level surface and kept under cover.

## Design Data

### 6 Weathertightness



6.1 Tests indicate that Fakro Roof Tile Underlays will resist the passage of water and wind-blown snow and dust into the interior of a building, under all conditions to be found in a roof constructed in accordance with the relevant clauses of BS 5534 : 2003.

6.2 The product resists penetration of liquid water to a head, and consequently may be used as

temporary waterproofing prior to the installation of slates or tiles. The period of such use should, however, be kept to a minimum.

### 7 Properties in relation to fire

7.1 The product has similar properties in relation to those of traditional polyethylene.

7.2 When the product is used in a fully supported situation, the reaction to fire will be determined by the support.

7.3 When used unsupported, there is a risk fire can spread if the material is accidentally ignited during maintenance works (eg roofer's or plumber's torch). As with all types of sarking material, care should be taken during building and maintenance to avoid the material becoming ignited.

### 8 Maintenance

Damage to the underlay can be repaired easily prior to the installation of slates or tiles by replacement of the damaged sheet or for limited areas, by patching and sealing correctly. Care should be taken to ensure that the weathertightness of the roof is maintained.

# Electronic Copy

## 9 Durability



The product will be virtually unaffected by the normal conditions found in a roof space and will have a life comparable with that of traditional roof tile underlays provided it is not exposed in sunlight for long periods (see section 6.5 of the accompanying Detail Sheet). Advice regarding exposure can be obtained from the Certificate holder.

## Bibliography

BS 5534 : 2003 *Code of practice for slating and tiling (including shingles)*

## Conditions of Certification

### 10 Conditions

10.1 This Certificate:

- (a) relates only to the product that is named, described, installed, used and maintained as set out in this Certificate;
- (b) is granted only to the company, firm or person identified on the front cover — no other company, firm or person may hold or claim any entitlement to this Certificate;
- (c) is valid only within the UK;
- (d) has to be read, considered and used as a whole document — it may be misleading and will be incomplete to be selective;
- (e) is copyright of the BBA;
- (f) is subject to English law.

10.2 References in this Certificate to any Act of Parliament, Regulation made thereunder, Directive or Regulation of the European Union, Statutory Instrument, Code of Practice, British Standard, manufacturers' instructions or similar publication, are references to such publication in the form in which it was current at the date of this Certificate.

10.3 This Certificate will remain valid for an unlimited period provided that the product and the manufacture and/or fabrication including all related and relevant processes thereof:

- (a) are maintained at or above the levels which have been assessed and found to be satisfactory by the BBA;
- (b) continue to be checked as and when deemed appropriate by the BBA under arrangements that it will determine; and
- (c) are reviewed by the BBA as and when it considers appropriate.

10.4 In granting this Certificate, the BBA is not responsible for:

- (a) the presence or absence of any patent, intellectual property or similar rights subsisting in the product or any other product;
- (b) the right of the Certificate holder to market, supply, install or maintain the product; and
- (c) the actual works in which the product is installed, used and maintained, including the nature, design, methods and workmanship of such works.

10.5 Any recommendations relating to the use or installation of this product which are contained or referred to in this Certificate are the minimum standards required to be met when the product is used. They do not purport in any way to restate the requirements of the Health & Safety at Work etc Act 1974, or of any other statutory, common law or other duty which may exist at the date of this Certificate or in the future; nor is conformity with such recommendations to be taken as satisfying the requirements of the 1974 Act or of any present or future statutory, common law or other duty of care. In granting this Certificate, the BBA does not accept responsibility to any person or body for any loss or damage, including personal injury, arising as a direct or indirect result of the installation and use of this product.



In the opinion of the British Board of Agrément, Fakro Roof Tile Underlays are fit for their intended use provided they are installed, used and maintained as set out in this Certificate. Certificate No 05/4292 is accordingly awarded to Fakro (GB) Ltd.

On behalf of the British Board of Agrément

Date of issue: 22nd December 2005

Chief Executive

# Electronic Copy

---

**British Board of Agrément**

P O Box No 195, Bucknalls Lane  
Garston, Watford, Herts WD25 9BA  
Fax: 01923 665301

©2005

e-mail: [mail@bba.star.co.uk](mailto:mail@bba.star.co.uk)  
website: [www.bbacerts.co.uk](http://www.bbacerts.co.uk)



For technical or additional information, contact the Certificate holder (see front page).  
For information about the Agrément Certificate, including validity and scope, tel: Hotline 01923 665400, or check the BBA website.



Fakro (GB) Ltd

Certificate No 05/4292

DETAIL SHEET 2

## EUROTOP N35 ROOF TILE UNDERLAY

## Product

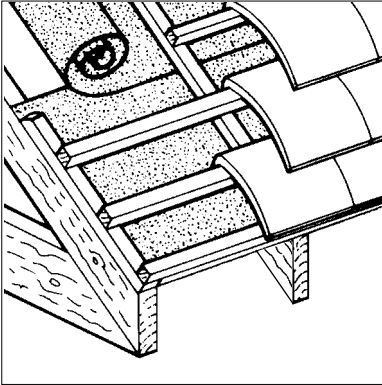

• THIS DETAIL SHEET RELATES TO EUROTOP N35 ROOF TILE UNDERLAY FOR USE IN WARM AND VENTILATED COLD PITCHED ROOF SYSTEMS.

*This Detail Sheet must be read in conjunction with the Front Sheets, which give the product's position regarding the Building Regulations, general information relating to the product, and the Conditions of Certification.*

## Technical Specification

**1 Description**

1.1 Eurotop N35 Roof Tile Underlay is manufactured by a lamination of a water vapour permeable film between two layers of non-woven polypropylene spun bond to form a flexible sheet for unsupported and fully supported specifications.

1.2 The product has the nominal characteristics of:

thickness (mm)	0.5
weight (gm <sup>2</sup> )	135
roll length (m)	50
roll width (m)	1.50
colour	green top surface white under surface

1.3 Quality control checks are carried out on the incoming materials, during production and on the finished product. Quality control checks on the finished product include:

- weight
- tensile strength and elongation
- head of water.

## Design Data

**2 General**

2.1 Eurotop N35 Roof Tile Underlay is satisfactory for use as a fully supported or unsupported underlay in tiled and slated pitched roofs constructed in accordance with the relevant clauses of BS 5534 : 2003.

2.2 The product is installed directly over insulation and secured using counter battens or, if draped over the counter battens, secured beneath the tiling battens.

**3 Strength**

The product will resist the loads associated with the installation of the roof.

**4 Wind loading**

4.1 Project design wind speeds should be determined, and wind uplift forces calculated, in accordance with BS 6399-2 : 1997.

4.2 Wind loading on the underlay should be calculated in accordance with BS 5534 : 2003, Section 5.5.2.7 (see the *Test* section of this Detail Sheet for acceptable wind loads with batten spacing for the draped product using a 25 mm tiling batten).

4.3 When fully supported on timber sarking with counter battens, the product has adequate resistance to wind uplift forces.

## 5 Risk of condensation

5.1 For design purposes, the underlay's resistance to water vapour transmission may be taken as not more than  $0.2 \text{ MNsg}^1$ . For roofs designed in accordance with BS 5534 : 2003, it may be regarded as a type LR' membrane.

5.2 In common with all roofs, care must be taken in the overall design and installation to minimise the risk of water vapour coming into contact with cold parts of the construction. Factors to be considered and minimised include moisture diffusion through the ceiling, infiltration through unsealed openings/ penetrations in the ceiling and services evaporating or venting moisture into cold spaces.

### Ceiling and insulation horizontal (cold roof)

5.3 Roofs designed and constructed in accordance with BS 5250 : 2002 will adequately limit the risk of interstitial condensation.

### Ceiling and insulation inclined (warm roof)

5.4 For roofs with an insulated inclined ceiling, ventilation above or below the underlay will not be required provided that the passage of moisture by diffusion and by convection is controlled, eg, by a vapour control layer or a continuous envelope of insulation with a high vapour resistance.

### Ceiling and insulation partially inclined (warm roof and cold roof)

5.5 Where an insulated ceiling only spans part of the roofline, resulting cold roof spaces should be ventilated in accordance with BS 5250 : 2002, Section 8.4.2.5 and 8.4.2.6.

## Installation

### 6 Procedure

#### General

6.1 Eurotop N35 Roof Tile Underlay must be installed and fixed in accordance with the

manufacturer's instructions and the relevant recommendations of BS 5534 : 2003 and BS 8000-6 : 1990. Installation can be carried out under all conditions normal to roofing work.

6.2 The product is installed with the coloured or printed side uppermost and lapped to shed water down the slope.

6.3 Overlaps must be provided with the minimum dimensions given in Table 1.

Table 1 Minimum overlaps

Roof pitch (°)	Horizontal lap (mm)		Vertical lap (mm)
	Fully supported	Not Fully supported	
12.5 to 14	150	225	100
15 to 34	100	150	100
35+	75	100	100

6.4 Hips and valleys should be covered with a 600 mm wide strip of Eurotop N35.

6.5 In closed eaves constructions, the use of eaves guards is recommended.

#### Fully supported

6.6 The product may be used over sarking boards of softwood, C4 grade chipboard, water-resistant grade plywood or water-resistant grade OSB, and either continuous insulation or insulation placed between the rafters.

6.7 The product is secured to the support with counter battens at least 12 mm thick to create an air space between the product and the tiles for drainage and vapour dispersal. The counter battens are fixed with corrosion-resistant staples or galvanized clout nails as appropriate. Tiling battens are secured to the counter battens and support with appropriate fixings.

6.8 Care must be taken to minimise the risk of interstitial condensation as described in section 5.4, particularly for timber sarking which may be below the dew-point for extended periods during winter months.

#### Unsupported

6.9 The product, when installed as an unsupported system, is fixed in the traditional method for roof tile underlays, ie draped between the rafters.

## Technical Investigations

The following is a summary of the technical investigations carried out on Eurotop N35 Roof Tile Underlay.

### 7 Tests

Samples of Eurotop N35 Roof Tile Underlay were obtained from the company for testing. The result of the tests carried out by, or on behalf of, the BBA, which show typical results for the material, are summarised in Tables 2 to 4.

**Table 2** Physical properties

Test (units)	Method <sup>(1)</sup>	Mean result
Mullen burst strength (kNm <sup>2</sup> )	BS 3137	524
Head of water (mm)	BS EN 20811	5540

(1) The test documents are detailed in the *Bibliography*. Numbers in the table refer to sections/parts of the various documents.

**Table 3** Physical properties — directional

Test (units)	Method <sup>(1)</sup>	Mean result
Tensile strength (N per 50 mm) unaged	EN 12311-1	
long <sup>(2)</sup>		274
trans <sup>(3)</sup>		168
UVA/heat ageing <sup>(4)</sup>		
long <sup>(2)</sup>		209
trans <sup>(3)</sup>		139
Wet strength <sup>(5)</sup>		
long <sup>(2)</sup>		288
trans <sup>(3)</sup>		177
Elongation at break (%) unaged	EN 12311-1	
long <sup>(2)</sup>		44
trans <sup>(3)</sup>		69
UVA/heat ageing <sup>(4)</sup>		
long <sup>(2)</sup>		24
trans <sup>(3)</sup>		52
wet strength <sup>(5)</sup>		
long <sup>(2)</sup>		44
trans <sup>(3)</sup>		69
Tear resistance (nail) (N) unaged	BS EN 12310-1	
long <sup>(2)</sup>		121
trans <sup>(3)</sup>		123

(1) The test documents are detailed in the *Bibliography*. Numbers in the table refer to sections/parts of the various documents.

(2) Longitudinal direction.

(3) Transverse direction.

(4) UV/heat aged at 50°C UVA/heat ageing for 90 days at 70°C ± 2.

(5) Wet strength soak at 23°C for 24 h — tested surface wet.

**Table 4** Service performance

Test (units)	Method <sup>(1)</sup>	Mean result
Water vapour permeability at 25°C/75% RH (gm <sup>2</sup> day <sup>-1</sup> )	BS 3177	1527
Vapour resistance (MNsg <sup>-1</sup> )	BS 3177	0.14
Dimensional stability	BS EN 1107-2	
long <sup>(2)</sup>		1.43
trans <sup>(3)</sup>		+0.35
Slip resistance (coefficient of friction)	T1/10 <sup>(4)</sup>	
dry		0.75
wet		0.56
Resistance to water penetration	EN 1928	
unaged		pass
UV heat aged <sup>(5)</sup>		pass
Resistance to streaming water	MOAT 69 : 4.2.2	
unsupported		pass
supported		pass
Resistance to wind loads	MOAT 69 : 4.2.1	
batten spacing 350 mm		0.5 <sup>(6)</sup>
batten spacing 330 mm		1.0 <sup>(6)</sup>
batten spacing 300 mm		1.0 <sup>(6)</sup>
batten spacing 250 mm		2.5 <sup>(6)</sup>

(1) The test documents are detailed in the *Bibliography*. Numbers in the table refer to sections/parts of the various documents.

(2) Longitudinal direction.

(3) Transverse direction.

(4) BBA Test Method.

(5) UV/heat aged at 50°C UVA/heat ageing for 90°C at 70°C ± 2.

(6) Maximum pressure achieved.

### 8 Investigations

8.1 The manufacturing process was assessed, including the method adopted for quality control, and details were obtained of the quality and composition of the materials used.

8.2 Test data on the condensation risk in warm roof constructions, and specifically those containing sarking boards, incorporating Eurotop N35 Roof Tile Underlay were examined.

## Bibliography

BS 3137 : 1972 *Methods for determining the bursting strength of paper and board*

BS 3177 : 1959 *Method for determining the permeability to water vapour of flexible sheet materials used for packaging*

BS 5250 : 2002 *Code of practice for control of condensation in buildings*

BS 5534 : 2003 *Code of practice for slating and tiling (including shingles)*

BS 6399-2 : 1997 *Loading for buildings — Code of practice for wind loads*

BS 8000-6 : 1990 *Workmanship on building sites — Code of practice for slating and tiling of roofs and claddings*

BS EN 1107-2 : 2001 *Flexible sheets for waterproofing — Determination of dimension stability — Plastic and rubber sheets for roof waterproofing*

BS EN 12310-1 : 2000 *Flexible sheets for waterproofing — Determination of resistance to tearing (nail shank) — Part 1 — Bitumen sheets for roof waterproofing*

BS EN 20811 : 1992 *Textiles. Determination of resistance to water penetration. Hydrostatic pressure test*

EN 1928 : 2000 *Flexible sheets for waterproofing — Bitumen, plastic and rubber sheets for roof waterproofing — Determination of watertightness*

EN 12311-1 : 2000 *Flexible sheets for waterproofing — Determination of tensile properties — Part 1 — Bitumen sheets for roof waterproofing*

MOAT No 69 : 2004 *UEAtc Technical Report for the Assessment of Discontinuous Roofing Underlay Systems*



On behalf of the British Board of Agrément

A handwritten signature in black ink, appearing to read 'G. A. Cooper'.

Date of issue: 22nd December 2005

Chief Executive