

Delta Membrane Systems Ltd

Unit 7
Bassett Business Centre
Hurricane Way
North Weald, Epping
Essex CM16 6AA

Tel: 01992 523811 Fax: 01992 524046
e-mail: info@deltamembranes.com
website: www.deltamembranes.com



Agrément Certificate
00/3742
Product Sheet 1

DELTA MEMBRANE SYSTEMS

DELTA-MS500

PRODUCT SCOPE AND SUMMARY OF CERTIFICATE

This Certificate relates to Delta-MS500, a moulded HDPE membrane for damp-proofing walls, floors and vaulted ceilings in new construction or existing buildings. It can be used above or below ground, over a contaminated or damp background, to support a dry lining and flooring.

AGRÉMENT CERTIFICATION INCLUDES:

- factors relating to compliance with Building Regulations where applicable
- factors relating to additional non-regulatory information where applicable
- independently verified technical specification
- assessment criteria and technical investigations
- design considerations
- installation guidance
- regular surveillance of production
- formal three-yearly review.



KEY FACTORS ASSESSED

Resistance to water and water vapour — the membrane is water resistant and has a high resistance to water vapour transmission (see section 5).

Resistance to salt transfer — the membrane provides an effective barrier to the transmission of salts or other contaminants from the substrate (see section 7).

Resistance to puncture, impact and loading — the membrane has a high resistance to puncture and will not be damaged by normal foot traffic during installation, or while laying concrete, or screeding. It can support the long-term loadings likely to be experienced in service without undue deformation (see section 8).

Durability — under normal conditions of use the system will provide an effective barrier to the transmission of salts, liquid water and water vapour for the life of the structure in which it is incorporated (see section 11).

The BBA has awarded this Agrément Certificate to the company named above for the product described herein. The product has been assessed by the BBA as being fit for its intended use provided it is installed, used and maintained as set out in this Certificate.

On behalf of the British Board of Agrément

A handwritten signature in black ink, appearing to read 'Simon Wroe'.

Simon Wroe
Head of Approvals — Materials

A handwritten signature in black ink, appearing to read 'Greg Cooper'.

Greg Cooper
Chief Executive

Date of Third issue: 2 July 2010

Originally certificated on 24 November 2000

The BBA is a UKAS accredited certification body — Number 113. The schedule of the current scope of accreditation for product certification is available in pdf format via the UKAS link on the BBA website at www.bbacerts.co.uk

Readers are advised to check the validity and latest issue number of this Agrément Certificate by either referring to the BBA website or contacting the BBA direct.

British Board of Agrément
Bucknalls Lane
Garston, Watford
Herts WD25 9BA

tel: 01923 665300
fax: 01923 665301
e-mail: mail@bba.star.co.uk
website: www.bbacerts.co.uk

©2010

Regulations

In the opinion of the BBA, Delta-MS500, if used in accordance with the provisions of this Certificate, will meet or contribute to meeting the relevant requirements of the following Building Regulations:



The Building Regulations 2000 (as amended) (England and Wales)

For new construction and a 'Material Change of Use' of an existing building, as defined in Regulation 5a

Requirement:	C2(a)(b)	Resistance to moisture
Comment:		The system adequately resists the passage of moisture. See section 5.1 of this Certificate.
Requirement:	Regulation 7	Materials and workmanship
Comment:		The system is acceptable. See section 11 and the <i>Installation</i> part of this Certificate.



The Building (Scotland) Regulations 2004 (as amended)

For new construction and a 'Conversion' of an existing building, as defined in Regulation 4

Regulation:	8(1)	Fitness and durability of materials and workmanship
Comment:		The system is acceptable. See section 11 and the <i>Installation</i> part of this Certificate.
Regulation:	9	Building standards — construction
Standard:	3.3	Flooding and ground water
Comment:		The system can contribute to minimising or eliminating the effects of flooding on the building fabric and/or the building element, with reference to clause 3.3.1 ⁽¹⁾⁽²⁾ . See section 5.1 of this Certificate.
Standard:	3.4	Moisture from the ground
Comment:		The system adequately resists the passage of moisture, with reference to clauses 3.4.1 ⁽¹⁾⁽²⁾ , 3.4.2 ⁽¹⁾⁽²⁾ , 3.4.5 ⁽¹⁾⁽²⁾ , 3.4.6 ⁽¹⁾⁽²⁾ and 3.4.7 ⁽¹⁾⁽²⁾ . See section 5.1 of this Certificate.
Standard:	3.6(a)	Surface water drainage
Comment:		The system can contribute to satisfying this Standard, with reference to clause 3.6.3 ⁽¹⁾⁽²⁾ . See section 5.1 of this Certificate.
Standard:	3.10	Precipitation
Comment:		The system adequately resists the passage of moisture, with reference to clause 3.10.1 ⁽¹⁾⁽²⁾ . See section 5.1 of this Certificate.
Regulation:	12	Building standards — conversions
Comment:		All comments given for this system under Regulation 9, also apply to this Regulation, with reference to clause 0.12.1 ⁽¹⁾⁽²⁾ and Schedule 6 ⁽¹⁾⁽²⁾ . (1) Technical Handbook (Domestic). (2) Technical Handbook (Non-Domestic).



The Building Regulations (Northern Ireland) 2000 (as amended)

For new construction and a 'Material Change of Use' of an existing building, as defined in Regulation A9

Regulation:	B2	Fitness of materials and workmanship
Comment:		The system is acceptable. See section 11 and the <i>Installation</i> part of this Certificate.
Regulation:	C4(a)(b)	Resistance to ground moisture and weather
Comment:		The system adequately resists the passage of moisture. See section 5.1 of this Certificate.

Construction (Design and Management) Regulations 2007

Construction (Design and Management) Regulations (Northern Ireland) 2007

Information in this Certificate may assist the client, CDM co-ordinator, designer and contractors to address their obligations under these Regulations.

See section: 1 *Description* (1.2) of this Certificate.

Non-regulatory Information

NHBC Standards 2008

NHBC accepts the use of Delta-MS500, when installed and used in accordance with this Certificate, in relation to *NHBC Standards*, Chapter 5.1 *Substructure and ground bearing floors* and 5.2 *Suspended ground floors*.

1 Description

1.1 Delta-MS500 membrane is a translucent, high-density polyethylene (HDPE) sheet with moulded studs, for use as a damp-proofing membrane. The membrane is available in the following dimensions:

Thickness (mm)	0.6
Stud height (mm)	8
Weight per unit area ($\text{kg}\cdot\text{m}^{-2}$)	0.5
Roll length (m)	20.0
Roll width (m) ⁽¹⁾	2.0 and 2.4
Weight per roll (kg)	22 and 26
Air gap volume ($\text{l}\cdot\text{m}^{-2}$)	5.3

(1) Includes a 70 mm flanged stud-free area for overlapping sheets.

1.2 The membrane is formed in a continuous process in which HDPE is extruded into sheets and the studs impression formed.

1.3 Quality control is exercised over raw materials, during manufacture and on the final product.

1.4 Ancillary items used with the membrane include:

- Delta Qwik-Seal Plug — a plastic plug supplied with preformed rubber seal for use in masonry walls and concrete (see Figure 1)
- Delta Plug — glass-filled nylon plug for use in masonry walls and concrete (see Figure 2)
- Delta Tape — black butyl tape for sealing joints in the membrane
- Delta Rope — black butyl beading for sealing the membrane around pipes and openings, joining floor and wall membranes, and to seal around the head of the Delta Plugs prior to fixing the membrane
- Delta Mastic — an acrylic sealant for sealing the membrane around pipes and openings
- Delta Corner Strip — a self-adhesive membrane strip for sealing junctions between walls and floors, and for sealing joints at corners
- Delta Primer — a solvent-based primer for sealing porous substrates prior to application of the Delta range of butyl-based sealing products.

Figure 1 Delta Qwik-Seal Plug fixing detail

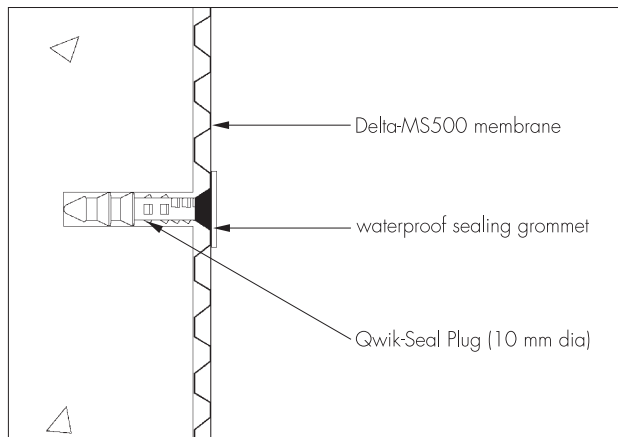
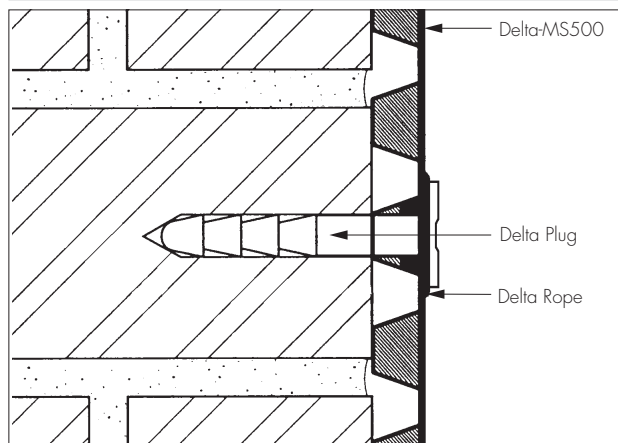

Figure 2 Delta Plug fixing detail



2 Delivery and site handling

2.1 The membrane is delivered to site in rolls secured with outer wrapping, and a headband bearing the product and manufacturer's name.

2.2 Rolls should be stored on end, under cover and protected from sharp objects, sunlight and high temperatures.

2.3 The packaging details of the ancillary items are shown in Table 1.

Item	Dimensions/volume	Packaging/quantity
Delta Qwik-Seal Plug	10 mm diameter 58 mm long	Boxes of 100
Delta Plug	11 mm diameter 70 mm long	Boxes of 100 or 1000
Delta Tape	22.5 m long 28 mm wide 2 mm thick	1 roll per box 10 rolls per outer box
Delta Rope	4.75 m long 10 mm diameter	1 roll per box 10 rolls per outer box
Delta Mastic	0.4 litre cartridge	24 cartridges per box
Delta Corner Strip	20 m long 150 mm wide	Single rolls 4 rolls per box
Delta Primer	5 litre	Single 5 litre tin

2.4 Delta Primer is classified as 'harmful' and 'flammable' under *The Chemicals (Hazard Information and Packaging for Supply) Regulations 2009* (CHIP4) and should be stored in a cool place away from naked flames.

Assessment and Technical Investigations

The following is a summary of the assessment and technical investigations carried out on Delta-MS500.

Design Considerations

3 Use

3.1 Delta-MS500 is used as damp-proofing on walls, floors and vaulted ceilings, above and below ground, in new construction or in existing buildings over a contaminated or damp background. It can support a dry lining, screed or flooring, in the following situations:

- on damp walls and floors in underground situations subject to high groundwater levels, and perennial moisture
- on vaulted ceilings of archways or cellars subject to water ingress
- in conjunction with a remedial dpc system where the walls and floors have a high salt content, and/or it is necessary to complete the installation immediately without allowing a period for initial drying
- over walls and floors which have a friable or painted surface, are contaminated (eg with oil or mould), or have a high salt content
- as a waterproofing membrane in areas subject to vibration.

3.2 Depending on the application required and the site conditions, the membrane may be used as:

- an underfloor damp-proof membrane
- a dry lining for walls, ventilated into the room via aeration slots at the top and bottom of the wall or via passive air vents, where access through an external wall is available
- a sealed system covering wall, floor and ceiling with provision made for disposing of water build-up behind the membrane via a sump and pump.

3.3 The membrane has not been assessed for use in chemically contaminated areas, such as brownfield sites.

3.4 The membrane consists of 0.6 mm thick HDPE and, in the opinion of the BBA, meets the requirement for a radon barrier according to BRE Report (BR 211 : 1999) *Radon : guidance on protective measures for new dwellings*. However, the effectiveness of the joint sealing system used with Delta-MS500 has not been assessed against radon by the BBA and is outside the scope of this Certificate.

3.5 The system is satisfactory for use in Type C (drained protection) constructions in accordance with BS 8102 : 2009.

3.6 Under normal operating conditions the membrane is not affected by underfloor heating.

4 Practicability of installation

The membrane should only be installed by installers who have been trained and approved by the Certificate holder, or by competent specialist contractors.

5 Resistance to water and water vapour

 5.1 The membrane is water resistant and has a high resistance to water vapour transmission. However, the system as installed is not resistant to hydrostatic pressure and, consequently, the measures described in the *Installation* part of this Certificate must be followed to ensure that the membrane acts as a drainage layer with no excessive build-up of water behind the system.

5.2 All joints and fixings must be sealed with Delta sealing products, and drainage channels and gullies, or sumps and pumps should be installed as necessary to disperse excess or standing water.

6 Risk of condensation

6.1 As with any room, there is a need to control the generation and dispersal of moisture in the internal environment and to select appropriate and robust designs to minimise the risk of both surface and interstitial condensation, especially where insulation is used over the membrane.

6.2 In common with most waterproofing membranes, the product has a very high resistance to vapour diffusion, and when placed on the cold side of a construction may increase the risk of interstitial condensation. A calculation should be carried out to BS 5250 : 2002 and designers should consider appropriate techniques for managing the safe egress of moisture vapour with care (such as control of the internal room environment or use of a vapour control layer on the warm side of the insulation), and in particular the effect of moisture on any materials at or in contact with materials below the local dew-point.

7 Resistance to salt transfer

The membrane provides an effective barrier to the transmission of salts or other contaminants from the substrate.

8 Resistance to puncture, impact and loading

8.1 The membrane has a high resistance to puncture and will not be damaged by normal foot traffic during installation or while laying concrete or screeding to BS 8204-1 : 2003.

8.2 The membrane can support the long-term imposed loadings defined in NA to BS EN 1991-1-1 : 2002, Table NA.2, categories A to D, without undue deformation.

9 Wall-mounted fittings

Wall-mounted fittings (apart from lightweight items such as framed pictures) should be fixed where possible into battens, whose position and number of support fixings into the loadbearing structure are predetermined. Only in exceptional circumstances should fittings be fixed (using proprietary fixings) through the membrane and lining board to the loadbearing structure behind. Holes made in the membrane must be repaired in accordance with the Certificate holder's recommended procedures.

10 Maintenance

10.1 As the membrane is confined within a wall or floor space and has suitable durability (see section 11), maintenance is not required.

10.2 Regular maintenance of all gullies, sumps and pumps must be conducted to ensure that a build-up of water does not occur behind the membrane.

11 Durability

 Under normal conditions of use the system will provide an effective barrier to the transmission of salts, liquid water and water vapour for the life of the structure in which it is incorporated.

Installation

12 Survey

12.1 Where the property is below ground, or where conditions are damp, a full survey is necessary by a specialist waterproofing surveyor to diagnose the cause and to establish if treatment is required.

12.2 If rising damp to above-ground elevations is found, a remedial treatment is conducted in accordance with the relevant Agrément Certificate, BS 6576 : 2005 and the Property Care Association *Code of Practice for Installation of Remedial Damp-proof Courses in Masonry Walls*.

12.3 Appropriate remedial measures are taken to rectify major causes of damp conditions or water ingress, and to repair structural defects.

13 Surface preparation

13.1 When used in new constructions, the concrete base must be laid in accordance with BS 8204-1 : 2003.

13.2 If a board covering is to be laid directly on the membrane, the concrete base must have a surface regularity with a maximum permissible departure of 5 mm from the underside of a 2 m straight edge, resting in contact with the floor, in accordance with BS 8204-1 : 2003.

13.3 When used in existing buildings any unsound plaster, render or screed is removed to expose the substrate and cleaned with a stiff brush to remove loose material, laitance, salt residue, mould or adhesive. If mould is present the substrate is treated with a fungicidal wash.

13.4 Uneven floor substrates should be dubbed out with a cement-sand (1:4) or cement-lime-sand (1:1:6) render or screed, to the tolerance described in section 13.2. They should be allowed to dry thoroughly before the Delta-MS500 membrane is installed above.

14 Procedure

General

14.1 Delta-MS500 may be used in combination with any of the appropriate Delta membranes which are the subject of other Product Sheets of this Certificate.

14.2 The membrane should be used with the flanged edge positioned in front of and overlapping the previously installed membrane width. Joints with the flanged edge are sealed using Delta Tape, while stud-to-stud joints (without the flanged edge) are sealed by overlapping the membrane by a minimum of three studs and positioning Delta Rope between the last two rows of studs. Alternatively, the stud-to-stud joint can be oversealed using Delta Corner Strip.

14.3 Fixings are made through the membrane into 10 mm holes, drilled centrally through the studs. Delta Qwik-Seal Plugs (complete with preformed rubber seal) are inserted into the holes and hammered flush with the membrane with a club hammer. The seal must be compressed to function as a barrier against water ingress, and this should be visually checked as each plug is fixed.

14.4 Alternatively, fixings are made through 11 mm holes, drilled centrally through the studs. Delta Plugs, to which Delta Rope has been applied around the rim, are inserted into the holes and hammered flush with the membrane. The Delta Rope forms a sealing gasket between the plug and the membrane.

14.5 On difficult substrates, the use of the translucent membrane allows the contractor to view the substrate through the membrane and choose the optimum site for each fixing.

14.6 On walls and ceilings, preservative-treated timber battens of minimum dimensions 25 mm by 38 mm are fixed into the Delta Plug's fixing hole using No 12 screws, or Delta Qwik-Seal Plug's fixing hole using No 10 screws, with a maximum screwing-in depth of 30 mm. The membrane can also be dry-lined, using free-standing framework, blockwork or similar. Where necessary, these should be tied back by fixing into the Delta Plug sealed with Delta Rope, or the Delta Qwik-Seal Plug.

Walls

14.7 Installation of the membrane is usually commenced at the top of the construction. The membrane may require initial fixing on a ceiling or along the upper edge of a wall, prior to final fixings along batten runs. For joints where the flanged edge is not used, the two membrane sheets are overlapped by a minimum of 100 mm, and for horizontal joints the lower sheet is always positioned in front of the upper sheet.

14.8 Spacing between fixings will depend on the method of dry lining to be applied. When using preservative-treated timber battens the fixings should be spaced at 600 mm centres. Proprietary metal fast track systems and independent frame systems will require less fixings, but sufficient should be used to ensure that the membrane is reasonably tight to the wall, especially at corners

14.9 The installation is conducted over windows and the membrane is cut away to expose them. The gaps are then sealed with Delta Tape, Delta Rope or Delta Corner Strip.

14.10 For doors and some obstructions the technique covered in section 14.9 cannot be used. Instead, the membrane is installed up to the perimeter and the gap sealed in the same manner.

14.11 Power cables, points and light switches should preferably be remounted in front of the membrane.

14.12 In below-ground installations, the practice of leaving the top of the wall membrane unsealed where there is no requirement for a ceiling membrane to be installed may need to be reconsidered in cases where ingress of gases, odours, or vermin is a consideration (such as in proximity to food preparation areas). The advice of the Certificate holder should be sought in these situations.

14.13 In above-ground installations the build up of water vapour behind the membrane is controlled by venting into the room via ventilation gaps provided at the ceiling and skirting board levels or via passive air vents, where access through an external wall is available.

Ceilings

14.14 Ceilings to be covered must always have a fall, as per vaulted cellar constructions, to ensure water does not lie against the membrane or a joint. Membrane sheets should have an overlap of 200 mm.

14.15 Delta Qwik-Seal Plugs, or Delta Plugs sealed with butyl rope should be used to fix the membrane to vaulted ceilings. Any sagging of the membrane between fixing points on ceilings should not be great enough for ponding to occur.

14.16 At the end walls of vaulted constructions the membrane must be turned down onto the end wall by a minimum 200 mm. The membrane is mitred as necessary to fit the curve of the ceiling, and the joints sealed with Delta Tape or Rope. The wall membrane should be cut into the curve of the ceiling, fixed in front of the ceiling membrane, and the gap sealed with Delta Rope.

Floors

14.17 Floors should have a drainage outlet point. There should be a fall towards the outlet point or a drainage channel made around the circumference of the floor, to ensure that water can flow to the outlet.

14.18 The membrane is rolled out 'studs down' over the floor, and consecutive membrane widths are laid so the flanged edge overlaps the first sheet by three studs., and the joints sealed in accordance with section 14.2. The joints can then be oversealed using Delta Corner Strip.

14.19 The membrane is cut within 5 mm of any pipes and services in the floor, and the gap filled with Delta Rope. If necessary, a patch of membrane is overlaid and sealed to the services with Delta Rope, and its perimeter sealed with Delta Tape or Delta Corner Strip.

14.20 Fixings must not be applied through the floor membrane.

14.21 Where appropriate, at wall/floor junctions and corners of the installation, the membrane may be cut flush and the gap between the wall and floor membranes sealed with Delta Corner Strip. Alternatively, the floor membrane may be turned up by 100 mm at the wall.

14.22 Where internal or external corners occur, these should be oversealed using Delta Corner Strip, in accordance with the Certificate holder's installation instructions.

15 Dry lining of walls

Gypsum plasterboard to BS EN 520 : 2004, or similar dry lining boards which are the subject of a current BBA Certificate, are fixed to the battens with galvanized screws or nails, positioned a minimum of 12 mm from the edge of the board. Care should be taken to ensure that penetration of the plasterboard screws or nails is less than batten depth to avoid puncturing the membrane.

16 Floor membrane coverings

16.1 If required, extruded closed-cell polystyrene insulation boards, minimum density 30 kg·m⁻³, may be laid over the membrane.

16.2 Suitable tongue-and-groove flooring board panels, should be selected in accordance with BS EN 12871 : 2010, and loose-laid over the membrane to within 10 mm of the walls. The panels are staggered and the joints sealed with a thermoplastic wood adhesive to BS EN 204 : 2001.

16.3 Alternatively, the membrane is covered by concrete or screed of minimum thickness 50 mm (or of minimum thickness 65 mm if laid over insulation boards) in accordance with BS 8204-1 : 2003. Care should be taken to ensure the membrane is not displaced when placing the concrete or screed. The concrete screed should be reinforced to inhibit shrinkage cracks.

16.4 Proprietary screeds, which can generally be laid at thicknesses less than 50 mm, may also be considered but the use of these products with the membrane has not been assessed by the BBA and is outside the scope of this Certificate.

17 Finishing works

After the system has been installed and the walls dry-lined, permanent decorations such as vinyl paper or oil paint, may be applied. Temporary permeable decorations (necessary with traditional, cement-based waterproofers) are not necessary with this system.

Technical Investigations

18 Tests

18.1 Tests were carried out to determine:

- thickness
- melt-flow rate
- water absorption
- water vapour permeability of the membrane incorporating a joint
- resistance to long-term and short-term compression loading
- nail tear resistance
- puncture resistance.

18.2 Independent test reports were examined relating to:

- density
- tensile strength and elongation.

19 Investigations

19.1 A user survey of treated installations and contractors was conducted to establish the system's performance in use.

19.2 Visits were made to sites in progress to assess the practicability of installation in respect of sealing lap joints and corners, dry lining and flooring finishing works.

19.3 An assessment was made of the scope of use and durability of the system in relation to the generic properties of the membrane.

19.4 The manufacturing process and quality control procedures were examined and details were obtained of the quality and composition of the materials used.

Bibliography

- BS 5250 : 2002 *Code of practice for control of condensation in buildings*
- BS 6576 : 2005 *Code of practice for diagnosis of rising damp in walls of buildings and installation of chemical damp-proof courses*
- BS 8102 : 2009 *Code of practice for protection of below ground structures against water from the ground*
- BS 8204-1 : 2003 *Screeds, bases and in-situ floorings — Concrete bases and cement sand levelling screeds to receive floorings — Code of practice*
- BS EN 204 : 2001 *Classification of thermoplastic wood adhesives for non-structural applications*
- BS EN 520 : 2004 *Gypsum plasterboards — Definitions, requirements and test methods*
- BS EN 1991-1-1 : 2002 *Eurocode 1 : Actions on structures — General actions — Densities, self-weight, imposed loads for buildings*
- NA to BS EN 1991-1-1 : 2002 *UK National Annex to Eurocode 1 : Actions on structures — General actions — Densities, self-weight, imposed loads for buildings*
- BS EN 12871 : 2010 *Wood-based panels — Performance specifications and requirements for load bearing boards for use in floors, walls and roofs*
- Property Care Association COP02 *Code of Practice for Installation of Remedial Damp-proof Courses in Masonry Walls*

Conditions of Certification

20 Conditions

20.1 This Certificate:

- relates only to the product/system that is named and described on the front page
- is granted only to the company, firm or person named on the front page — no other company, firm or person may hold or claim any entitlement to this Certificate
- is valid only within the UK
- has to be read, considered and used as a whole document — it may be misleading and will be incomplete to be selective
- is copyright of the BBA
- is subject to English law.

20.2 Publications and documents referred to in this Certificate are those that the BBA deems to be relevant at the date of issue or re-issue of this Certificate and include any: Act of Parliament; Statutory Instrument; Directive; Regulation; British, European or International Standard; Code of Practice; manufacturers' instructions; or any other publication or document similar or related to the aforementioned.

20.3 This Certificate will remain valid for an unlimited period provided that the product/system and the manufacture and/or fabrication including all related and relevant processes thereof:

- are maintained at or above the levels which have been assessed and found to be satisfactory by the BBA
- continue to be checked as and when deemed appropriate by the BBA under arrangements that it will determine
- are reviewed by the BBA as and when it considers appropriate.

20.4 In granting this Certificate, the BBA is not responsible for:

- the presence or absence of any patent, intellectual property or similar rights subsisting in the product/system or any other product/system
- the right of the Certificate holder to manufacture, supply, install, maintain or market the product/system
- individual installations of the product/system, including the nature, design, methods and workmanship of or related to the installation
- the actual works in which the product/system is installed, used and maintained, including the nature, design, methods and workmanship of such works.

20.5 Any information relating to the manufacture, supply, installation, use and maintenance of this product/system which is contained or referred to in this Certificate is the minimum required to be met when the product/system is manufactured, supplied, installed, used and maintained. It does not purport in any way to restate the requirements of the Health & Safety at Work etc Act 1974, or of any other statutory, common law or other duty which may exist at the date of this Certificate; nor is conformity with such information to be taken as satisfying the requirements of the 1974 Act or of any statutory, common law or other duty of care. In granting this Certificate, the BBA does not accept responsibility to any person or body for any loss or damage, including personal injury, arising as a direct or indirect result of the manufacture, supply, installation, use and maintenance of this product/system.

Delta Membrane Systems Ltd

Unit 7
Bassett Business Centre
Hurricane Way
North Weald, Epping
Essex CM16 6AA

Tel: 01992 523811 Fax: 01992 524046
e-mail: info@deltamembranes.com
website: www.deltamembranes.com



Agrément Certificate
00/3742
Product Sheet 2

DELTA MEMBRANE SYSTEMS

DELTA-MS20

PRODUCT SCOPE AND SUMMARY OF CERTIFICATE

This Certificate relates to Delta-MS20, a moulded HDPE membrane for damp-proofing walls, floors and vaulted ceilings in new construction or existing buildings. It can be used above or below ground, over a contaminated or damp background, to support a dry lining and flooring.

AGRÉMENT CERTIFICATION INCLUDES:

- factors relating to compliance with Building Regulations where applicable
- factors relating to additional non-regulatory information where applicable
- independently verified technical specification
- assessment criteria and technical investigations
- design considerations
- installation guidance
- regular surveillance of production
- formal three-yearly review.



KEY FACTORS ASSESSED

Resistance to water and water vapour — the product is water resistant and has a high resistance to water vapour transmission (see section 5).

Resistance to salt transfer — the product provides an effective barrier to the transmission of salts or other contaminants from the substrate (see section 7).

Resistance to puncture, impact and loading — the membrane has a high resistance to puncture and will not be damaged by normal foot traffic during installation, or while laying concrete or screeding. It can support the long-term loadings likely to be experienced in service without undue deformation (see section 8).

Durability — under normal conditions of use the membrane will provide an effective barrier to the transmission of salts, liquid water and water vapour for the life of the structure in which it is incorporated (see section 11).

The BBA has awarded this Agrément Certificate to the company named above for the product described herein. The product has been assessed by the BBA as being fit for its intended use provided it is installed, used and maintained as set out in this Certificate.

On behalf of the British Board of Agrément

A handwritten signature in black ink, appearing to read 'Simon Wroe'.

Simon Wroe
Head of Approvals — Materials

A handwritten signature in black ink, appearing to read 'Greg Cooper'.

Greg Cooper
Chief Executive

Date of Third issue: 2 July 2010

Originally certified on 24 November 2000

The BBA is a UKAS accredited certification body — Number 113. The schedule of the current scope of accreditation for product certification is available in pdf format via the UKAS link on the BBA website at www.bbacerts.co.uk

Readers are advised to check the validity and latest issue number of this Agrément Certificate by either referring to the BBA website or contacting the BBA direct.

British Board of Agrément
Bucknalls Lane
Garston, Watford
Herts WD25 9BA

tel: 01923 665300
fax: 01923 665301
e-mail: mail@bba.star.co.uk
website: www.bbacerts.co.uk

©2010

Regulations

In the opinion of the BBA, Delta-MS20, if used in accordance with the provisions of this Certificate, will meet or contribute to meeting the relevant requirements of the following Building Regulations:



The Building Regulations 2000 (as amended) (England and Wales)

For new construction and a 'Material Change of Use' of an existing building, as defined in Regulation 5a

Requirement:	C2(a)(b)	Resistance to moisture
Comment:		The system adequately resists the passage of moisture. See section 5.1 of this Certificate.
Requirement:	Regulation 7	Materials and workmanship
Comment:		The system is acceptable. See section 11 and the <i>Installation</i> part of this Certificate.



The Building (Scotland) Regulations 2004 (as amended)

For new construction and a 'Conversion' of an existing building, as defined in Regulation 4

Regulation:	8(1)	Fitness and durability of materials and workmanship
Comment:		The system is acceptable. See section 11 and the <i>Installation</i> part of this Certificate.
Regulation:	9	Building standards — construction
Standard:	3.3	Flooding and ground water
Comment:		The system can contribute to minimising or eliminating the effects of flooding on the building fabric and/or the building element, with reference to clause 3.3.1 ⁽¹⁾⁽²⁾ . See section 5.1 of this Certificate.
Standard:	3.4	Moisture from the ground
Comment:		The system adequately resists the passage of moisture, with reference to clauses 3.4.1 ⁽¹⁾⁽²⁾ , 3.4.2 ⁽¹⁾⁽²⁾ , 3.4.5 ⁽¹⁾⁽²⁾ , 3.4.6 ⁽¹⁾⁽²⁾ and 3.4.7 ⁽¹⁾⁽²⁾ . See section 5.1 of this Certificate.
Standard:	3.6(a)	Surface water drainage
Comment:		The system can contribute to satisfying this Standard, with reference to clause 3.6.3 ⁽¹⁾⁽²⁾ . See section 5.1 of this Certificate.
Standard:	3.10	Precipitation
Comment:		The system adequately resists the passage of moisture, with reference to clause 3.10.1 ⁽¹⁾⁽²⁾ . See section 5.1 of this Certificate.
Regulation:	12	Building standards — conversions
Comment:		All comments given for this system under Regulation 9, also apply to this Regulation, with reference to clause 0.12.1 ⁽¹⁾⁽²⁾ and Schedule 6 ⁽¹⁾⁽²⁾ . (1) Technical Handbook (Domestic). (2) Technical Handbook (Non-Domestic).



The Building Regulations (Northern Ireland) 2000 (as amended)

For new construction and a 'Material Change of Use' of an existing building, as defined in Regulation A9

Regulation:	B2	Fitness of materials and workmanship
Comment:		The system is acceptable. See section 11 and the <i>Installation</i> part of this Certificate.
Regulation:	C4(a)(b)	Resistance to ground moisture and weather
Comment:		The system adequately resists the passage of moisture. See section 5.1 of this Certificate.

Construction (Design and Management) Regulations 2007

Construction (Design and Management) Regulations (Northern Ireland) 2007

Information in this Certificate may assist the client, CDM co-ordinator, designer and contractors to address their obligations under these Regulations.

See section: 1 *Description* (1.2) of this Certificate.

Non-regulatory Information

NHBC Standards 2008

NHBC accepts the use of Delta-MS20, when installed and used in accordance with this Certificate, in relation to *NHBC Standards*, Chapter 5.1 *Substructure and ground bearing floors* and 5.2 *Suspended ground floors*.

1 Description

1.1 Delta-MS20 membrane is a brown, high-density polyethylene (HDPE) sheet with moulded studs, for use as a damp-proofing membrane. The membrane is available in the following dimensions:

Thickness (mm)	1.0
Stud height (mm)	20
Weight per unit area ($\text{kg}\cdot\text{m}^{-2}$)	1.0
Roll length (m)	20.0
Roll width (m)	2.0
Weight per roll (kg)	40
Air gap volume ($\text{l}\cdot\text{m}^{-2}$)	14

1.2 The membrane is formed in a continuous process in which HDPE is extruded into sheets and the studs impression formed.

1.3 Quality control is exercised over raw materials, during manufacture and on the final product.

1.4 Ancillary items used with the membrane include:

- Delta Qwik-Seal Plug — a plastic plug supplied with preformed rubber seal for use in masonry walls and concrete (see Figure 1)
- Delta Plug — glass-filled nylon plug for use in masonry walls and concrete (see Figure 2)
- Delta Tape — black butyl tape for sealing joints in the membrane
- Delta Rope — black butyl beading for sealing the membrane around pipes and openings, joining floor and wall membranes, and to seal around the head of the Delta Plugs prior to fixing the membrane
- Delta Mastic — an acrylic sealant for sealing the membrane around pipes and openings
- Delta Corner Strip — a self-adhesive membrane strip for sealing junctions between walls and floors, and for sealing joints at corners.
- Delta Primer — a solvent-based primer for sealing porous substrates prior to application of the Delta range of butyl-based sealing products.

Figure 1 Delta Qwik-Seal Plug fixing detail

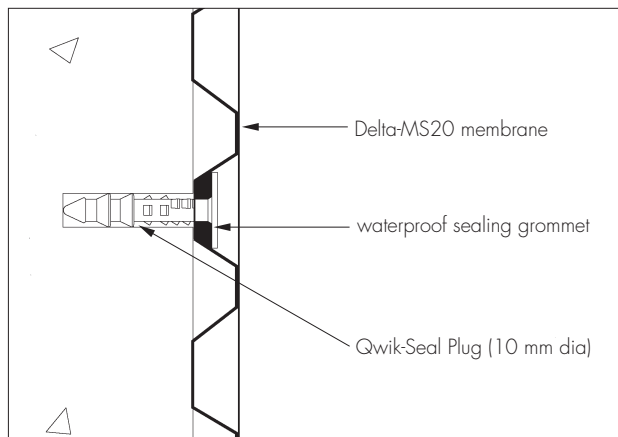
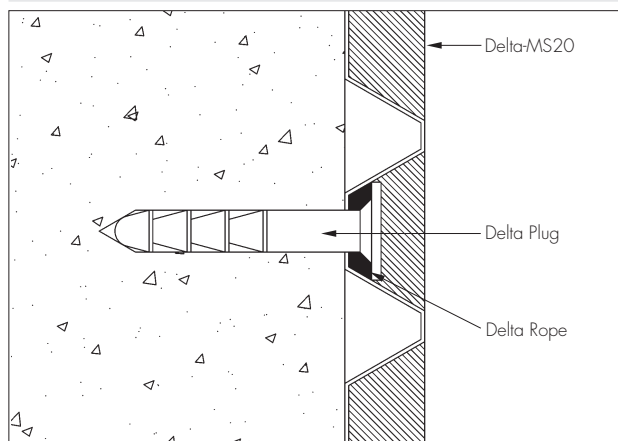

Figure 2 Delta Plug fixing detail



2 Delivery and site handling

2.1 The membrane is delivered to site in rolls secured with outer wrapping, and a headband bearing the product and manufacturer's name.

2.2 Rolls should be stored on end, under cover and protected from sharp objects, sunlight and high temperatures.

2.3 The packaging details of the ancillary items are shown in Table 1.

Item	Dimensions/volume	Packaging/quantity
Delta Qwik-Seal Plug	10 mm diameter 58 mm long	Boxes of 100
Delta Plug	11 mm diameter 70 mm long	boxes of 100 or 1000
Delta Tape	22.5 m long 28 mm wide 2 mm thick	1 roll per box 10 rolls per outer box
Delta Rope	4.75 m long 10 mm diameter	1 roll per box 10 rolls per outer box
Delta Mastic	0.4 litre cartridge	24 cartridges per box
Delta Corner Strip	20 m long 150 mm wide	Single rolls 4 rolls per box
Delta Primer	5 litre	Single 5 litre tin

2.4 Delta Primer is classified as 'harmful' and 'flammable' under *The Chemicals (Hazard Information and Packaging for Supply) Regulations 2009* (CHIP4) and should be stored in a cool place away from naked flames.

Assessment and Technical Investigations

The following is a summary of the assessment and technical investigations carried out on Delta-MS20.

Design Considerations

3 Use

3.1 Delta-MS20 is used as damp-proofing on walls, floors and vaulted ceilings, above and below ground, in new construction or in existing buildings over a contaminated or damp background. It can support a dry lining, screed or flooring, in the following situations:

- on damp walls and floors in underground situations subject to high groundwater levels, and perennial moisture
- on vaulted ceilings of archways or cellars subject to water ingress
- in conjunction with a remedial dpc system where the walls and floors have a high salt content, and/or it is necessary to complete the installation immediately without allowing a period for initial drying
- over walls and floors which have a friable or painted surface, are contaminated (eg with oil or mould), or have a high salt content
- as a waterproofing membrane in areas subject to vibration.

3.2 Depending on the application required and the site conditions, the membrane may be used as:

- an underfloor damp-proof membrane
- a dry lining for walls, ventilated into the room via aeration slots at the top and bottom of the wall or via passive air vents, where access through an external wall is available.
- a sealed system covering wall, floor and ceiling with provision made for disposing of water build-up behind the membrane via a sump and pump.

3.3 The membrane has not been assessed for use in chemically contaminated areas, such as brownfield sites.

3.4 The membrane consists of 1.0 mm thick HDPE and, in the opinion of the BBA, meets the requirement for a radon barrier according to BRE Report (BR 211 : 1999) *Radon : guidance on protective measures for new dwellings*. However, the effectiveness of the joint sealing system used with Delta-MS20 has not been assessed against radon by the BBA and is outside the scope of this Certificate.

3.5 The system is satisfactory for use in Type C (drained protection) constructions in accordance with BS 8102 : 2009.

3.6 Under normal operating conditions the membrane is not affected by underfloor heating.

4 Practicability of installation

The membrane should only be installed by installers who have been trained and approved by the Certificate holder, or by competent specialist contractors.

5 Resistance to water and water vapour



5.1 The membrane is water resistant and has a high resistance to water vapour transmission. However, the system as installed is not resistant to hydrostatic pressure and, consequently, the measures described in the *Installation* part of this Certificate must be followed to ensure that the membrane acts as a drainage layer with no excessive build-up of water behind the system.

5.2 All joints and fixings must be sealed with Delta sealing products, and drainage channels and gullies, or sumps and pumps should be installed as necessary to disperse excess or standing water.

6 Risk of condensation

6.1 As with any room, there is a need to control the generation and dispersal of moisture in the internal environment and to select appropriate and robust designs to minimise the risk of both surface and interstitial condensation, especially where insulation is used over the membrane.

6.2 In common with most waterproofing membranes, the product has a very high resistance to vapour diffusion, and when placed on the cold side of a construction may increase the risk of interstitial condensation. A calculation should be carried out to BS 5250 : 2002 and designers should consider appropriate techniques for managing the safe egress of moisture vapour with care (such as control of the internal room environment or use of a vapour control layer on the warm side of the insulation), and in particular the effect of moisture on any materials at or in contact with materials below the local dew-point.

7 Resistance to salt transfer

The system provides an effective barrier to the transmission of salts or other contaminants from the substrate.

8 Resistance to puncture, impact and loading

8.1 The membrane has a high resistance to puncture and will not be damaged by normal foot traffic during installation or while laying concrete or screeding to BS 8204-1 : 2003.

8.2 The membrane can support the long-term imposed loadings defined in NA to BS EN 1991-1-1 : 2002, Table NA.2, categories A to D, without undue deformation.

9 Wall-mounted fittings

Wall-mounted fittings (apart from lightweight items such as framed pictures) should be fixed where possible into battens, whose position and number of support fixings into the loadbearing structure are predetermined. Only in exceptional circumstances should fittings be fixed (using proprietary fixings) through the membrane and lining board to the loadbearing structure behind. Holes made in the membrane must be repaired in accordance with the Certificate holder's recommended procedures.

10 Maintenance

10.1 As the membrane is confined within a wall or floor space and has suitable durability (see section 11), maintenance is not required.

10.2 Regular maintenance of all gullies, sumps and pumps must be conducted to ensure that a build-up of water does not occur behind the membrane.

11 Durability



Under normal conditions of use the system will provide an effective barrier to the transmission of salts, liquid water and water vapour for the life of the structure in which it is incorporated.

Installation

12 Survey

12.1 Where the property is below ground, or where conditions are damp, a full survey is necessary by a specialist waterproofing surveyor to diagnose the cause and to establish if treatment is required.

12.2 If rising damp to above-ground elevations is found, a remedial treatment is conducted in accordance with the relevant Agrément Certificate, BS 6576 : 2005 and the Property Care Association *Code of Practice for Installation of Remedial Damp-proof Courses in Masonry Walls*, 2006.

12.3 Appropriate remedial measures are taken to rectify major causes of damp conditions or water ingress, and to repair structural defects.

13 Surface preparation

13.1 When used in new constructions, the concrete base must be laid in accordance with BS 8204-1 : 2003.

13.2 If a board covering is to be laid directly on the membrane, the concrete base must have a surface regularity with a maximum permissible departure of 5 mm from the underside of a 2 m straight edge, resting in contact with the floor, in accordance with BS 8204-1 : 2003.

13.3 When used in existing buildings any unsound plaster, render or screed is removed to expose the substrate and cleaned with a stiff brush to remove loose material, laitance, salt residue, mould or adhesive. If mould is present the substrate is treated with a fungicidal wash.

13.4 Uneven floor substrates should be dubbed out with a cement-sand (1:4) or cement-lime-sand (1:1:6) render or screed, to the tolerance described in section 13.2. They should be allowed to dry thoroughly before the Delta-MS20 membrane is installed above.

14 Procedure

General

14.1 Delta-MS20 may be used in combination with any of the appropriate Delta membranes which are the subject of other Product Sheets of this Certificate.

14.2 The membrane should be used by overlapping the previously installed membrane width by a minimum of three studs, which should interlock, and positioning Delta Tape between the last two rows of studs. Alternatively, joints can be over-sealed using Delta Corner Strip.

14.3 Fixings are made through the membrane into 10 mm holes, drilled centrally through the studs. Delta Qwik-Seal Plugs (complete with preformed rubber seal) are inserted into the holes and hammered flush with the membrane with a club hammer. The seal must be compressed to function as a barrier against water ingress, and this should be visually checked as each plug is fixed.

14.4 Alternatively, fixings are made through 11 mm holes, drilled centrally through the studs. Delta Plugs, to which Delta Rope has been applied around the rim, are inserted into the holes and hammered flush with the membrane. The Delta Rope forms a sealing gasket between the plug and the membrane.

14.5 Spacing between fixings will depend on the application and the nature of the substrate, but should be kept to a maximum of one metre.

14.6 On walls and ceilings, preservative-treated timber battens of minimum dimensions 25 mm by 38 mm are fixed into the Delta Plug's fixing hole using No 12 screws, or Delta Qwik-Seal Plug's fixing hole using No 10 screws, with a maximum screwing-in depth of 30 mm. The membrane can also be dry-lined, using free-standing framework, blockwork or similar. Where necessary, these should be tied back by fixing into the Delta Plug, sealed with Delta Rope.

Walls

14.7 Installation of the membrane is usually commenced at the top of the construction. The membrane may require initial fixing on a ceiling or along the upper edge of a wall, prior to final fixings. For joints, the two membrane sheets are overlapped by a minimum of 100 mm, and for horizontal joints the lower sheet is always positioned in front of the upper sheet.

14.8 The installation is conducted over windows and the membrane is cut away to expose them. The surfaces are primed with Delta Primer and the gaps oversealed with Delta Corner Strip.

14.9 For doors and some obstructions the technique covered in section 14.7 cannot be used. Instead, the membrane is installed up to the perimeter and the gap sealed in the same manner.

14.10 Power cables, points and light switches preferably should be remounted in front of the membrane.

14.11 In below-ground installations, the practice of leaving the top of the wall membrane unsealed where there is no requirement for a ceiling membrane to be installed may need to be reconsidered in cases where ingress of gases, odours, or vermin is a consideration (such as in proximity to food preparation areas). The advice of the Certificate holder should be sought in these situations.

14.12 In above-ground installations the build up of water vapour behind the membrane is controlled by ventilating into the room via ventilation gaps provided at the ceiling and skirting board levels or via passive air vents, where access through an external wall is available.

Ceilings

14.13 Ceilings to be covered must always have a fall, as per vaulted cellar constructions, to ensure water does not lie against the membrane or a joint. Membrane sheets should have an overlap of 200 mm.

14.14 Delta Qwik-Seal Plugs, or Delta Plugs sealed with butyl rope should be used to fix the membrane to vaulted ceilings. Any sagging of the membrane between fixing points on ceilings should not be great enough for ponding to occur.

14.15 At the end walls of vaulted constructions the membrane must be turned down onto the end wall by a minimum 200 mm. The membrane is mitred as necessary to fit the curve of the ceiling, and the joints sealed with Delta Tape or Rope. The wall membrane should be cut into the curve of the ceiling, fixed in front of the ceiling membrane, and the joint over-sealed with Delta Corner Strip.

Floors

14.16 Floors should have a drainage outlet point. There should be a fall towards the outlet point or a drainage channel made around the circumference of the floor, to ensure that water can flow to the outlet.

14.17 The membrane is rolled out 'studs down' over the floor, and consecutive membrane widths are laid so that the membrane overlaps the first sheet by three studs and interlocks. The joints are sealed in accordance with section 14.2.

14.18 The membrane is cut within 5 mm of any pipes and services in the floor, and the gap filled with Delta Rope. If necessary, a patch of membrane is overlaid and sealed to the services with Delta Rope, and its perimeter sealed with Delta Tape. Alternatively, Delta Corner Strip can be used to form a seal between the membrane and services.

14.19 Fixings must not be applied through the floor membrane.

14.20 Where appropriate, at wall/floor junctions and corners of the installation, the membrane may be cut flush and the gap between the wall and floor membranes sealed with Delta Corner Strip. Alternatively, the floor membrane may be turned up by 100 mm at the wall.

14.21 Where internal or external corners occur, these should be oversealed using Delta Corner Strip, in accordance with the Certificate holder's installation instructions.

15 Dry lining of walls

Gypsum plasterboard to BS EN 520 : 2004, or similar dry lining boards which are the subject of a current BBA Certificate, are fixed to the battens with galvanized screws or nails, positioned a minimum of 12 mm from the edge of the board. Care should be taken to ensure that penetration of the plasterboard screws or nails is less than batten depth to avoid puncturing the membrane.

16 Finishing works

After the system has been installed and the walls dry-lined, permanent decorations such as vinyl paper or oil paint, may be applied. Temporary permeable decorations (necessary with traditional, cement-based waterproofers) are not necessary with this system.

17 Floor membrane coverings

17.1 If required, extruded closed-cell polystyrene insulation boards, minimum density 30 kg·m⁻³, may be laid over the membrane.

17.2 Suitable tongue-and-groove flooring board panels, should be selected in accordance with BS EN 12871 : 2010, and loose-laid over the membrane to within 10 mm of the walls. The panels are staggered and the joints sealed with a thermoplastic wood adhesive to BS EN 204 : 2001.

17.3 Alternatively, the membrane is covered by concrete or screed a minimum of 50 mm thick (or a minimum of 65 mm thick if laid over insulation boards) in accordance with BS 8204-1 : 2003. Care should be taken to ensure the membrane is not displaced when placing the concrete or screed. The concrete screed should be reinforced to inhibit shrinkage cracks.

17.4 Proprietary screeds may also be considered, which can generally be laid at thicknesses less than 65 mm, but the use of these products with the membrane has not been assessed by the BBA and is outside the scope of this Certificate.

Technical Investigations

18 Tests

18.1 Tests were carried out to determine:

- thickness.

18.2 Independent test reports were examined relating to:

- density tensile strength and elongation.

19 Investigations

19.1 A user survey of treated installations and contractors was conducted to establish the system's performance in use.

19.2 An assessment was made of the effectiveness of the sealing system based on data obtained during the assessment of Delta-MS500 membrane.

19.3 An assessment was made of the scope of use and durability of the system in relation to the generic properties of the membrane.

19.4 The manufacturing process and quality control procedures were examined and details were obtained of the quality and composition of the materials used.

Bibliography

BS 5250 : 2002 *Code of practice for control of condensation in buildings*

BS 6576 : 2005 *Code of practice for diagnosis of rising damp in walls of buildings and installation of chemical damp-proof courses*

BS 8102 : 2009 *Code of practice for protection of below ground structures against water from the ground*

BS 8204-1 : 2003 *Screeds, bases and in-situ floorings — Concrete bases and cement sand levelling screeds to receive floorings — Code of practice*

BS EN 204 : 2001 *Classification of thermoplastic wood adhesives for non-structural applications*

BS EN 520 : 2004 *Gypsum plasterboards — Definitions, requirements and test methods*

BS EN 1991-1-1 : 2002 *Eurocode 1 : Actions on structures — General actions— Densities, self-weight, imposed loads for buildings*

NA to BS EN 1991-1-1 : 2002 *UK National Annex to Eurocode 1 : Actions on structures — General actions— Densities, self-weight, imposed loads for buildings*

BS EN 12871 : 2010 *Wood-based panels — Performance specifications and requirements for load bearing boards for use in floors, walls and roofs*

Property Care Association COP02 Code of Practice for Installation of Remedial Damp-proof Courses in Masonry Walls

Conditions of Certification

20 Conditions

20.1 This Certificate:

- relates only to the product/system that is named and described on the front page
- is granted only to the company, firm or person named on the front page — no other company, firm or person may hold or claim any entitlement to this Certificate
- is valid only within the UK
- has to be read, considered and used as a whole document — it may be misleading and will be incomplete to be selective
- is copyright of the BBA
- is subject to English law.

20.2 Publications and documents referred to in this Certificate are those that the BBA deems to be relevant at the date of issue or re-issue of this Certificate and include any: Act of Parliament; Statutory Instrument; Directive; Regulation; British, European or International Standard; Code of Practice; manufacturers' instructions; or any other publication or document similar or related to the aforementioned.

20.3 This Certificate will remain valid for an unlimited period provided that the product/system and the manufacture and/or fabrication including all related and relevant processes thereof:

- are maintained at or above the levels which have been assessed and found to be satisfactory by the BBA
- continue to be checked as and when deemed appropriate by the BBA under arrangements that it will determine
- are reviewed by the BBA as and when it considers appropriate.

20.4 In granting this Certificate, the BBA is not responsible for:

- the presence or absence of any patent, intellectual property or similar rights subsisting in the product/system or any other product/system
- the right of the Certificate holder to manufacture, supply, install, maintain or market the product/system
- individual installations of the product/system, including the nature, design, methods and workmanship of or related to the installation
- the actual works in which the product/system is installed, used and maintained, including the nature, design, methods and workmanship of such works.

20.5 Any information relating to the manufacture, supply, installation, use and maintenance of this product/system which is contained or referred to in this Certificate is the minimum required to be met when the product/system is manufactured, supplied, installed, used and maintained. It does not purport in any way to restate the requirements of the Health & Safety at Work etc Act 1974, or of any other statutory, common law or other duty which may exist at the date of this Certificate; nor is conformity with such information to be taken as satisfying the requirements of the 1974 Act or of any statutory, common law or other duty of care. In granting this Certificate, the BBA does not accept responsibility to any person or body for any loss or damage, including personal injury, arising as a direct or indirect result of the manufacture, supply, installation, use and maintenance of this product/system.

Delta Membrane Systems Ltd

Unit 7
Bassett Business Centre
Hurricane Way
North Weald, Epping
Essex CM16 6AA

Tel: 01992 523811 Fax: 01992 524046
e-mail: info@deltamembranes.com
website: www.deltamembranes.com



Agrément Certificate
00/3742
Product Sheet 3

DELTA MEMBRANE SYSTEMS

DELTA-PT

PRODUCT SCOPE AND SUMMARY OF CERTIFICATE

This Certificate relates to Delta-PT, a moulded HDPE membrane incorporating a polypropylene mesh as a key for plaster, render or dry lining applied on plaster dabs, for use in new construction or existing buildings. It can be used for waterproofing and damp-proofing on walls and vaulted ceilings, above or below ground, over a contaminated or damp background. It can also be used externally as a waterproof support for render.

AGRÉMENT CERTIFICATION INCLUDES:

- factors relating to compliance with Building Regulations where applicable
- factors relating to additional non-regulatory information where applicable
- independently verified technical specification
- assessment criteria and technical investigations
- design considerations
- installation guidance
- regular surveillance of production
- formal three-yearly review.



KEY FACTORS ASSESSED

Resistance to water and water vapour — the membrane is water resistant and has a high resistance to water vapour transmission (see section 5).

Resistance to salt transfer — the membrane provides an effective barrier to the transmission of salts or other contaminants from the substrate (see section 7).

Resistance to impact — the membrane, plastered, rendered or dry-lined, has a satisfactory resistance to soft and hard body impacts (see section 8).

Durability — under normal conditions of use the system will provide an effective barrier to the transmission of salts, liquid water and water vapour for the life of the structure in which it is incorporated (see section 11).

The BBA has awarded this Agrément Certificate to the company named above for the product described herein. The product has been assessed by the BBA as being fit for its intended use provided it is installed, used and maintained as set out in this Certificate.

On behalf of the British Board of Agrément

Simon Wroe
Head of Approvals — Materials

Greg Cooper
Chief Executive

Date of Third issue: 2 July 2010

Originally certificated on 24 November 2000

The BBA is a UKAS accredited certification body — Number 113. The schedule of the current scope of accreditation for product certification is available in pdf format via the UKAS link on the BBA website at www.bbacerts.co.uk

Readers are advised to check the validity and latest issue number of this Agrément Certificate by either referring to the BBA website or contacting the BBA direct.

British Board of Agrément
Bucknalls Lane
Garston, Watford
Herts WD25 9BA

©2010

tel: 01923 665300
fax: 01923 665301
e-mail: mail@bba.star.co.uk
website: www.bbacerts.co.uk

Regulations

In the opinion of the BBA, Delta-PT, if used in accordance with the provisions of this Certificate, will meet or contribute to meeting the relevant requirements of the following Building Regulations:



The Building Regulations 2000 (as amended) (England and Wales)

For new construction and a 'Material Change of Use' of an existing building, as defined in Regulation 5a

Requirement:	C2(a)(b)	Resistance to moisture
Comment:		The system adequately resists the passage of moisture. See section 5.1 of this Certificate.
Requirement:	Regulation 7	Materials and workmanship
Comment:		The system is acceptable. See section 11 and the <i>Installation</i> part of this Certificate.



The Building (Scotland) Regulations 2004 (as amended)

For new construction and a 'Conversion' of an existing building, as defined in Regulation 4

Regulation:	8(1)	Fitness and durability of materials and workmanship
Comment:		The system is acceptable. See section 11 and the <i>Installation</i> part of this Certificate.
Regulation:	9	Building standards — construction
Standard:	3.3	Flooding and ground water
Comment:		The system can contribute to minimising or eliminating the effects of flooding on the building fabric and/or the building element, with reference to clause 3.3.1 ⁽¹⁾⁽²⁾ . See section 5.1 of this Certificate.
Standard:	3.4	Moisture from the ground
Comment:		The system adequately resists the passage of moisture, with reference to clauses 3.4.1 ⁽¹⁾⁽²⁾ , 3.4.2 ⁽¹⁾⁽²⁾ , 3.4.5 ⁽¹⁾⁽²⁾ , 3.4.6 ⁽¹⁾⁽²⁾ and 3.4.7 ⁽¹⁾⁽²⁾ . See section 5.1 of this Certificate.
Standard:	3.6(a)	Surface water drainage
Comment:		The system can contribute to satisfying this Standard, with reference to clause 3.6.3 ⁽¹⁾⁽²⁾ . See section 5.1 of this Certificate.
Standard:	3.10	Precipitation
Comment:		The system adequately resists the passage of moisture, with reference to clause 3.10.1 ⁽¹⁾⁽²⁾ . See section 5.1 of this Certificate.
Regulation:	12	Building standards — conversions
Comment:		All comments given for this system under Regulation 9, also apply to this Regulation, with reference to clause 0.12.1 ⁽¹⁾⁽²⁾ and Schedule 6 ⁽¹⁾⁽²⁾ . (1) Technical Handbook (Domestic). (2) Technical Handbook (Non-Domestic).



The Building Regulations (Northern Ireland) 2000 (as amended)

For new construction and a 'Material Change of Use' of an existing building, as defined in Regulation A9

Regulation:	B2	Fitness of materials and workmanship
Comment:		The system is acceptable. See section 11 and the <i>Installation</i> part of this Certificate.
Regulation:	C4(a)(b)	Resistance to ground moisture and weather
Comment:		The system adequately resists the passage of moisture. See section 5.1 of this Certificate.

Construction (Design and Management) Regulations 2007

Construction (Design and Management) Regulations (Northern Ireland) 2007

Information in this Certificate may assist the client, CDM co-ordinator, designer and contractors to address their obligations under these Regulations.

See section: 1 *Description* (1.2) of this Certificate.

Non-regulatory Information

NHBC Standards 2008

NHBC accepts the use of Delta-PT, when installed and used in accordance with this Certificate, in relation to *NHBC Standards*, Chapter 5.1 *Substructure and ground bearing floors*, 5.2 *Suspended ground floors* and 6.1 *External masonry walls*.

1 Description

1.1 Delta-PT membrane is a brown or clear, high-density polyethylene (HDPE) sheet with moulded studs. It has a woven polypropylene mesh thermally bonded to the membrane on the face side to form a key for plaster and render finishes (see Figure 1).

Figure 1 The membrane

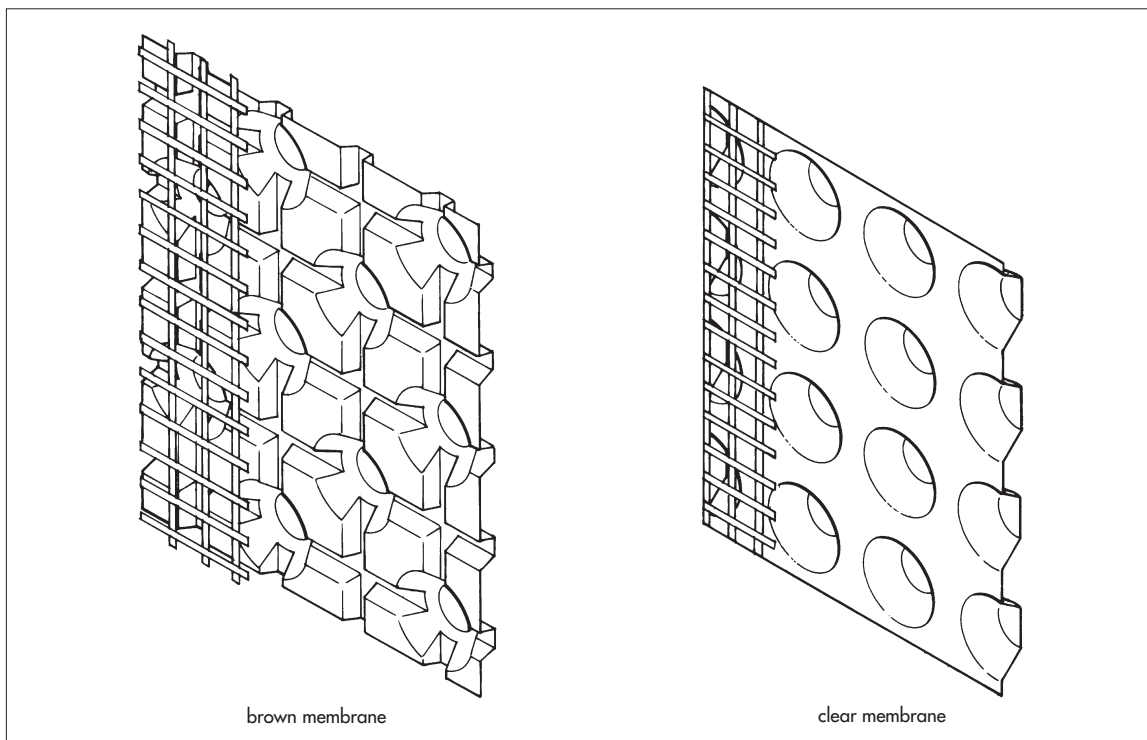

1.2 The membrane is available in the following dimensions:

Thickness (mm)	0.5
Stud height (mm)	8.0
Weight per unit area ($\text{kg}\cdot\text{m}^{-2}$)	0.53
Roll size (m)	1.5 x 10 ⁽¹⁾ and 2.0 x 20 ⁽²⁾
Weight per roll (kg)	9 and 24
Air gap volume ($\text{l}\cdot\text{m}^{-2}$)	5.5

(1) Includes a 100 mm mesh-free area for overlapping sheets.

(2) Includes a 200 mm mesh-free area for overlapping sheets.

1.2 The membrane is formed in a continuous process in which HDPE is extruded into sheets and the studs impression formed. A woven polypropylene mesh is then thermally welded onto the face side of the membrane.

1.3 Quality control is exercised over raw materials, during manufacture and on the final product.

1.4 Ancillary items used with the membrane include:

- Delta-PT Plug — white, polypropylene fixing plug with a grooved shank for use in masonry walls and concrete. This plug requires butyl rope to be applied around the shank before use (see Figure 3)
- Delta-PT Plug with grommet — white, polypropylene fixing plug supplied with preformed rubber seal for use in masonry walls and concrete (see Figure 2)
- Delta Qwik-Seal Plug — a plastic plug supplied with preformed rubber seal for use in masonry walls and concrete (see Figure 4)
- Delta-PT Profile — a plastic edging strip to assist ventilation of the rear face of the membrane, and to act as a plaster stop
- Delta Tape — black butyl tape for sealing joints in the membrane
- Delta Rope — black butyl beading for sealing the membrane around pipes and openings, joining floor and wall membranes, and to seal around the head of the Delta-PT Plugs prior to fixing the membrane
- Delta Mastic — an acrylic sealant for sealing the membrane around pipes and openings
- Delta Corner Strip — a self-adhesive membrane strip for sealing junctions between walls and floors, and for sealing joints at corners
- Delta Primer — a solvent-based primer for sealing porous substrates prior to application of the Delta range of butyl-based sealing products.

Figure 2 Delta-PT Plug with grommet fixing detail

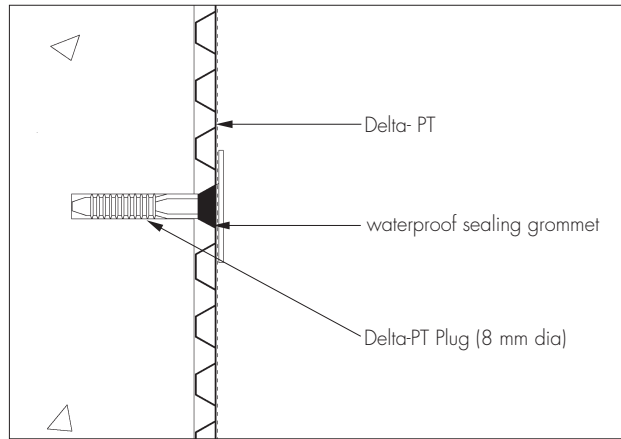

Figure 3 Delta-PT Plug fixing detail

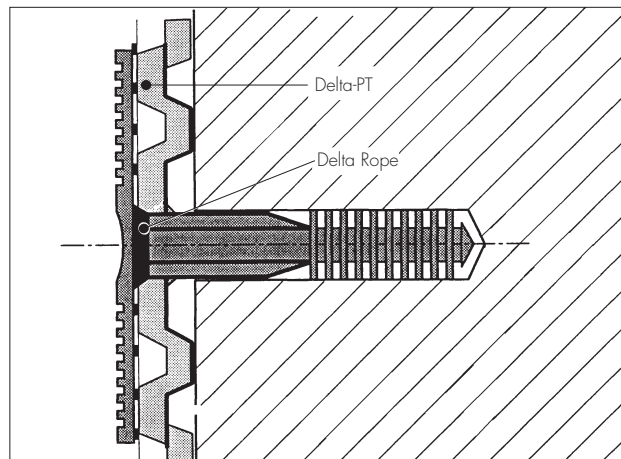
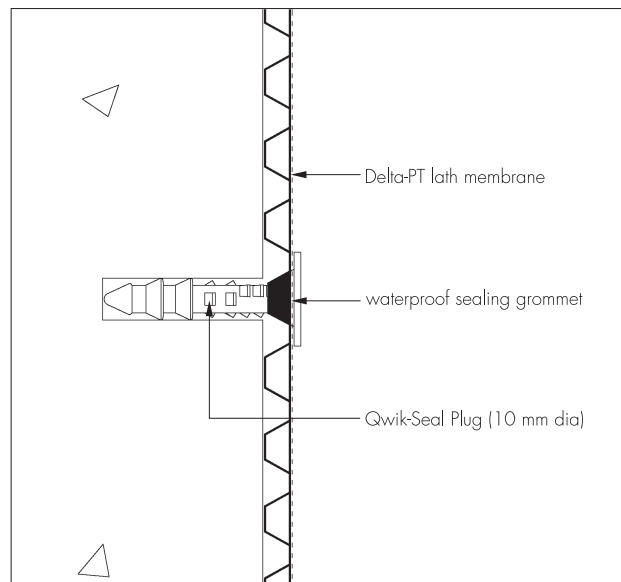

Figure 4 Delta Qwik-Seal Plug fixing detail



2 Delivery and site handling

- 2.1 The membrane is delivered to site in rolls secured with outer wrapping, and a headband bearing the product and manufacturer's name.
- 2.2 Rolls should be stored on end, under cover and protected from sharp objects, sunlight and high temperatures.
- 2.3 The packaging details of the ancillary items are shown in Table 1.

Item	Dimensions/volume	Packaging/quantity
Delta-PT Plug with grommet	8 mm diameter 52 mm long	Boxes of 250
Delta-PT Plug	8 mm diameter 52 mm long	Boxes of 250 or 2000
Delta Qwik-Seal Plug	10mm diameter 58mm long	Boxes of 100
Delta-PT Profile	2 m strips	Single or bundles of 20
Delta Tape	22.5 m long 28 mm wide 2 mm thick	1 roll per box 10 rolls per outer box
Delta Rope	4.75 m long 10 mm diameter	1 roll per box 10 rolls per outer box
Delta Mastic	0.4 litre cartridge	24 cartridges per box
Delta Corner Strip	20 m long 150 mm wide	Single rolls 4 rolls per box
Delta Primer	5 litre	Single 5 litre tin

2.4 Delta Primer is classified as 'harmful' and 'flammable' under *The Chemicals (Hazard Information and Packaging for Supply) Regulations 2009* (CHIP4) and should be stored in a cool place away from naked flames.

Assessment and Technical Investigations

The following is a summary of the assessment and technical investigations carried out on Delta-PT.

Design Considerations

3 Use

3.1 Delta-PT is used for waterproofing and damp-proofing on internal and external walls, and vaulted ceilings, above and below ground, in new construction or in existing buildings over a contaminated or damp background. It can support plastering, rendering or a dry lining fixed by plaster dabs (where appropriate) in the following situations:

- on damp walls in underground situations subject to high groundwater levels, and perennial moisture
- on vaulted ceilings of archways or cellars subject to water ingress
- in conjunction with a remedial dpc system where the walls have a high salt content, and/or it is necessary to complete the installation immediately without allowing a period for initial drying
- over walls which have a friable or painted surface, are contaminated with oil or mould, or have a high salt content
- as a waterproofing membrane in areas subject to vibration.

3.2 Depending on the application required and the site conditions, the membrane may be used as:

- a dry lining for walls, ventilated into the room via aeration slots at the top and bottom of the wall or via passive air vents, where access through an external wall is available
- a sealed system covering wall, floor and ceiling with provision made for disposing of water build-up behind the membrane via a sump and pump.

3.3 The membrane has not been assessed for use in chemically contaminated areas, such as brownfield sites.

3.4 The membrane consists of 0.5 mm thick HDPE and, in the opinion of the BBA, meets the requirement for a radon barrier according to BRE Report (BR 211 : 1999) *Radon : guidance on protective measures for new dwellings*. However, the effectiveness of the joint sealing system used with Delta-PT has not been assessed against radon by the BBA and is outside the scope of this Certificate.

3.5 The system is satisfactory for use in Type C (drained protection) constructions in accordance with BS 8102 : 2009.

4 Practicability of installation

The membrane should only be installed by installers who have been trained and approved by the Certificate holder, or by competent specialist contractors.

5 Resistance to water and water vapour

5.1 The membrane is water resistant and has a high resistance to water vapour transmission. However, the system as installed is not resistant to hydrostatic pressure and, consequently, the measures described in the *Installation* part of this Certificate must be followed to ensure that the membrane acts as a drainage layer with no excessive build-up of water behind the system.

5.2 All joints and fixings must be sealed with Delta sealing products, and drainage channels and gullies, or sumps and pumps should be installed as necessary to disperse excess or standing water.

6 Risk of condensation

As with any room, there is a need to control the generation and dispersal of moisture in the internal environment and to select appropriate and robust designs to minimise the risk of both surface and interstitial condensation.

7 Resistance to salt transfer

The membrane provides an effective barrier to the transmission of salts or other contaminants from the substrate.

8 Resistance to impact

The membrane plastered, rendered or dry lined, has a satisfactory resistance to soft and hard body impacts.

9 Wall-mounted fittings

Wall-mounted fittings (apart from lightweight items such as framed pictures) should be fixed (using recommended proprietary fixings) through the membrane and lining board, plaster or render to the loadbearing structure behind. Holes made in the membrane must be filled with a flexible sealant before inserting the fixing.

10 Maintenance

10.1 As the membrane is covered by plaster, render or plasterboard and has suitable durability (see section 11), maintenance is not required.

10.2 Regular maintenance of all gullies, sumps and pumps must be conducted to ensure that a build-up of water does not occur behind the membrane.

11 Durability



Under normal conditions of use the system will provide an effective barrier to the transmission of salts, liquid water and water vapour for the life of the structure in which it is incorporated.

Installation

12 Survey

12.1 Where the property is below ground, or where conditions are damp, a full survey is necessary by a specialist waterproofing surveyor to diagnose the cause and to establish if treatment is required.

12.2 If rising damp to above ground elevations is found, a remedial treatment is conducted in accordance with the relevant Agrément Certificate, BS 6576 : 2005 and the Property Care Association *Code of Practice for Installation of Remedial Damp-proof Courses in Masonry Walls*, 2006.

12.3 Appropriate remedial measures are taken to rectify major causes of damp conditions or water ingress, and to repair structural defects.

13 Surface preparation

13.1 When used in existing buildings any unsound plaster, render or screed is removed to expose the substrate and cleaned with a stiff brush to remove loose material, laitance, salt residue, mould or adhesive. If mould is present the substrate is treated with a fungicidal wash.

13.2 Uneven substrates should be dubbed out with a cement-sand (1:4) or cement-lime-sand (1:1:6) render, to achieve a flat finish. They should be allowed to dry thoroughly before the Delta-PT membrane is installed.

14 Procedure

General

14.1 Delta-PT may be used in combination with any of the appropriate Delta membranes which are the subject of other Product Sheets of this Certificate.

14.2 Internally, the membrane should always be used with the lower sheet placed in front of the higher sheet. Externally, the lower sheet should always be placed behind the higher sheet.

14.3 Fixings are made through the membrane into holes drilled centrally through the studs to a depth of at least 55 mm. When using Delta-PT Plugs (complete with preformed rubber seal) drill an 8 mm diameter hole, and when using Delta Qwik-Seal Plugs drill a 10 mm diameter hole. Insert the plugs into the holes and hammer flush with the membrane using a club hammer. The seal must be compressed to function as a barrier against water ingress, and this should be visually checked as each plug is fixed. Alternatively, Delta-PT Plugs to which Delta Rope has been applied around the rim, are inserted into the holes and hammered flush with the membrane. The Delta Rope forms a sealing gasket between the plug and the membrane.

14.4 Fixings are made at a maximum spacing of 250 mm for internal plastered or dry-lined situations, and a maximum of 150 mm for external rendered situations.

14.5 Joints between membranes are formed in two ways. If the unmeshed edge of a sheet is used, then an overlap of at least 100 mm is used, with fixings made through both membranes and substrate, and the sheets sealed with Delta Rope, Tape or Mastic. If the unmeshed edge is not available, then an overlap between sheets of 200 mm is used and sealed with Delta Mastic.

14.6 On difficult substrates, the use of the translucent membrane allows the contractor to view the substrate through the membrane and choose the optimum site for each fixing.

Walls

14.7 Installation of the membrane is usually commenced at the top of the construction. The membrane may require initial fixing on a ceiling or along the upper edge of a wall, prior to final fixing. For above ground installations, ventilation gaps of 10 mm are left at ceiling and floor level and finished using Delta-PT Profile (see Figures 5 and 6).

Figure 5 Skirting details

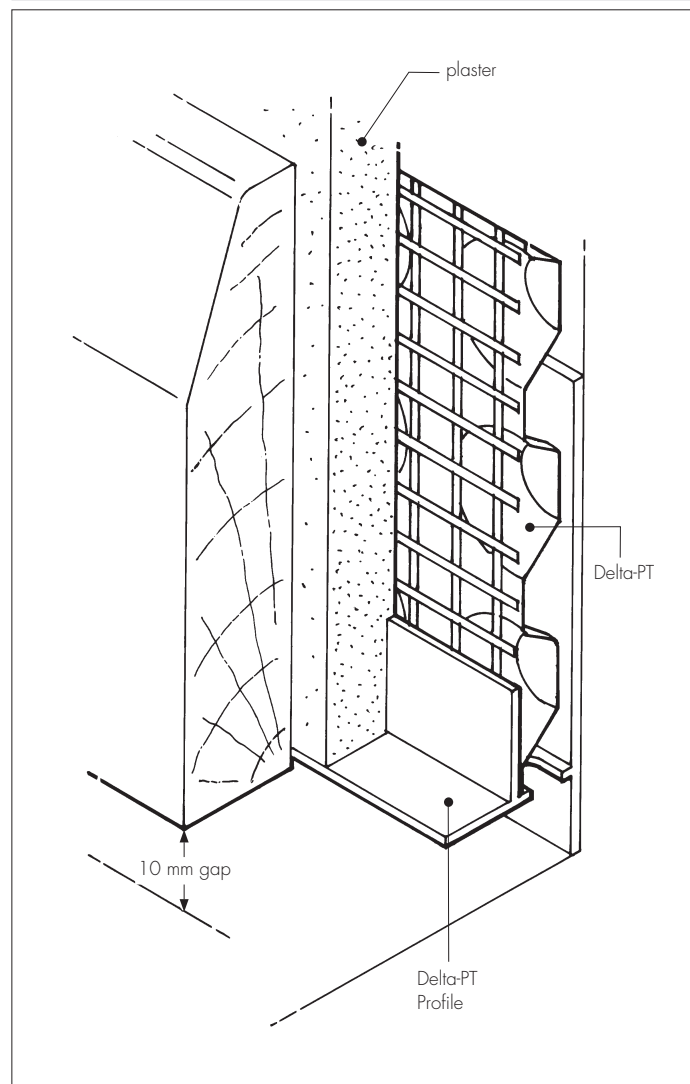
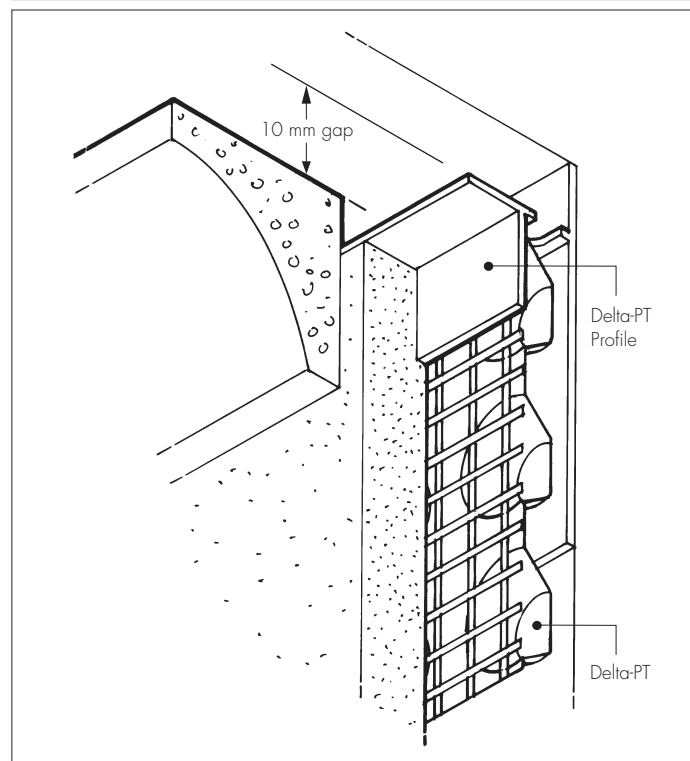

Figure 6 Coving details



14.8 Where there is access to an external wall, the cavity behind the membrane may be vented via air bricks or passive vents. In this case the internal ventilation gaps shown in Figures 3 and 4 may not be necessary.

14.9 The installation is conducted over windows and the membrane is cut away to expose them. The gaps are then sealed with Delta Tape or Delta Rope.

14.10 For doors and some obstructions the technique covered in section 14.8 cannot be used. Instead, the membrane is installed up to the perimeter and the gap sealed in the same manner.

14.11 Power cables, points and light switches preferably should be remounted in front of the membrane.

Ceilings

14.12 Ceilings to be covered must always have a fall, as per vaulted cellar constructions, to ensure water does not lie against the membrane or a joint. Membrane sheets should have an overlap of 200 mm.

14.13 Delta Qwik-Seal Plugs, or Delta Plugs sealed with butyl rope should be used to fix the membrane to vaulted ceilings. Any sagging of the membrane between fixing points on ceilings should not be great enough for ponding to occur.

14.14 At the end walls of vaulted constructions the membrane must be turned down onto the end wall by a minimum 200 mm. The membrane is mitred as necessary to fit the curve of the ceiling, and the joint sealed with Delta Rope. The wall membrane should be cut into the curve of the ceiling, fixed in front of the ceiling membrane, and the gap sealed with Delta Rope.

15 Plastering

15.1 The membrane should be plastered with a plaster recommended by the Certificate holder in accordance with BS 8481 : 2006, BS EN 13914-2 : 2005 and/or the appropriate BBA Certificate.

15.2 The plaster should be a minimum total depth of 15 mm, applied in accordance with the manufacturer's instructions

16 Rendering

16.1 Where Delta-PT has been used externally, it must be rendered with a cement:lime:sand (1:1:6) mix applied to a total thickness of 20 mm in accordance with BS 8481 : 2006.

16.2 The render should be applied in three coats, allowing 7 to 10 days between coats.

16.3 Due to the difference in thermal characteristics between Delta-PT and the render, expansion joints through the render to the membrane must be trowelled in along each lap joint to reduce the possibility of cracking. The joints must be filled with a suitable flexible polymer-based sealant.

16.4 A proprietary polymer/fibre modified render may be used, applied in two coats to a minimum thickness of 25 mm. In such cases, expansion joints must be provided in accordance with recommendation from the Certificate holder and render manufacturer.

16.5 Using the Delta-PT Profile, a 5 mm ventilation gap at the top, and at least 10 mm at the bottom, should be left to assist ventilation of the air gap behind the membrane.

16.6 Where a sand-cement mix is to be used internally, two coats 7 to 8 mm thick are applied, finished with a 3 mm thick gypsum-based skim coat.

17 Dry lining of walls

17.1 A gypsum-based drywall adhesive to BS EN 14496 : 2005 is mixed and applied in vertical strips over the fixing centres and in bands along the top and bottom of the membrane. The adhesive dabs are applied to a minimum thickness of 8 mm and should cover a minimum of 50% of the membrane.

17.2 Gypsum plasterboards to BS EN 520 : 2004, or similar dry lining boards which are the subject of a current BBA Certificate, are pressed onto the adhesive dabs and jointed in the usual manner. Temporary spacers approximately 25 mm high are positioned under the dry lining to support it during the cure period.

18 Finishing works

18.1 In above-ground installations, skirting boards are fixed to the finished walls with a 10 mm gap between the skirting and the floor, and ceiling covings are fixed with a 10 mm gap between the coving and the ceiling, to assist ventilation (see Figures 5 and 6). Alternatively, a proprietary ventilated skirting board or ceiling coving can be used. Where the system is vented through an external wall, (see section 14.8), these gaps will not be necessary.

18.2 After the system has been installed and the walls dry lined, permanent decorations, such as vinyl paper or oil paint, may be applied. Temporary permeable decorations (necessary with traditional, cement-based waterproofers) are not necessary for use with this system.

Technical Investigations

19 Tests

Tests were carried out to determine:

- thickness
- impact resistance of plastered and rendered membrane
- bond strength of mesh to membrane.

20 Investigations

20.1 A user survey of treated installations and contractors was conducted to establish the system's performance in use.

20.2 Trial installations were conducted to assess the practicability of installation of the system and the methods used for plastering and rendering.

20.3 An assessment was made of the scope of use and durability of the system in relation to the generic properties of the membrane and investigations carried out previously on the Delta-MS500 membrane.

20.4 The manufacturing process and quality control procedures were examined and details were obtained of the quality and composition of the materials used.

Bibliography

- BS 6576 : 2005 *Code of practice for diagnosis of rising damp in walls of buildings and installation of chemical damp-proof courses*
- BS 8102 : 2009 *Code of practice for protection of below ground structures against water from the ground*
- BS 8481 : 2006 *Design, preparation and application of internal gypsum, cement, cement and lime plastering systems — Specification*
- BS EN 520 : 2004 *Gypsum plasterboards — Definitions, requirements and test methods*
- BS EN 13914-2 : 2005 *Design, preparation and application of external rendering and internal plastering — Design considerations and essential principles for internal plastering*
- BS EN 14496 : 2005 *Gypsum based adhesives for thermal/acoustic insulation composite panels and plasterboards — Definitions, requirements and test methods*
- Property Care Association COP02 *Code of Practice for Installation of Remedial Damp-proof Courses in Masonry Walls*

21 Conditions

21.1 This Certificate:

- relates only to the product/system that is named and described on the front page
- is granted only to the company, firm or person named on the front page — no other company, firm or person may hold or claim any entitlement to this Certificate
- is valid only within the UK
- has to be read, considered and used as a whole document — it may be misleading and will be incomplete to be selective
- is copyright of the BBA
- is subject to English law.

21.2 Publications and documents referred to in this Certificate are those that the BBA deems to be relevant at the date of issue or re-issue of this Certificate and include any: Act of Parliament; Statutory Instrument; Directive; Regulation; British, European or International Standard; Code of Practice; manufacturers' instructions; or any other publication or document similar or related to the aforementioned.

21.3 This Certificate will remain valid for an unlimited period provided that the product/system and the manufacture and/or fabrication including all related and relevant processes thereof:

- are maintained at or above the levels which have been assessed and found to be satisfactory by the BBA
- continue to be checked as and when deemed appropriate by the BBA under arrangements that it will determine
- are reviewed by the BBA as and when it considers appropriate.

21.4 In granting this Certificate, the BBA is not responsible for:

- the presence or absence of any patent, intellectual property or similar rights subsisting in the product/system or any other product/system
- the right of the Certificate holder to manufacture, supply, install, maintain or market the product/system
- individual installations of the product/system, including the nature, design, methods and workmanship of or related to the installation
- the actual works in which the product/system is installed, used and maintained, including the nature, design, methods and workmanship of such works.

21.5 Any information relating to the manufacture, supply, installation, use and maintenance of this product/system which is contained or referred to in this Certificate is the minimum required to be met when the product/system is manufactured, supplied, installed, used and maintained. It does not purport in any way to restate the requirements of the Health & Safety at Work etc Act 1974, or of any other statutory, common law or other duty which may exist at the date of this Certificate; nor is conformity with such information to be taken as satisfying the requirements of the 1974 Act or of any statutory, common law or other duty of care. In granting this Certificate, the BBA does not accept responsibility to any person or body for any loss or damage, including personal injury, arising as a direct or indirect result of the manufacture, supply, installation, use and maintenance of this product/system.

Delta Membrane Systems Ltd

Unit 7
Bassett Business Centre
Hurricane Way
North Weald, Epping
Essex CM16 6AA

Tel: 01992 523811 Fax: 01992 524046
e-mail: info@deltamembranes.com
website: www.deltamembranes.com



Agrément Certificate
00/3742
Product Sheet 4

DELTA MEMBRANE SYSTEMS

DELTA-FM

PRODUCT SCOPE AND SUMMARY OF CERTIFICATE

This Certificate relates to Delta-FM, a moulded HDPE membrane for damp-proofing walls, floors and vaulted ceilings in new construction or existing buildings. It can be used above or below ground, over a contaminated or damp background, to support a dry lining and flooring.

AGRÉMENT CERTIFICATION INCLUDES:

- factors relating to compliance with Building Regulations where applicable
- factors relating to additional non-regulatory information where applicable
- independently verified technical specification
- assessment criteria and technical investigations
- design considerations
- installation guidance
- regular surveillance of production
- formal three-yearly review.

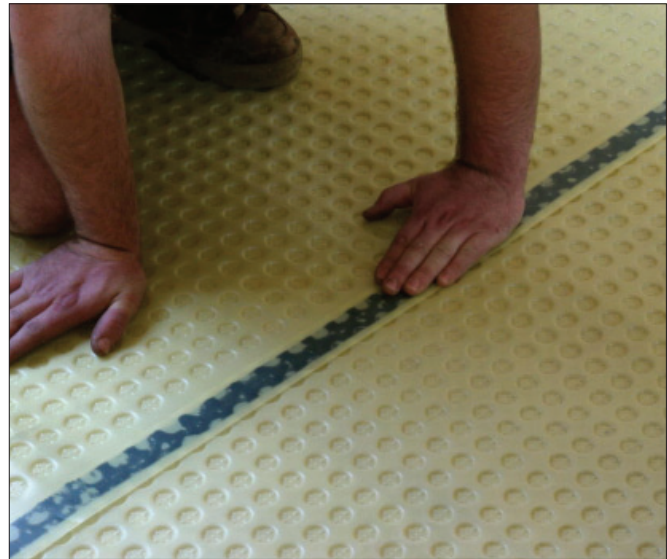

KEY FACTORS ASSESSED

Resistance to water and water vapour — the product is water resistant and has a high resistance to water vapour transmission (see section 5).

Resistance to salt transfer — the product provides an effective barrier to the transmission of salts or other contaminants from the substrate (see section 7).

Resistance to puncture, impact and loading — the membrane has a high resistance to puncture and will not be damaged by normal foot traffic during installation, or while laying concrete, or screeding. It can support the long-term loadings likely to be experienced in service without undue deformation (see section 8).

Durability — under normal conditions of use the system will provide an effective barrier to the transmission of salts, liquid water and water vapour for the life of the structure in which it is incorporated (see section 11).

The BBA has awarded this Agrément Certificate to the company named above for the product described herein. The product has been assessed by the BBA as being fit for its intended use provided it is installed, used and maintained as set out in this Certificate.

On behalf of the British Board of Agrément

A handwritten signature in black ink, appearing to read 'Simon Wroe'.

Simon Wroe
Head of Approvals — Materials

A handwritten signature in black ink, appearing to read 'Greg Cooper'.

Greg Cooper
Chief Executive

Date of Second issue: 2 July 2010

Originally certificated on 24 December 2007

The BBA is a UKAS accredited certification body — Number 113. The schedule of the current scope of accreditation for product certification is available in pdf format via the UKAS link on the BBA website at www.bbacerts.co.uk

Readers are advised to check the validity and latest issue number of this Agrément Certificate by either referring to the BBA website or contacting the BBA direct.

British Board of Agrément
Bucknalls Lane
Garston, Watford
Herts WD25 9BA

©2010

tel: 01923 665300
fax: 01923 665301
e-mail: mail@bba.star.co.uk
website: www.bbacerts.co.uk

Regulations

In the opinion of the BBA, Delta-FM, if used in accordance with the provisions of this Certificate, will meet or contribute to meeting the relevant requirements of the following Building Regulations:



The Building Regulations 2000 (as amended) (England and Wales)

For new construction and a 'Material Change of Use' of an existing building, as defined in Regulation 5a

Requirement:	C2(a)(b)	Resistance to moisture
Comment:		The system adequately resists the passage of moisture. See section 5.1 of this Certificate.
Requirement:	Regulation 7	Materials and workmanship
Comment:		The system is acceptable. See section 11 and the <i>Installation</i> part of this Certificate.



The Building (Scotland) Regulations 2004 (as amended)

For new construction and a 'Conversion' of an existing building, as defined in Regulation 4

Regulation:	8(1)	Fitness and durability of materials and workmanship
Comment:		The system is acceptable. See section 11 and the <i>Installation</i> part of this Certificate.
Regulation:	9	Building standards – construction
Standard:	3.3	Flooding and ground water
Comment:		The system can contribute to minimising or eliminating the effects of flooding on the building fabric and/or the building element, with reference to clause 3.3.1 ⁽¹⁾⁽²⁾ . See section 5.1 of this Certificate.
Standard:	3.4	Moisture from the ground
Comment:		The system adequately resists the passage of moisture, with reference to clauses 3.4.1 ⁽¹⁾⁽²⁾ , 3.4.2 ⁽¹⁾⁽²⁾ , 3.4.5 ⁽¹⁾⁽²⁾ , 3.4.6 ⁽¹⁾⁽²⁾ and 3.4.7 ⁽¹⁾⁽²⁾ . See section 5.1 of this Certificate.
Standard:	3.6(a)	Surface water drainage
Comment:		The system can contribute to satisfying this Standard, with reference to clause 3.6.3 ⁽¹⁾⁽²⁾ . See section 5.1 of this Certificate.
Standard:	3.10	Precipitation
Comment:		The system adequately resists the passage of moisture, with reference to clause 3.10.1 ⁽¹⁾⁽²⁾ . See section 5.1 of this Certificate.
Regulation:	12	Building standards – conversions
Comment:		All comments given for this system under Regulation 9, also apply to this Regulation, with reference to clause 0.12.1 ⁽¹⁾⁽²⁾ and Schedule 6 ⁽¹⁾⁽²⁾ . (1) Technical Handbook (Domestic). (2) Technical Handbook (Non-Domestic).



The Building Regulations (Northern Ireland) 2000 (as amended)

For new construction and a 'Material Change of Use' of an existing building, as defined in Regulation A9

Regulation:	B2	Fitness of materials and workmanship
Comment:		The system is acceptable. See section 11 and the <i>Installation</i> part of this Certificate.
Regulation:	C4(a)(b)	Resistance to ground moisture and weather
Comment:		The system adequately resists the passage of moisture. See section 5.1 of this Certificate.

Construction (Design and Management) Regulations 2007

Construction (Design and Management) Regulations (Northern Ireland) 2007

Information in this Certificate may assist the client, CDM co-ordinator, designer and contractors to address their obligations under these Regulations.

See section: 1 *Description* (1.2) of this Certificate.

Non-regulatory Information

NHBC Standards 2008

NHBC accepts the use of Delta-FM, when installed and used in accordance with this Certificate, in relation to *NHBC Standards, Chapter 5.1 Substructure and ground bearing floors* and *5.2 Suspended ground floors*.

1 Description

1.1 Delta-FM membrane is a yellow, high-density polyethylene (HDPE) sheet with moulded studs, for use as a damp-proofing membrane. The membrane is available in the following dimensions:

Thickness (mm)	0.6
Stud height (mm)	3
Weight per unit area ($\text{kg}\cdot\text{m}^{-2}$)	0.6
Roll length (m)	20
Roll width (m)	2.0
Weight per roll (kg)	24
Air gap volume ($\text{l}\cdot\text{m}^{-2}$)	2.1

1.2 The membrane is formed in a continuous process in which HDPE is extruded into sheets and the studs impression formed.

1.3 Quality control is exercised over raw materials, during manufacture and on the final product.

1.4 Ancillary items used with the membrane include:

- Delta Qwik-Seal Plug — a plastic plug supplied with preformed rubber seal for use in masonry walls and concrete (see Figure 1)
- Delta Plug — glass-filled nylon plug for use in masonry walls and concrete (see Figure 2)
- Delta Tape — black butyl tape for sealing joints in the membrane
- Delta Rope — black butyl beading for sealing the membrane around pipes and openings, joining floor and wall membranes, and to seal around the head of the Delta Plugs prior to fixing the membrane
- Delta Mastic — an acrylic sealant for sealing the membrane around pipes and openings
- Delta Corner Strip — a self-adhesive membrane strip for sealing junctions between walls and floors, and for sealing joints at corners
- Delta Primer — a solvent-based primer for sealing porous substrates prior to application of the Delta range of butyl-based sealing products.

Figure 1 Delta Qwik-Seal Plug fixing detail

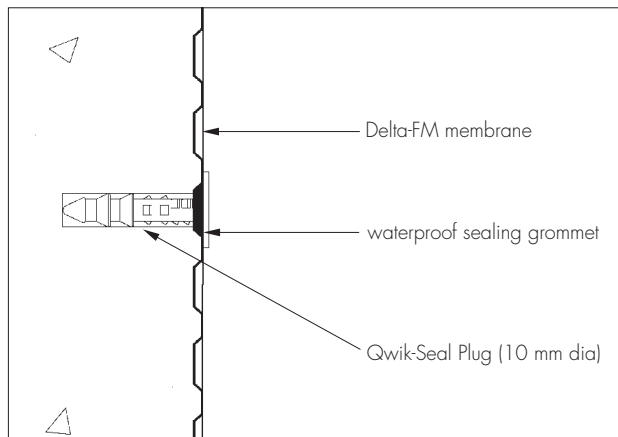
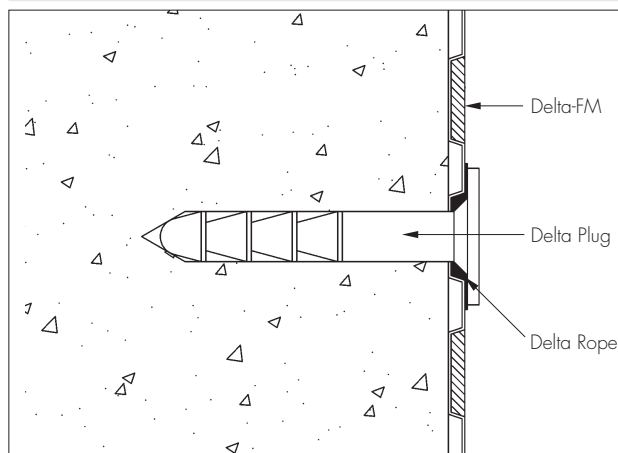

Figure 2 Delta Plug fixing detail



2 Delivery and site handling

2.1 The membrane is delivered to site in rolls secured with outer wrapping, and a headband bearing the product and manufacturer's name.

2.2 Rolls should be stored on end, under cover and protected from sharp objects, sunlight and high temperatures.

2.3 The packaging details of the ancillary items are shown in Table 1.

Item	Dimensions/volume	Packaging/quantity
Delta Qwik-Seal Plug	10 mm diameter 58 mm long	Boxes of 100
Delta Plug	11 mm diameter 70 mm long	boxes of 100 or 1000
Delta Tape	22.5 m long 28 mm wide 2 mm thick	1 roll per box 10 rolls per outer box
Delta Rope	4.75 m long 10 mm diameter	1 roll per box 10 rolls per outer box
Delta Mastic	0.4 litre cartridge	24 cartridges per box
Delta Corner Strip	20 m long 150 mm wide	Single rolls 4 rolls per box
Delta Primer	5 litre	Single 5 litre tin

2.4 Delta Primer is classified as 'harmful' and 'flammable' under *The Chemicals (Hazard Information and Packaging for Supply) Regulations 2009* (CHIP4) and should be stored in a cool place away from naked flames.

Assessment and Technical Investigations

The following is a summary of the assessment and technical investigations carried out on Delta-FM.

Design Considerations

3 Use

3.1 Delta-FM is used as damp-proofing on walls, floors and vaulted ceilings, above and below ground, in new construction or in existing buildings over a contaminated or damp background. It can support a dry lining, screed or flooring, in the following situations:

- on damp walls and floors in underground situations subject to high groundwater levels, and perennial moisture
- on vaulted ceilings of archways or cellars subject to water ingress
- in conjunction with a remedial dpc system where the walls and floors have a high salt content, and/or it is necessary to complete the installation immediately without allowing a period for initial drying
- over walls and floors which have a friable or painted surface, are contaminated (eg with oil or mould), or have a high salt content
- as a waterproofing membrane in areas subject to vibration.

3.2 Depending on the application required and the site conditions, the membrane may be used as:

- an underfloor damp-proof membrane
- a dry lining for walls, ventilated into the room via aeration slots at the top and bottom of the wall or via passive air vents, where access through an external wall is available
- a sealed system covering wall, floor and ceiling with provision made for disposing of water build-up behind the membrane via a sump and pump.

3.3 The membrane has not been assessed for use in chemically contaminated areas, such as brownfield sites.

3.4 The membrane consists of 0.6 mm thick HDPE and, in the opinion of the BBA, meets the requirement for a radon barrier according to BRE Report (BR 211 : 1999) *Radon : guidance on protective measures for new dwellings*. However, the effectiveness of the joint sealing system used with Delta-FM has not been assessed against radon by the BBA and is outside the scope of this Certificate.

3.5 The system is satisfactory for use in Type C (drained protection) constructions in accordance with BS 8102 : 2009.

3.6 Under normal operating conditions, the membrane is not affected by underfloor heating.

4 Practicability of installation

The membrane should only be installed by installers who have been trained and approved by the Certificate holder, or by competent specialist contractors.

5 Resistance to water and water vapour



5.1 The membrane is water resistant and has a high resistance to water vapour transmission. However, the system as installed is not resistant to hydrostatic pressure and, consequently, the measures described in the *Installation* part of this Certificate must be followed to ensure that the membrane acts as a drainage layer with no excessive build-up of water behind the system.

5.2 All joints and fixings must be sealed with Delta sealing products, and drainage channels and gullies, or sumps and pumps should be installed as necessary to disperse excess or standing water.

6 Risk of condensation

6.1 As with any room, there is a need to control the generation and dispersal of moisture in the internal environment and to select appropriate and robust designs to minimise the risk of both surface and interstitial condensation, especially where insulation is used over the membrane.

6.2 In common with most waterproofing membranes, the product has a very high resistance to vapour diffusion, and when placed on the cold side of a construction may increase the risk of interstitial condensation. A calculation should be carried out to BS 5250 : 2002 and designers should consider appropriate techniques for managing the safe egress of moisture vapour with care (such as control of the internal room environment or use of a vapour control layer on the warm side of the insulation), and in particular the effect of moisture on any materials at or in contact with materials below the local dew-point.

7 Resistance to salt transfer

The membrane provides an effective barrier to the transmission of salts or other contaminants from the substrate.

8 Resistance to puncture, impact and loading

8.1 The membrane has a high resistance to puncture and will not be damaged by normal foot traffic during installation or while laying concrete or screeding to BS 8204-1 : 2003.

8.2 The membrane can support the long-term imposed loadings defined in NA to BS EN 1991-1-1 : 2002, Table NA.2, categories A to D, without undue deformation.

9 Wall-mounted fittings

Wall-mounted fittings (apart from lightweight items such as framed pictures) should be fixed where possible into battens, whose position and number of support fixings into the loadbearing structure are predetermined. Only in exceptional circumstances should fittings be fixed (using proprietary fixings) through the membrane and lining board to the loadbearing structure behind. Holes made in the membrane must be repaired in accordance with the Certificate holder's approved procedures.

10 Maintenance

10.1 As the membrane is confined within a wall or floor space and has suitable durability (see section 11), maintenance is not required.

10.2 Regular maintenance of all gullies, sumps and pumps must be conducted to ensure that a build-up of water does not occur behind the membrane.

11 Durability



Under normal conditions of use the system will provide an effective barrier to the transmission of salts, liquid water and water vapour for the life of the structure in which it is incorporated.

Installation

12 Survey

12.1 Where the property is below ground, or where conditions are damp, a full survey is necessary by a specialist waterproofing surveyor to diagnose the cause and to establish if treatment is required.

12.2 If rising damp to above-ground elevations is found, a remedial treatment is conducted in accordance with the relevant Agreement Certificate, BS 6576 : 2005 and the Property Care Association *Code of Practice for Installation of Remedial Damp-proof Courses in Masonry Walls*, 2006.

12.3 Appropriate remedial measures are taken to rectify major causes of damp conditions or water ingress, and to repair structural defects.

13 Surface preparation

13.1 When used in new constructions, the concrete base must be laid in accordance with BS 8204-1 : 2003.

13.2 If a board covering is to be laid directly on the membrane, the concrete base must have a surface regularity with a maximum permissible departure of 5 mm from the underside of a 2 m straight edge, resting in contact with the floor, in accordance with BS 8204-1 : 2003.

13.3 When used in existing buildings any unsound plaster, render or screed is removed to expose the substrate and cleaned with a stiff brush to remove loose material, laitance, salt residue, mould or adhesive. If mould is present the substrate is treated with a fungicidal wash.

13.4 Uneven floor substrates should be dubbed out with a cement-sand (1:4) or cement-lime-sand (1:1:6) render or screed, to the tolerance described in section 13.2. They should be allowed to dry thoroughly before the Delta-FM membrane is installed above.

14 Procedure

General

14.1 Delta-FM may be used in combination with any of the appropriate Delta membranes which are the subject of other Product Sheets of this Certificate.

14.2 The membrane should be used with the flanged edge positioned in front of and overlapping the previously installed membrane width. Joints with the flanged edge are sealed using Delta Tape, while stud-to-stud joints (without the flanged edge) are sealed by overlapping the membrane by a minimum of three studs and positioning Delta Rope between the last two rows of studs or over-sealing the joint with Delta Corner Strip.

14.3 Fixings are made through the membrane into 10 mm holes, drilled centrally through the studs. Delta Qwik-Seal Plugs (complete with preformed rubber seal) are inserted into the holes and hammered flush with the membrane with a club hammer. The seal must be compressed to function as a barrier against water ingress, and this should be visually checked as each plug is fixed.

14.4 Alternatively, fixings are made through 11 mm holes, drilled centrally through the studs. Delta Plugs, to which Delta Rope has been applied around the rim, are inserted into the holes and hammered flush with the membrane. The Delta Rope forms a sealing gasket between the plug and the membrane.

14.5 On walls and ceilings, preservative-treated timber battens of minimum dimensions 25 mm by 38 mm are fixed into the Delta Plug's fixing hole using No 12 screws, or Delta Qwik-Seal Plug's fixing hole using No 10 screws, with a maximum screwing-in depth of 30 mm. The membrane can also be dry-lined, using free-standing framework, blockwork or similar. Where necessary, these should be tied back by fixing into the Delta Plug, or the Delta Qwik-Seal Plug.

Walls

14.6 Installation of the membrane is usually commenced at the top of the construction. The membrane may require initial fixing on a ceiling or along the upper edge of a wall, prior to final fixings along batten runs. For joints where the flanged edge is not used, the two membrane sheets are overlapped by a minimum of 100 mm, and for horizontal joints the lower sheet is always positioned in front of the upper sheet.

14.7 Spacing between fixings will depend on the method of dry lining to be applied. When using preservative-treated timber battens the fixings should be spaced at 600 mm centres. Proprietary metal fast track systems and independent frame systems will require less fixings, but sufficient should be used to ensure that the membrane is reasonably tight to the wall, especially at corners.

14.8 The installation is conducted over windows and the membrane is cut away to expose them. The gaps are then sealed with Delta Tape or Rope.

14.9 For doors and some obstructions the technique covered in section 14.8 cannot be used. Instead, the membrane is installed up to the perimeter and the gap sealed in the same manner.

14.10 Power cables, points and light switches preferably should be remounted in front of the membrane.

14.11 In below-ground installations, the practice of leaving the top of the wall membrane unsealed where there is no requirement for a ceiling membrane to be installed may need to be reconsidered in cases where ingress of gases, odours, or vermin is a consideration (such as in proximity to food preparation areas). The advice of the Certificate holder should be sought in these situations.

14.12 In above-ground installations the build up of water vapour behind the membrane is controlled by ventilating into the room via ventilation gaps provided at the ceiling and skirting board levels or via passive air vents, where access through an external wall is available.

Ceilings

14.13 Ceilings to be covered must always have a fall, as per vaulted cellar constructions, to ensure water does not lie against the membrane or a joint. Membrane sheets should have an overlap of 200 mm.

14.14 Delta Qwik-Seal Plugs, or Delta Plugs sealed with butyl rope should be used to fix the membrane to vaulted ceilings. Any sagging of the membrane between fixing points on ceilings should not be great enough for ponding to occur.

14.15 At the end walls of vaulted constructions the membrane must be turned down onto the end wall by a minimum 200 mm. The membrane is mitred as necessary to fit the curve of the ceiling, and the joints sealed with Delta Tape, Delta Rope or Delta Corner Strip. The wall membrane should be cut into the curve of the ceiling, fixed in front of the ceiling membrane, and the gap sealed with Delta Rope.

Floors

14.16 Floors should have a drainage outlet point. There should be a fall towards the outlet point or a drainage channel made around the circumference of the floor, to ensure that water can flow to the outlet.

14.17 The membrane is rolled out 'studs down' over the floor, and consecutive membrane widths are laid so the flanged edge overlaps the first sheet by three studs, and the joints sealed with Delta Tape. Stud to stud joints can be over-sealed using Delta Corner Strip in accordance with section 14.2.

14.18 The membrane is cut within 5 mm of any pipes and services in the floor, and the gap filled with Delta Rope. If necessary, a patch of membrane is overlaid and sealed to the services with Delta Rope, and its perimeter sealed with Delta Tape.

14.19 Fixings must not be applied through the floor membrane.

14.20 Where appropriate, at wall/floor junctions and corners of the installation, the membrane may be cut flush and the gap between the wall and floor membranes sealed with Delta Corner Strip. Alternatively, the floor membrane may be turned up by 100 mm at the wall.

14.21 Where internal or external corners occur, these should be oversealed using Delta Corner Strip, in accordance with the Certificate holder's installation instructions.

15 Dry lining of walls

Gypsum plasterboard to BS EN 520 : 2004, or similar dry lining boards which are the subject of a current BBA Certificate, are fixed to the battens with galvanized screws or nails, positioned a minimum of 12 mm from the edge of the board. Care should be taken to ensure that penetration of the plasterboard screws or nails is less than batten depth to avoid puncturing the membrane.

16 Floor membrane coverings

16.1 If required, extruded closed-cell polystyrene insulation boards, minimum density 30 kg·m⁻³, may be laid over the membrane.

16.2 Suitable tongue-and-groove flooring board panels, should be selected in accordance with BS EN 12871 : 2010, and loose-laid over the membrane to within 10 mm of the walls. The panels are staggered and the joints sealed with a thermoplastic wood adhesive to BS EN 204 : 2001.

16.3 Alternatively, the membrane is covered by concrete or screed a minimum of 50 mm thick (or a minimum of 65 mm thick if laid over insulation boards) in accordance with BS 8204-1 : 2003. Care should be taken to ensure the membrane is not displaced when placing the concrete or screed. The concrete screed should be reinforced to inhibit shrinkage cracks.

16.4 Proprietary screeds may also be considered, which can generally be laid at thicknesses less than 50 mm, but the use of these products with the membrane has not been assessed by the BBA and is outside the scope of this Certificate.

17 Finishing works

After the system has been installed and the walls dry-lined, permanent decorations such as vinyl paper or oil paint, may be applied. Temporary permeable decorations (necessary with traditional, cement-based waterproofers) are not necessary with this system.

Technical Investigations

18 Tests

Tests were carried out to determine:

- thickness
- resistance to nail tear
- resistance to long-term loading
- resistance to short term compression.

19 Investigations

19.1 A user survey of treated installations and contractors was conducted to establish the system's performance in use.

19.2 An assessment was made of the effectiveness of the sealing system based on data obtained during the assessment of Delta-MS500 membrane.

19.3 An assessment was made of the scope of use and durability of the system in relation to the generic properties of the membrane.

19.4 The manufacturing process and quality control procedures were examined and details were obtained of the quality and composition of the materials used.

Bibliography

BS 5250 : 2002 *Code of practice for control of condensation in buildings*

BS 6576 : 2005 *Code of practice for diagnosis of rising damp in walls of buildings and installation of chemical damp-proof courses*

BS 8102 : 2009 *Code of practice for protection of below ground structures against water from the ground*

BS 8204-1 : 2003 *Screeds, bases and in-situ floorings — Concrete bases and cement sand levelling screeds to receive floorings — Code of practice*

BS EN 204 : 2001 *Classification of thermoplastic wood adhesives for non-structural applications*

BS EN 520 : 2004 *Gypsum plasterboards — Definitions, requirements and test methods*

BS EN 1991-1-1 : 2002 *Eurocode 1 : Actions on structures — General actions— Densities, self-weight, imposed loads for buildings*

NA to BS EN 1991-1-1 : 2002 *UK National Annex to Eurocode 1 : Actions on structures — General actions— Densities, self-weight, imposed loads for buildings*

BS EN 12871 : 2010 *Wood-based panels — Performance specifications and requirements for load bearing boards for use in floors, walls and roofs*

Property Care Association COPO2 Code of Practice for Installation of Remedial Damp-proof Courses in Masonry Walls

Conditions of Certification

20 Conditions

20.1 This Certificate:

- relates only to the product/system that is named and described on the front page
- is granted only to the company, firm or person named on the front page — no other company, firm or person may hold or claim any entitlement to this Certificate
- is valid only within the UK
- has to be read, considered and used as a whole document — it may be misleading and will be incomplete to be selective
- is copyright of the BBA
- is subject to English law.

20.2 Publications and documents referred to in this Certificate are those that the BBA deems to be relevant at the date of issue or re-issue of this Certificate and include any: Act of Parliament; Statutory Instrument; Directive; Regulation; British, European or International Standard; Code of Practice; manufacturers' instructions; or any other publication or document similar or related to the aforementioned.

20.3 This Certificate will remain valid for an unlimited period provided that the product/system and the manufacture and/or fabrication including all related and relevant processes thereof:

- are maintained at or above the levels which have been assessed and found to be satisfactory by the BBA
- continue to be checked as and when deemed appropriate by the BBA under arrangements that it will determine
- are reviewed by the BBA as and when it considers appropriate.

20.4 In granting this Certificate, the BBA is not responsible for:

- the presence or absence of any patent, intellectual property or similar rights subsisting in the product/system or any other product/system
- the right of the Certificate holder to manufacture, supply, install, maintain or market the product/system
- individual installations of the product/system, including the nature, design, methods and workmanship of or related to the installation
- the actual works in which the product/system is installed, used and maintained, including the nature, design, methods and workmanship of such works.

20.5 Any information relating to the manufacture, supply, installation, use and maintenance of this product/system which is contained or referred to in this Certificate is the minimum required to be met when the product/system is manufactured, supplied, installed, used and maintained. It does not purport in any way to restate the requirements of the Health & Safety at Work etc Act 1974, or of any other statutory, common law or other duty which may exist at the date of this Certificate; nor is conformity with such information to be taken as satisfying the requirements of the 1974 Act or of any statutory, common law or other duty of care. In granting this Certificate, the BBA does not accept responsibility to any person or body for any loss or damage, including personal injury, arising as a direct or indirect result of the manufacture, supply, installation, use and maintenance of this product/system.